

Renewable Energy Assessment



WAIKATO REGION

- Final C
- 26 July 2006



Renewable Energy Assessment

WAIKATO REGION

- Final C
- 26 July 2006

Sinclair Knight Merz
25 Teed Street
PO Box 9806
Newmarket, Auckland New Zealand
Tel: +64 9 913 8900
Fax: +64 9 913 8901
Web: www.skmconsulting.com

COPYRIGHT: The concepts and information contained in this document are the property of Sinclair Knight Merz Limited. Use or copying of this document in whole or in part without the written permission of Sinclair Knight Merz constitutes an infringement of copyright.

LIMITATION: This report has been prepared on behalf of and for the exclusive use of Sinclair Knight Merz Limited's Client, and is subject to and issued in connection with the provisions of the agreement between Sinclair Knight Merz and its Client. Sinclair Knight Merz accepts no liability or responsibility whatsoever for or in respect of any use of or reliance upon this report by any third party.



Executive Summary

This study aims to identify and assess the renewable energy potential in the Waikato region and assist Environment Waikato (EW) to identify where it can play a role in realising that potential using both regulatory and non-regulatory approaches.

The uptake of renewable energy is constrained by a wide range of barriers that not only includes the technical challenges and costs of developing such resources, but also the cultural and environmental concerns surrounding the use of natural resources.

Most renewable energy projects have relatively high capital costs for plant and a revenue stream that is linked to the often periodic or intermittent nature of some renewable sources. The potential effects on areas of high cultural, ecological and landscape value mean that there are limitations as to where renewable projects may be acceptable. Most projects attract opposition from some sectors and face long consenting and development times.

At the same time, greater uptake of renewable energy presents national benefits such as enhanced security of supply and reduced climate change effects. In addition, greater uptake of renewable energy would allow regions, districts and cities to address issues such as: high liquid fuel and electricity costs that could contribute to a significant economic downturn; transmission / distribution constraints leading to supply disruptions and loss of economic activity; uncertainties associated with other conventional energy sources such as gas reserves and coal fired power plants which may lead to local supply shortfalls; and the economic opportunities presented by the application of mature, cost effective renewable energy technologies in the short-term and the development / commercialisation of emerging technologies in the medium-term.

An initial assessment of the renewable energy development potential of the region is provided in this report. The estimates of renewable energy potential seek to identify major resources that are available and to provide an indication of their relative magnitude. It is to be noted that the assessment has not accounted for how environmental and cultural issues will affect renewable energy potential. Rather, the assessment presents indicative estimates for the amount of renewable energy that could be realised in terms of the resource available outside National Parks and Department of Conservation lands (as a working, first order definition of what projects may be environmentally acceptable) using technologies that are already economic or are likely to become economic over the course of the next ten years (i.e. the review period of Regional Policy Statements).



For the Waikato Region, this renewable potential comprises:

- Another 520 MWe of geothermal electricity generation, compared with existing capacity of about 380 MWe, plus a large potential for more direct use of geothermal heat.
- Approximately 500 MW of wind capacity, depending on the degree of acceptance of adverse effects.
- Remaining hydro potential of about 100 MW, in mini, small, and medium scale projects in areas outside the Department of Conservation land and Native Forest areas, compared to the existing installed capacity of almost 1400 MW.
- Wave energy in the thousand megawatt range, ignoring environmental constraints and conflicts with other maritime users.
- About 20 million litres of ethanol per year for transport fuel from grain crops currently grown in the region. About 200 million litres per year of ethanol or 800 GWh/year of electrical energy from woody biomass derived from low-grade forestry.
- Significant potential for solar thermal hot water systems, considerably less for solar photovoltaic.

Development of this renewable potential could be assisted by:

- Increasing the range of expertise within the council such that the council's capacity with regard to renewable energy is commensurate with that of its other functions, *e.g.* soil conservation or water quality.
- Developing an energy plan / strategy.
- Developing spatial representations of renewable energy resources overlaid with information relating to development constraints (*e.g.* outstanding landscapes, areas of high cultural value).
- Establishing a programme of energy forums involving selected councils from across New Zealand.
- Advocating the implementation of appropriate economic instruments at a national level.
- Working with energy generators, tangata whenua and other interested bodies to develop industry codes of practice for renewable energy production.

Regional Policy Statements

- Identifying in the Regional Policy Statement, areas within the region suitable for renewable energy development including wind, hydro, geothermal and marine based generation.



- Ensuring that the Regional Policy Statement includes a series of objectives and policies outlining how “trade offs” between localised effects and the benefits of renewable energy should be made.
- Amending the Regional Policy Statement to recognise the potential future renewable energy technologies and make high level policy provision for such
- Monitoring the state of technology development and making appropriate provision for emergent technologies by making changes to the Regional Policy Statement.

Regional Plans

- Ensuring that Regional Plans provide for existing renewable energy generation facilities.
- Amending Regional Plan rules to:
 - reduce consent thresholds for energy generation based on renewable resources
 - provide longer consent periods for renewable energy projects
 - provide greater air discharge thresholds for biomass energy generation where this is consistent with ambient air quality criteria
 - recognise the potential of and make high level policy provision for future renewable energy technologies

District Plans

- Ensuring that District Plans provide for existing renewable energy generation facilities.
- Working closely with the District Councils within the region to ensure that district plans reflect the renewable energy objectives and policies of the Regional Policy Statement.
- Amending District Plans to:
 - ensure that rules do not preclude renewable energy development in areas identified in the Regional Policy Statement (*e.g.* landscape protection areas should not include areas deemed suitable for wind power generation in the Regional Policy Statement).
 - give effect to the objectives and policies proposed above for the Regional Policy Statement
 - make appropriate provision for various scale energy generation facilities
 - allow small scale renewable energy production (*e.g.* solar and wind) as permitted activities
 - provide subdivision rules that encourage appropriate site orientation in order to support solar heating and power generation and reduce shading
 - ensure that rules do not unreasonably preclude domestic scale renewable energy production (*e.g.* allows solar panels on roofs) and protect solar access to nearby properties.



Contents

1.	Introduction	1
1.1	Background	1
1.2	Study Objectives	1
1.3	Report Structure	2
1.4	Data Sources and Quality	3
2.	Drivers	4
2.1	Introduction	4
2.2	Economic Growth	4
2.3	Current Energy Mix	5
2.4	Energy Costs	8
2.5	Security of Supply	10
2.6	Local Benefits	12
2.7	Climate Change	13
2.8	Resource Management Act	13
2.9	Barriers to Renewable Energy	15
2.10	Potential Role for Local Government	18
3.	Technologies	19
3.1	Technical and Economic Considerations	19
3.1.1	Wind power generation	19
3.1.2	Solar PV generation	20
3.1.3	Solar thermal conversion	20
3.1.4	Hydro generation	20
3.1.5	Geothermal power generation	21
3.1.6	Marine power generation	21
4.	Renewable Energy Potential	31
4.1	Introduction	31
4.2	Wind	31
4.2.1	Wind Resource	31
4.2.2	Potential Electricity Generation from Wind	32
4.3	Solar	35
4.3.1	Solar Resource in the Waikato Region	35
4.3.2	Potential for Solar Thermal	37
4.3.3	Potential for Solar Photovoltaic	37
4.3.4	Potential for Passive Solar Building Design	37
4.4	Hydro	38



4.4.1	Previous Hydropower Capacity Studies	38
4.4.2	Background	39
4.4.3	The Developed Hydropower Resource	40
4.4.4	The Market for Hydropower Development	41
4.4.5	Possible Future Hydropower Potential	41
4.4.6	Other Possible Hydropower Options	43
4.4.7	Summary	44
4.5	Biomass	45
4.5.1	Biomass Resource in Waikato Region	45
4.5.1.1	Agricultural Crops for Energy	45
4.5.1.2	Forestry and Wood Processing Residues	48
4.5.1.3	Short Rotation Woody Biomass for Energy	48
4.5.1.4	Livestock Farming – Dairy and Meat	48
4.5.1.5	Municipal Solid Waste	50
4.5.1.6	Sewage	51
4.5.2	Technology	51
4.5.2.1	Transport Biofuels	51
4.5.2.2	Electricity generation	54
4.5.3	Summary of Resource Potential	54
4.6	Geothermal	54
4.6.1	Power Generation	54
4.6.2	Direct Use	56
4.6.3	Summary of Resource Potential	62
4.7	Marine	62
4.7.1	Tidal Resource	62
4.7.2	Wave Resource	66
5.	Enabling Assistance	70
5.1	Introduction	70
5.2	Renewable Energy Expertise	70
5.3	Renewable Energy Plans / Strategies	70
5.4	Resource / Constraint Mapping	71
5.5	National Renewable Energy Forums	71
5.6	Economic Instruments	71
6.	Regulatory Approaches	73
6.1	Current Regulatory Approaches	73
6.2	Potential Regulatory Approaches	74
6.2.1	Identification of Suitable Renewable Energy Locations	74
6.2.2	Non-Locational Policy Development	76
6.2.3	Consents	76
6.2.4	Domestic or Small Scale Developments	77



6.2.5	District Plans	78
6.2.6	Future Proofing Policy Statements and Plans	79
7.	References	80
Appendix A	Previously Identified Hydro Schemes	82
Appendix B	Resource Maps	84



Document history and status

Revision	Date issued	Reviewed by	Approved by	Date approved	Revision type
Draft Final	17 May 2006	Phil White	Greg Ussher	17 May 2006	
Final	31 May 2006	Jim Lawless	Greg Ussher	31 May 2006	
Final B	22 June 2006	Phil White	Greg Ussher	22 June 2006	
Final C	24 July 2006	James Muir	James Muir	24 July 2006	Minor amendments to text and maps

Distribution of copies

Revision	Copy no	Quantity	Issued to
Draft Final	pdf	1	Selwyn Blackmore, EECA
Draft Final	pdf	1	Blair Dickie, Environment Waikato
Final	pdf and hard copy	1, 2	EECA
Final	pdf and hard copy	1, 2	EW
Final B	pdf and hard copy	1, 2	EECA
Final B	pdf and hard copy	1, 2	EW
Final C	pdf	1	Sharleen Hannon, Selwyn Blackmore, EECA
Final C	pdf	1	Blair Dickie, Environment Waikato

Printed:	27 July 2006
Last saved:	26 July 2006 09:15 AM
File name:	I:\APWR\Projects\AP01157\Deliverables\Waikato\Waikato Final C.doc
Author:	Phil White
Project manager:	Phil White
Name of organisation:	Energy Efficiency and Conservation Authority
Name of project:	Regional Renewable Energy Assessment
Name of document:	Waikato Regional Renewable Energy Assessment
Document version:	C
Project number:	AP01157



1. Introduction

1.1 Background

The growth in New Zealand's energy demand over the past three decades has mainly been met by non-renewable sources despite the widespread availability of potential renewable resources throughout the country.

Renewable energy resources face barriers to development that often include high capital costs, difficulty securing access to use natural resources and the practicalities of delivering the energy to where it is to be used. Consequently, the Government has developed energy strategies and made recent changes to the Resource Management Act (RMA) to encourage greater uptake of renewable energy, reduce climate change effects and increase security of energy supply.

While councils and territorial authorities play a significant role in the consenting process for any renewable energy development, this role has (with a few notable exceptions) largely been in reaction to applications. Under the recent changes to the RMA there is a greater requirement on Councils to provide for renewable energy, but as yet there is no coherent knowledge base on the nature of the resources themselves nor a precedent for policy development that meets the new requirements.

1.2 Study Objectives

The Energy Efficiency and Conservation Authority (EECA) has implemented a program of Renewable Energy Assessments to assist councils with their policy and plan reviews and their new infrastructure responsibilities for renewable energy under the RMA.

EECA appointed Kinclair Knight Merz (SKM) to undertake a study whose objectives were to identify, assess, report and advise on the:

- Renewable energy potential in each region.
- Councils' role in realising the potential.
- Council's regulatory approaches.
- Information to enhance councils' knowledge.

By providing reliable renewable energy resource information and analysis, these assessments will help direct accurate targeting of renewable energy development opportunities; raise the profile of renewable energy; and provide a sound underpinning of policy development and private investment in renewable energy.



This report is one of eight assessments prepared under this program.

In New Zealand there are a total of 85 councils. In addition to 53 district councils and 15 city councils, territorial authorities which fall under the control of 12 regional councils, there are 5 unitary authorities that lie outside the jurisdiction of a regional council and have responsibilities of both territorial and regional councils. After discussions led by EECA, six regional councils and two unitary authorities (Marlborough and Tasman) were included within the study:

- Environment Canterbury
- Environment Waikato
- Horizons Regional Council
- Marlborough District Council
- Northland Regional Council
- Taranaki Regional Council
- Tasman District Council
- Greater Wellington Regional Council

Throughout this report, 'council' is used as a collective term for regional councils and unitary authorities.

1.3 Report Structure

The remainder of this report is structured in the following manner:

- **Chapter 2 - Drivers** outlines the national-level drivers for renewable energy in terms of: policy, energy use, supply and pricing. This chapter also provides a summary of key barriers to greater uptake of renewable energy.
- **Chapter 3 - Technologies** presents a tabular summary of existing and emerging renewable energy technology options for New Zealand.
- **Chapter 4 - Local Potential** describes the region's renewable energy resource and provides a preliminary indication of the magnitude of the utilisable resource.
- **Chapter 5 - Enabling Assistance** provides suggestions for how the council could promote renewable energy using non-regulatory methods.
- **Chapter 6 - Regulatory Approaches** summarises the region's existing regulatory approach to renewable energy and outlines alternative approaches for consideration.



Reports have been prepared for each of the eight councils using the above structure. In addition, a summary report has been prepared for EECA.

1.4 Data Sources and Quality

This assessment of the renewable energy potential within the regions relies primarily on previously published, publicly available information and data. We have used recent summaries of renewable energy potential, but where possible also reverted to the original sources of data.

Some of these sources are contradictory or very non-specific. While some of the available data (such as the hydro power potential) is quite detailed and has been thoroughly reported, other data (such as the wind energy) are poorly defined by existing assessments and not reliable for identifying more than broad parts of the regions that may have high energy potential.

Commentary on the status of marine energy technologies and their costs has been provided by the New and Renewable Energy Centre (NaREC) in the UK which is an independent test facility and technology assessment specialist. NaREC also made first order assessments of tidal current energy from basic published flow data.

The timing and scope of this work has not allowed any extensive new independent assessment of natural resources, although we have re-evaluated some technical and cost criteria for defining resources within the earlier assessments based on our own recent resource evaluations for individual projects or made some preliminary estimates based on published primary information.

Where no energy assessment data has been published (such as tidal current energy) we have made preliminary estimates using suitable guidelines applied to primary data that may be available (such as current velocity in the case of tidal flows). Estimates of the portion of the resource that may practically be used have been made by determining whether any restrictions such as Conservation land may restrict access.

Overall, the resource assessments must be regarded as first order indications of the magnitude and location of each resource. Defining the location, magnitude and probable delivery cost for each type of resource, for each scale of development (from large scale grid-based power generation to micro applications) would be a substantial exercise but could be justified if this were to be the basis for specific designation-based planning approaches.

Existing policy and plan documents for the region have been examined and supplemented by discussions with council representatives.

Interviews have been conducted with TrustPower and Mighty River Power to gain their perspectives on the issues facing the development of renewable energy projects.



2. Drivers

2.1 Introduction

This chapter outlines the national-level drivers for renewable energy in terms of policy, energy use, supply and pricing. In addition, this chapter provides a summary of key barriers to greater uptake of renewable energy.

2.2 Economic Growth

In the majority of countries, there is a very strong link between economic growth and growth in energy supply. Over the years, there has been much discussion of decoupling these two factors in developed countries such that strong economic growth could be achieved whilst reducing total energy supply. Although the energy efficiency of some economies has improved, economic growth has been such that total energy supply has steadily increased.

In New Zealand, the long-term energy efficiency of the economy has improved (Figure 1)¹. This long term increase in energy efficiency has been brought about by GDP growth that has exceeded growth in total primary energy use (Figure 2). It is to be noted that the total primary energy supply figures are distorted to some degree by the geothermal component which includes a large portion of un-used heat energy.

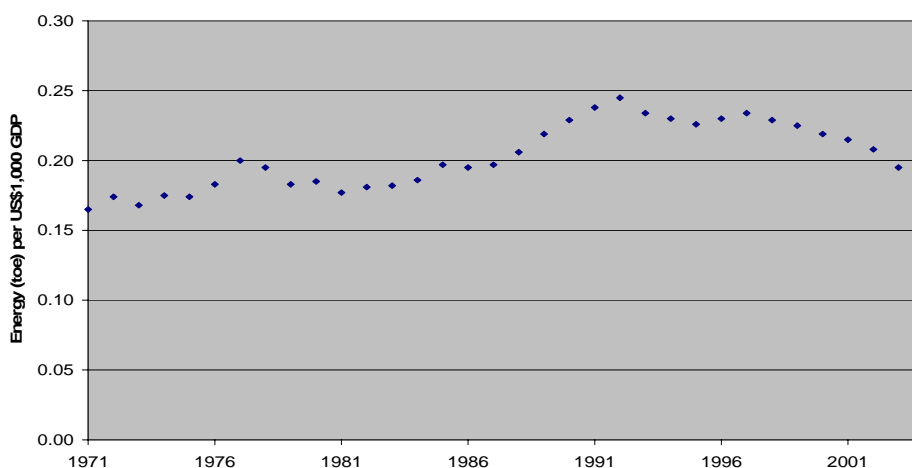

■ **Figure 1 Energy efficiency of the New Zealand economy 1971-2004 (OECD², 2006)**

¹ Tonnes of oil equivalent (toe) per thousand US dollars of GDP using Purchasing Power Parity (PPP).

² Organisation of Economic Cooperation and Development

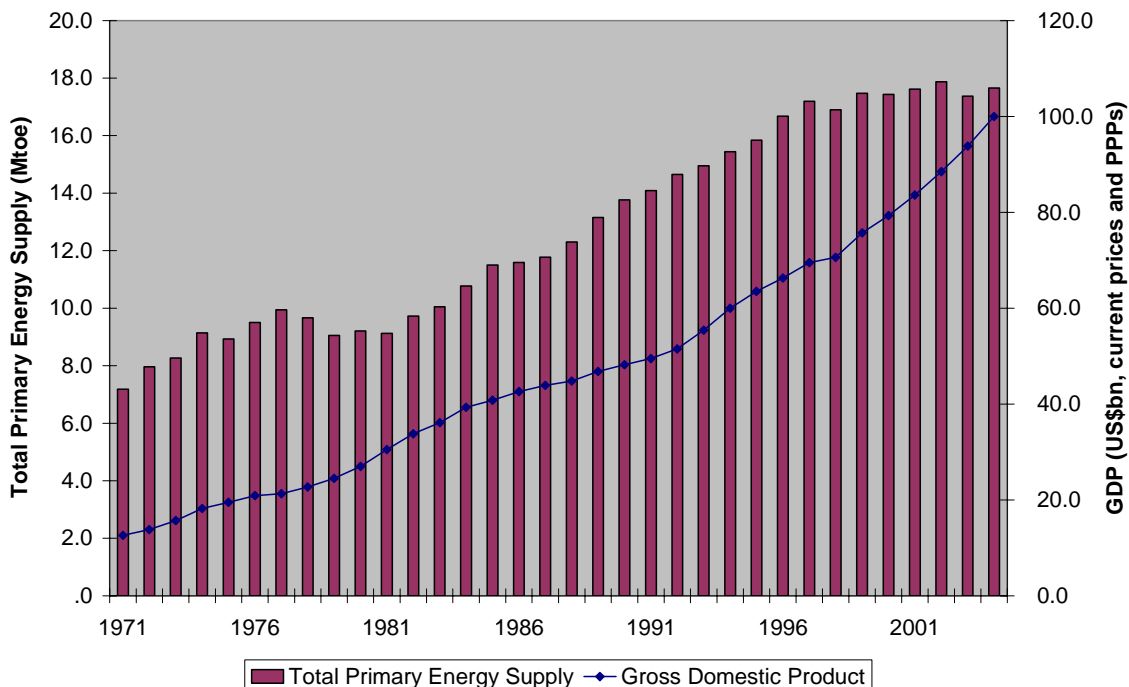

■ Figure 2 New Zealand economy and energy supply 1971-2004 (OECD, 2006)

2.3 Current Energy Mix

In 2004, about one third of New Zealand’s total primary energy supply was secured from renewable energy sources, one third from imported oil products and the remaining third from indigenous natural gas and a mix of local and imported coal (Figure 3). Of the energy finally used, 40% is for transportation and about 30% is delivered as electricity.

Waste heat used for co-generation of electricity has been reported as a renewable energy in the published energy data, however much of this is derived from coal fired heat (e.g. the Glenbrook Steel Mill) and so is not renewable. As noted above, the renewable energy resource data include all the geothermal heat extracted from the reservoir, making no allowance for the conversion efficiency to electricity. Hence the magnitude of New Zealand’s energy derived from renewable sources is effectively over-stated in the published data.

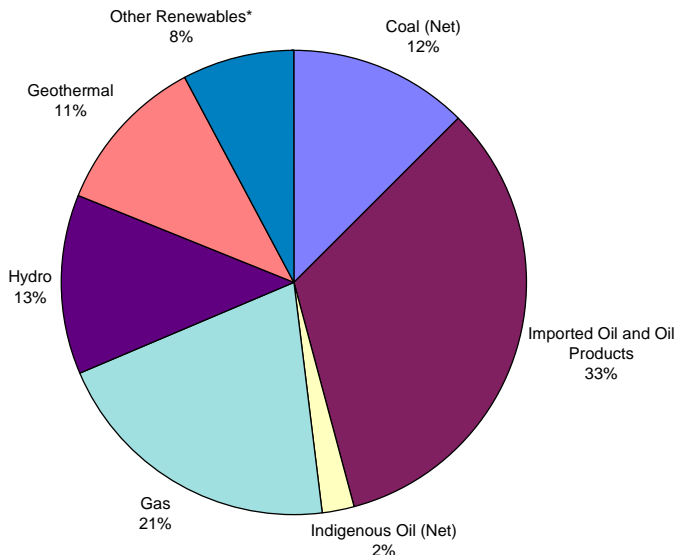

■ **Figure 3 New Zealand’s primary energy use by source, 2004. NB: Other Renewables* includes electricity generation from wind, biogas, industrial waste and wood, and solar water heating (MED³, 2006).**

Although there has been a growth in total renewable energy use since 1971 (Figure 4), the percentage of energy derived from renewable sources has fallen from 39% to 31% over the same period (Figure 5). The faster growth of non-renewable energy sources is driven largely by the transport sector.

³ Ministry of Economic Development

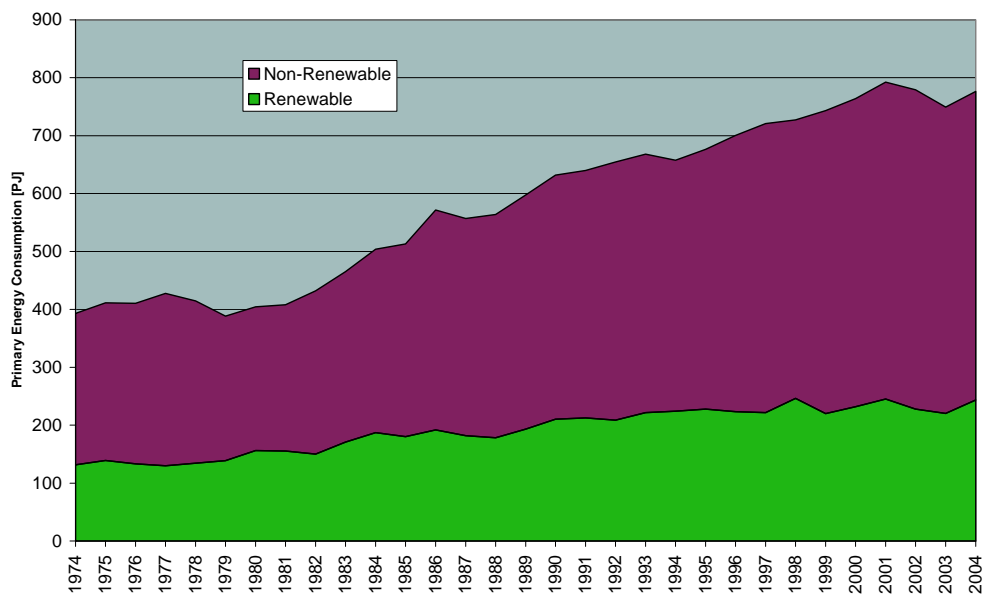

■ **Figure 4 New Zealand's primary energy usage 1974-2004 (MED, 2006)**

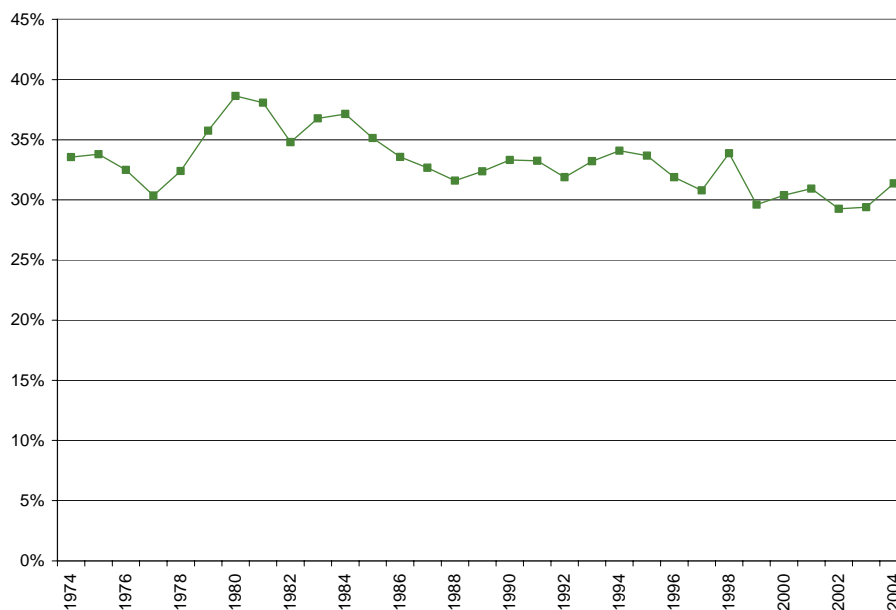

■ **Figure 5 New Zealand's primary energy supply from renewable sources 1974-2004 (MED, 2006)**

In summary, the majority of New Zealand's current energy supply comprises oil, gas and coal, a large proportion of which is imported. Furthermore, the current proportion of energy from renewable sources is near the thirty-year historic low. If the present situation is to be changed, there needs to be a very clear set of benefits for doing so in terms of energy costs, security of supply and climate change.



2.4 Energy Costs

The cost of liquid fuels has grown rapidly over recent years, with the price of basic imported petrol (excluding taxes) doubling since 2003 (Figure 6). This trend is very much greater than that predicted by the Ministry of Economic Development (MED) in its 2003 projections of future energy costs, where even under the high cost scenario, crude oil was predicted to be US\$30 / bbl by 2025. However, by 2006, the cost was over US\$70 / bbl. The rapid increase in oil prices is symptomatic of rising energy prices across the board as international demand for raw materials grow, market forces set the price for substitute materials and security of supply concerns continue (e.g. Deffeyes, 2001). Although increases in electricity prices have not been as substantial as those for liquid fuels, certain consumer groups, particularly residential consumers, have seen electricity prices (excluding GST) rise from 12.48c/kWh⁴ in 1995 to 16.59c/kWh in 2005, a 30% increase in real terms over ten years (Figure 7).

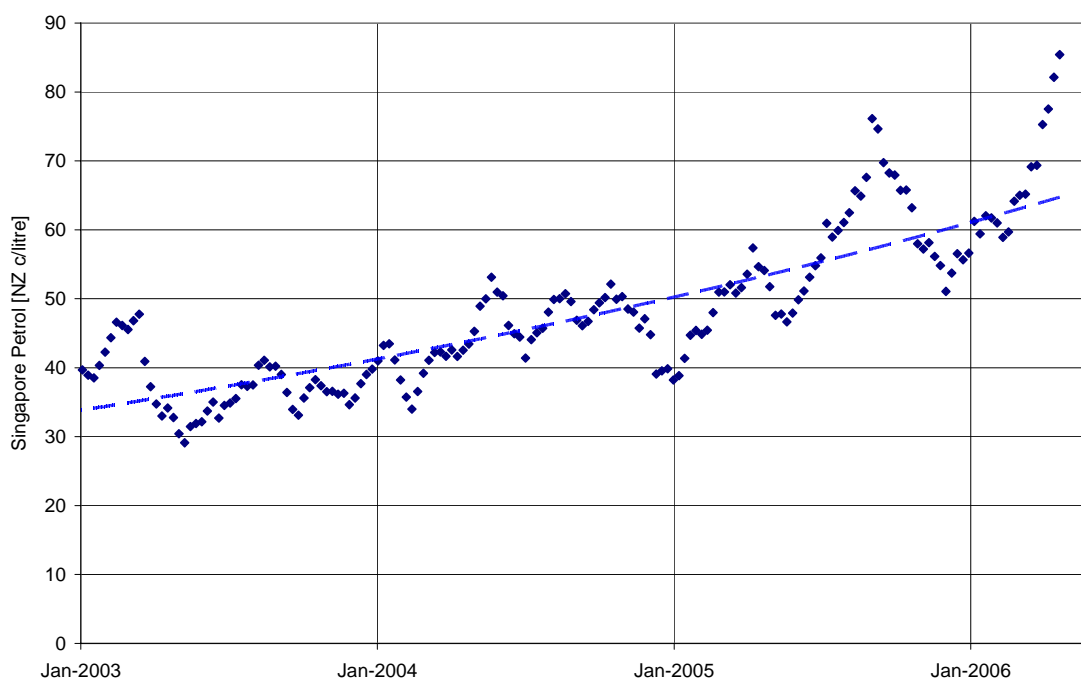

■ **Figure 6 Trends in the cost of imported liquid fuels in New Zealand. Cost of Singapore petroleum (NZ c/litre) (MED, 2006)**

⁴ kWh (kilowatt-hour) The standard unit of electricity supplied to the consumer. Equal to 1 kilowatt acting for 1 hour. Or 1 kWh = 3.60 x 10⁶ Joules

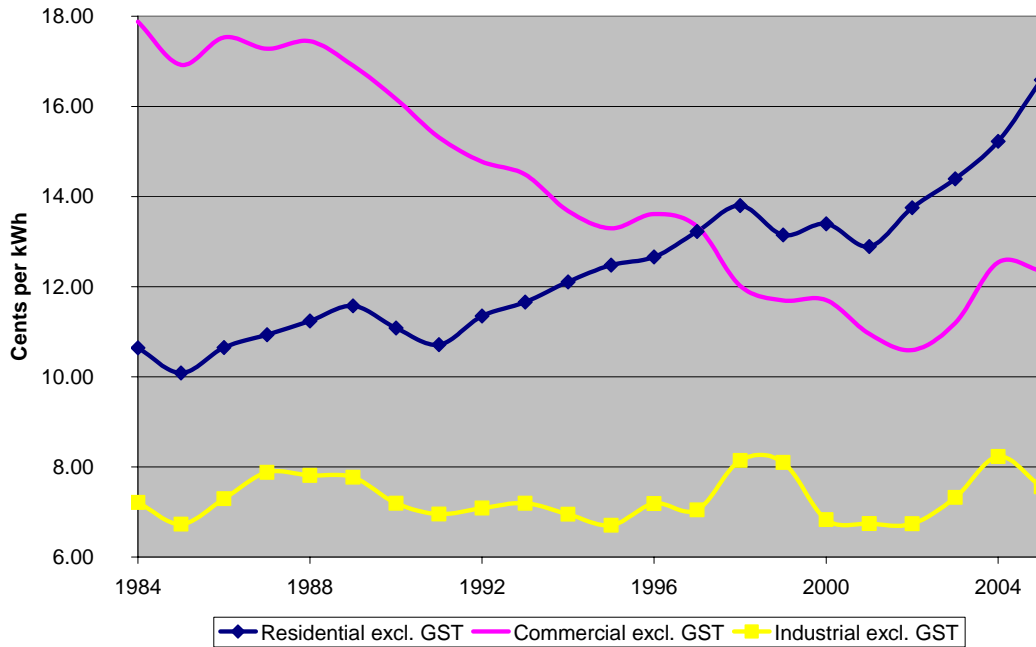

■ **Figure 7 Electricity consumers prices expressed 1984-2005 (Real year end March 2005 prices) (MED, 2006)**

The concern for New Zealand and other developed countries is that rising energy costs may lead to a decrease in energy demand and this, combined with already high labour costs, will reduce economic competitiveness and soften economic growth.

However, one of the key barriers to greater uptake of renewable energy has been cost, particularly upfront capital costs for electricity, which have typically been higher than comparable costs for fossil fuels. However, this situation changes as international prices for oil, coal and gas continue to increase.

Increasing electricity costs will mean that more renewable projects should be economically feasible as the market price of electricity exceeds their cost of generation (see for example Figure 8 from MED’s Energy Outlook to 2025 published in 2003). That MED prediction indicated that renewable energy could in fact dominate the new generation market given suitable market electricity prices.

Similarly, it is expected that biofuels will increasingly become mainstream if high oil prices are sustained.

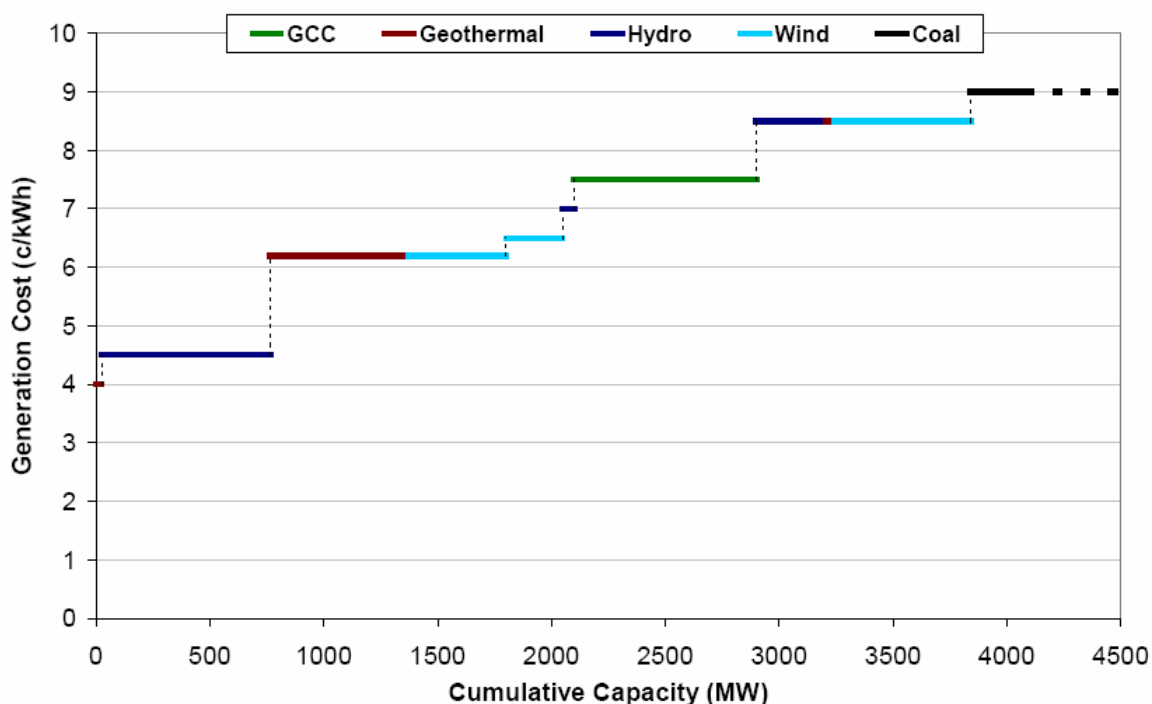

■ **Figure 8 Indicative quantities of new generation sources viable at a range of prices (MED 2003) NB: GCC stands for Gas Combined Cycle**

2.5 Security of Supply

A diversified portfolio of renewable energy supply can improve the resilience of the New Zealand economy to future energy supply problems and price shocks. This is recognised as one of the main goals of the National Energy Efficiency and Conservation Strategy (NEECS).

In general, energy sources present some form of risk, including:

- Continuity of supply, either through exposure to international markets or limited indigenous energy reserves
- Limitations for future growth
- Exposure to international price increases

These are detailed in Table 1 for New Zealand’s energy sources.



■ **Table 1 Supply risks to New Zealand’s energy sources**

Energy Source	Risk
Natural gas	<p>Limited life of Maui field, some new discoveries have been made but there are not currently sufficient to replace Maui and confidently enable major expansion of longer term gas usage.</p> <p>Imported Liquefied Natural Gas (LNG) or Compressed Natural Gas (CNG) is a possible supplement or replacement for indigenous gas reserves. It requires additional infrastructure and presents full exposure to international pricing and supply.</p>
Coal	<p>Supplies of low-sulphur, low-ash coal are presently sourced internationally. This has exposure to international pricing and supply.</p> <p>New Zealand has large reserves of lower grade coal that could form a longer term energy supply if and when barriers to its extraction and use are resolved.</p>
Oil and petroleum liquid fuels	<p>There is limited indigenous production of liquid fuels. Over 80% of liquid fuels are imported, presenting exposure to international pricing and supply.</p>
Hydro	<p>New Zealand’s relatively low lake storage volumes mean that available water flows are strongly affected by weather variation. In addition, hydropower’s long term generating capacity could be affected by climate change.</p> <p>New hydropower generation projects have been identified for a number of years and several have recently been progressed. However, these projects have faced major barriers in securing water use consents.</p> <p>Resource consents have no automatic right of renewal and are periodically exposed to public review and objection.</p>
Geothermal	<p>Not exposed to climate change. Resources will change under extraction and require some on-going investment to maintain production. Cost of capital for new developments is linked to international commodity prices (steel, generation plant).</p> <p>Barriers to securing resource consents for new projects.</p> <p>Resource consents have no automatic right of renewal and are periodically exposed to public review and objection. Concern over subsidence has affected one consent renewal.</p>
Wind	<p>Some exposure to climate change.</p> <p>Major barriers to securing resource consents for new projects.</p> <p>Resource consents have no automatic right of renewal and are periodically exposed to public review and objection.</p>

Diversification into a wider range of indigenous renewable energy sources could help mitigate these risks in two ways: reducing dependence on international fuel markets; and reducing dependence on a single form of indigenous renewable resource (*i.e.* hydropower). On the latter issue, since encountering several very “dry” years with consequent low levels of electricity reserve (1992, 2001, 2003) and with little new generation capacity being added to the New Zealand system, the government and major generation companies have recognised the need for additional diversified electricity generation. The generation companies have been making substantial effort to



develop new power generation from hydro, wind, geothermal, gas and coal but this has had limited success. Section 2.9 highlights the key barriers for renewable energy.

2.6 Local Benefits

The NEECS recognises the potential benefits for regional economic development that can arise from the development of renewable energy projects. Renewable energy projects (with the exception of biomass plant, where location is an economic consideration) need to be located close to the natural resources upon which they depend and this is usually away from the main urban centres. It is also recognised that for sources such as wind, there is value in having a good geographic spread of projects to increase the likelihood of having a well-balanced system. For the regions, this can mean increased economic activity associated with energy developments and the associated improved strength of local electrical network and supply. Biofuel resources require sustained agricultural activity to grow and harvest fuels, offering a long term and alternative form of economic activity. In addition, some renewable energy sources such as biofuels and geothermal can have secondary benefits in terms of direct heat use for agriculture or industrial processes, and some hydro projects can enable agricultural irrigation schemes.

During the course of the project, a number of councils highlighted pressing energy-related issues in their region, which could be at least partially addressed by a greater uptake of renewable energy.

- Transmission / distribution constraints leading to supply disruptions and associated loss of economic activity or the potential for supply disruption which could limit future growth and inward investment.
- Uncertainties surrounding the future of local energy sources (*e.g.* gas reserves) or local large-scale power generation plants (*e.g.* coal-fired units) which may lead to a supply shortfall, particularly in combination with distribution constraints.
- Liquid fuel and electricity costs which have the potential to cause a serious economic downturn, particularly in those regions where the local economy is largely dependent on agriculture, forestry and other sectors which are large consumers of liquid fuels.
- Regions where there is a substantial renewable resource, which can be used through the application of mature, cost effective technologies with environmental impacts that are broadly acceptable to the community.
- Regions where there is substantial renewable resource, which could be harnessed using emerging technologies over the next years and which have the desire to become regional, national or international technology leaders.
- Regions where there is considerable expertise of new energy technologies, which would benefit from the development of a regional market for their applications.



- A further factor to consider is that in 2013 lines companies will no longer be obligated under Regulation to continue supplies to (uneconomic) rural customers.

2.7 Climate Change

New Zealand has ratified the Kyoto Protocol, which entered into force on February 16, 2005. New Zealand's target is 100%, which means that New Zealand is required under the Protocol to reduce its greenhouse gas emissions back to 1990 levels on average during the First Commitment Period (CP1 or 2008-2012), or otherwise take responsibility for any excess emissions. It was envisaged that for New Zealand this target would be able to be met through a combination of domestic emissions reductions and increases in carbon sinks. It was also anticipated that more significant emission reductions would need to be negotiated for future commitment periods.

In May 2005, an estimate of New Zealand's CP1 emissions position relative to the target was projected to be about 32 million units (tonnes of carbon dioxide equivalent). In December 2005 the net emission deficit was increased to just below 51 million units, reflecting updated information about deforestation intentions. The decision to cancel the carbon tax is expected to increase the deficit to about 64 million units, although no account has been made of any replacement policies currently under consideration.

Renewable energy will significantly assist New Zealand to meet its obligations under the Kyoto Protocol whilst helping to meet New Zealand's growing electricity demand without increasing the use of thermal generation, whose greenhouse gas emissions contribute to climate change.

2.8 Resource Management Act

The Resource Management (Energy and Climate Change) Amendment Act 2004, introduced three new matters into section 7 (Other Matters) of Part II of the Resource Management Act 1991 (RMA), requiring all persons exercising functions and powers under the Act to have particular regard to:

- (ba) the efficiency of the end use of energy
- (i) the effects of climate change
- (j) the benefits to be derived from the use and development of renewable energy; and

To support the section 7(j) amendment, section 2 of the RMA was amended to define "renewable energy" as "energy produced from solar, wind, geothermal, hydro, biomass, tidal, wave, and ocean current sources".



The law relating to these matters has been refined to some extent by the Environment Court in its decision on *Genesis Power Ltd and The Energy Efficiency and Conservation Authority v Franklin District Council A148/2005*. This decision related to a resource consent application to establish a wind farm on the Awhitu Peninsula, south of Auckland.

The Court identified the benefits to be derived from renewable energy to include:

- Security of supply
- Reduction in greenhouse gas emissions
- Reduction in dependence on the national grid
- Reduction in transmission losses
- Reliability
- Development benefits
- Contribution to the renewable energy target.

The Court also gave considerable weight to the positive effects of renewable energy in its consideration of the decision and also found support for the project in its general assessment of Part II of the Act.

The 2004 amendment also removed the regulatory means for controlling greenhouse gases, as at the time when the Amendment Act was being developed, fiscal measures (namely the carbon tax) were being introduced to have the same effect. As a result, councils now cannot make rules which control the discharge of greenhouse gases on the basis that they contribute to climate change, nor can they consider climate issues in relation to resource consents. Rules relating to the control of greenhouse gases for climate change purposes made prior to enactment no longer apply. However, historic resource consent decisions still stand.⁵

In 2005, the Act was further amended by giving additional powers to councils to:

“the strategic integration of infrastructure with land use through objectives, policies, and methods:”

The amendment also provided a wide definition of infrastructure which includes:

“(a) pipelines that distribute or transmit natural or manufactured gas, petroleum, or geothermal energy:

⁵ A Private Members Bill is currently before Parliament that will effectively reverse these provisions.



“(d) facilities for the generation of electricity, lines used or intended to be used to convey electricity, and support structures for lines used or intended to be used to convey electricity, excluding facilities, lines, and support structures if a person—

(i) uses them in connection with the generation of electricity for the person’s use; and

(ii) does not use them to generate any electricity for supply to any other person:

These powers may be implemented by providing objectives, policies and methods in regional policy statements that will provide greater direction as to the locations and co-ordination of such infrastructure.

The 2005 amendment to the Act also changed the status of Regional Policy Statements. Previously District Plans were required to be not inconsistent with a Regional Policy Statement. The 2005 amendment altered this so that District Plans are now required to give effect to a Regional Policy Statement. This gives Regional Policy Statements additional powers to direct what provisions are included within District Plans.

Overall recent amendments to the RMA both require and empower Councils to have a greater role in the encouragement of renewable energy generation.

2.9 Barriers to Renewable Energy

There are a range of barriers that have slowed the uptake of renewable energy. These largely relate to the need for individual projects to secure their own “fuel” supply from natural resources while also still having to construct an energy conversion facility (*i.e.* power plant). The locations where these natural resources are found often have other intrinsic value (such as wind resources found in areas of high landscape value, or hydro opportunities in dramatic catchment areas) or the resource itself has other competing uses (such as recreational use of rivers, geothermal features as tourist attractions).

Some of the major barriers to renewable energy are identified in Table 2, along with a brief indication of where councils may have some influence on those barriers:



■ **Table 2 Major barriers to renewable energy projects**

Barrier	Description	Council Influence
High capital cost	Projects include the cost of “fuel” gathering as well as energy conversion and hence tend to have high capital cost. Some technologies are new and do not yet have the economies of scale in plant construction compared to conventional energy sources.	No influence
Intensive “fuel” investigation	Intensive investigation is required for determining resource potential. This is very high for geothermal but less for wind and hydro.	Consents for wind measurement towers, geothermal drilling and river weirs
Low energy density	Many renewable projects have a low energy density – requiring large areas for the collection of fuel and for energy conversion plant. However, some types such as wind and geothermal do not preclude continuation of other uses such as farming.	Land use that is allowed within human and natural land zonings.
Long development time	Most have several stages of development, from resource evaluation, consenting and construction. There are associated development risks at each stage.	Consenting process
Wide consultation Community attitude to natural resource uses	The use of natural resources and construction of plant in natural areas demands a high level of consultation often in the face of significant public opposition.	Planning environment Consenting process
Resources associated with natural features or areas of intrinsic or cultural value	Renewable energy can be associated with natural features that have high intrinsic value, such as wind in outstanding landscapes and hydro in natural waterways. These areas may also have special cultural value to Maori.	Landscape planning, natural area identification. Balancing effects of development against amenity values in consent process.
Competing uses for the same resource	Recreation use of rivers and irrigation competes with hydro power. Geothermal surface features have a range of uses.	Balancing effects and benefits from competing uses Resource consents to take water
High “mitigation” fees	Due the fact that objectors can impede the consenting process, many affected or interested parties now expect substantial fees in return for their agreement to a development. Consent requirements have resulted in a secondary mitigation fee market that is a barrier particularly for smaller projects.	Planning environment Consenting process
Non-firm nature	Some renewable resources such as solar, wind and marine are periodic or intermittent in nature. This limits their ability to meet peak demand requirements and hence tend not to	No influence



Barrier	Description	Council Influence
Transmission requirements	<p>secure highest market prices.</p> <p>Most renewable energy projects need to be located close to the energy resource and so are dependent on transmission networks to carry the energy to where it is required.</p> <p>Weak transmission networks limit positioning of projects.</p> <p>Developers may be required to build new transmission lines to service their projects.</p>	Consents and designations for transmission upgrades or new lines
Environmental considerations	<p>Councils may find it difficult integrating increased interest in renewable energy alternatives with local environmental concerns, already identified in existing or operative legislation.</p> <p>For example the use of biomass as an alternative to electricity could be viewed as an air quality problem, rather than an energy supply solution.</p>	<p>Planning environment</p> <p>Consenting process</p> <p>Non-regulatory</p>

Fossil-fuelled projects face few of these obstacles. For example two gas-fired power plants currently (2006) under construction did not require notified consents. The 1,000 MW⁶ Huntly plant has been reverted to being fuelled by coal so that the gas it would have otherwise used can be redirected to a new efficient CCGT gas-fired plant under construction. However, the conversion of the Marsden B plant to coal is subject to appeal on conditions by the developer and on environmental grounds by environmental groups opposed to the project.

Recent successful renewable energy projects have included an expansion to the Tararua wind farm and an expansion to the Mokai geothermal plant. These projects were located at existing power development sites and as such were readily able to obtain resource consents.

However, “green-field” projects tend to face greater difficulty within the RMA processes. The proposed expansions of the geothermal projects at Ngawha and Kawerau have been declined or face appeals because of perceived effects. Developments planned at new locations have had to follow a more difficult path. The hydro project “Aqua” was reportedly abandoned due to a perception of major public opposition, and several wind farms have faced similar opposition.

⁶ The unit for measuring power is the Megawatt (MW). Power is the rate at which energy is generated / consumed, i.e. 1MW means that one million joules of energy is generated / consumed every second. As crude approximations: a full petrol tank in an average size car contains one million joules of energy; a single wind turbine has a 1MW capacity



Developers report that small renewable projects are no longer viable to consider for development as the costs and delays associated with the consenting processes and the “mitigation” fees can be as great as for large projects. However, if fossil fuel costs and wholesale electricity prices continue to increase in line with recent trends then the higher market return possible for alternative energy sources will tend to enable the development of more renewable energy projects.

2.10 Potential Role for Local Government

While development of renewable energy resources can have benefits that are of national and regional value, these benefits apply to a variety of sectors and are often not manifested in a way that is tangible and of direct value to the individual developer. In the absence of direct financial or other enabling incentives, the wider national and regional benefits therefore may not surmount the barriers to most forms of renewable energy development.

This is the reason that central government has engaged in strategies to promote renewable energy. Some of the barriers to renewable energy development are manifested in the regions and districts, and the councils have a key role in the process for approving or declining these projects and more fundamentally, for establishing policies and plans that proactively support greater uptake of renewable energy. The Councils and their policy and planning instruments can therefore have a significant effect on the future uptake of renewable energy in New Zealand.



3. Technologies

This section provides a summary of technologies which are used to utilise renewable energies. Renewable energies are defined by the RMA as:

- Solar
- Wind
- Hydro
- Geothermal
- Biomass
- Tidal
- Wave
- Ocean Current

Of these, hydro and geothermal are relatively mature technologies, solar, wind and biomass are new and to some extent still developing, while tidal, wave and ocean current are still at the development stage.

3.1 Technical and Economic Considerations

The following paragraphs comment on some issues that affect cost estimates for renewable energy projects and future price trends. All the listed values in Table 3 for capacity factor and cost are indicative only. Renewable energy projects have generally very project specific cost components and need to be assessed on a case by case basis.

3.1.1 Wind power generation

Figure 9 shows the dependency of the generation costs from large scale wind farms on the average wind speed. Note that this graph is only an indication of likely costs for typical projects. Costs can vary significantly between projects, depending on complexity of the terrain and resulting higher costs for access roads or long distance to the grid with high investment needed for the grid connection. The graph shows that currently the electricity prices require average wind speeds of around 8 m/s for projects to be economically viable. A future increase in electricity prices will make areas with lower wind speeds attractive for developers also.

Wind turbine prices have dropped considerably over the last decade due to a large increase in manufacturing rates/capacities and technology enhancement. However, this trend is not expected to continue. Last year saw a general increase in turbine prices, which was partly due to higher steel prices. Furthermore, some manufacturers were forced to increase prices to avoid financial losses and make the business more profitable. Profit margins have been very small in the past due to a very competitive market.

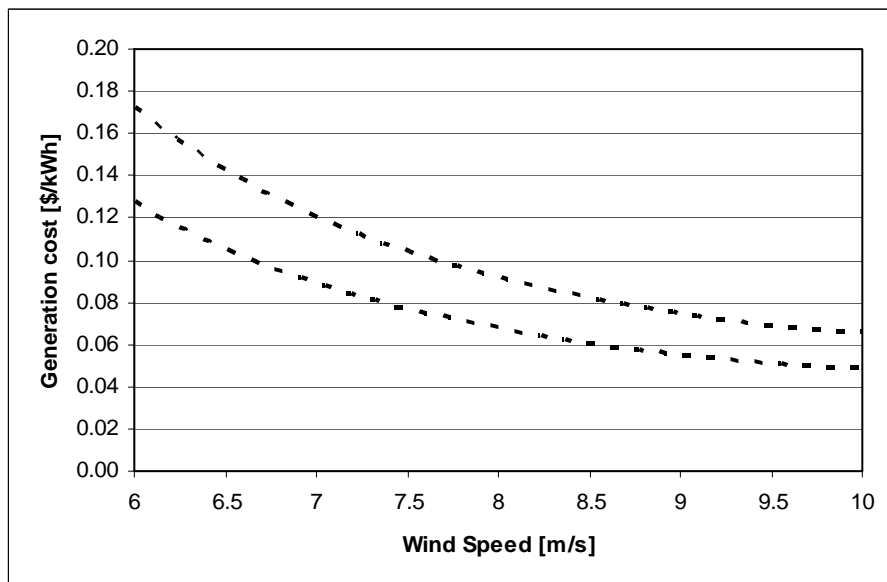

■ **Figure 9 Indication of wind energy generation costs**

3.1.2 Solar PV generation

Solar PV system costs have been dropping significantly over the last decade. Furthermore, the efficiency of solar cells is constantly improving. This trend is expected to continue with further production capacity lowering the costs, and further technology developments increasing the efficiency.

3.1.3 Solar thermal conversion

Technology used in solar thermal conversion systems continues to advance, reducing production cost and increasing system performance. Ongoing improvements to solar conversion surfaces and effective reductions in convection losses ensures solar thermal conversion efficiency continues to improve. It is believed that this technology will remain as the most economic solar conversion system available for installation in both new and existing houses.

3.1.4 Hydro generation

The wide range of cost of generation comes about because of the very site specific nature of projects. The necessary project components and their scale (for example diversion and water conveyance works, environmental mitigation works and choice of equipment) depend very much on the location and the intensity of the potential. Additionally site specific aspects such as topography and geology drive construction costs while local hydrology determines the energy available from the site. Whereas low head schemes have proportionally large (and slow speed)



generating units and relatively low civil works investments, the opposite is the case for high head opportunities where the (small, high speed) machine cost tends to be low, but with a relatively high investment in the diversion works and pipeline. The scheme's proximity to electrical grid, access to site and necessary transportation work (new roads vs. existing) can also affect the project cost substantially, as can the cost of capital (own or borrowed from the market) in the prevailing market conditions.

3.1.5 Geothermal power generation

Geothermal development costs have been relatively stable for some time, although drilling costs in particular have risen over the past year. Many of the recent geothermal power developments in New Zealand (*e.g.* Mokai, Rotokawa and Ngawha) have used wells that were drilled by the government many years ago, thus removing a significant cost and risk component. Similarly, expansion of those projects can draw on a production history that allows greater certainty as to the size of the resource and its capacity to sustain the expanded operation. For example, addition of a binary power plant at Wairakei did not require any additional wells to be drilled, and cost much less than the estimated costs in Table 3, which are for a stand-alone binary plant. Costs are significantly higher for green-fields developments where there are no existing geothermal wells, compared with expansion of an existing development.

The energy in ground at ambient (non-geothermal) temperatures (10-15°C in New Zealand) represents a significant energy resource which can be used with ground source heat pumps (GSHP). This technology is used on a large scale in North America and Europe where the climate, high electricity prices and subsidies make this technology economic. These drivers are largely absent in New Zealand and as a result there has been little use of GSHP's in New Zealand. Use of geothermal heat using ground source heat pumps can save up to 60% on electricity heating costs in a typical New Zealand home but, because of the high installation cost (approximately NZ\$12,000), may only be economic for larger commercial buildings.

3.1.6 Marine power generation

Marine power generation costs are expected to drop considerably over the next decade. It is expected that the cost curve will be similar to the wind power generation. However, it must be noted some cost components, especially Operation & Maintenance, can only be estimated with high uncertainty at this stage.

■ **Table 3 Renewable energy technologies**

Resource / Technology	Technology Description	Technology Status	Type of Application - size - heat / electricity - peak / base / capacity	Environmental Effects	Costs*
Wind					
Wind turbine	Extraction of kinetic energy from the wind flow Horizontal axis wind turbine 2 or 3 blades Direct drive or gearbox AC generation	Well established Commercially available	Large scale Typical modern turbine size 2-3 MW Wind farms up to 300+ MW Intermittent generation Capacity factor: 35-45% Difficult to forecast	Visual impact Noise Shadow flickering Electromagnetic interference	1,700-2,100 \$/kW (installed) approx. 8 c/kWh see comments above
Micro wind	Extraction of kinetic energy from the wind flow Horizontal or vertical axis turbines 2 or 3 blades Direct drive DC generation	Well established Commercially available	Small-scale (<10 kW) Electricity generation or direct drive of water pumps Intermittent generation Difficult to forecast	Minimal visual and noise impact	7,000-10,000 \$/kW 30-40 c/kWh
Solar					
Solar Thermal System	Solar radiation transformed into heat System consisting of solar collector and storage Active systems use a pump whereas passive systems rely on gravitational forces	Well established Commercially available	Small-scale, heat	Minimal visual impact	3,000-6,000 \$ per domestic system 11-17 c/kWh _{th}
Solar Photovoltaic	Solar radiation transformed into electricity Solar cells consisting of semiconductor material (either thick or thin technology) Silicon most common semiconductor material	Well established Commercially available	Small-scale, electricity Intermittent generation	Minimal visual impact	grid connected (incl. inverter): 13,000-20,000 \$/kW approx. 80 c/kWh

SINCLAIR KNIGHT MERZ

Resource / Technology	Technology Description	Technology Status	Type of Application - size - heat / electricity - peak / base / capacity	Environmental Effects	Costs*
Hydro					
General	Water passing through a turbine rotates the runner which is harnessed to a generator to produce electricity.				
Run of River	Divert part of river flows to power plant, may consist of small barrage or a weir to store little water at the water diversion area. Often requiring tunnelling to move water to location where head drop can be achieved.	Well established Commercially available	Small to medium scale electricity Capacity Factor: 70-80%	Water extraction, aesthetic effects, ecological effects, recreational activities	3,000-4,500 \$/kW 4-7 c/kWh
Storage	Dam creates water storage upstream of the diversion to be used to generate power on demand	Well established Commercially available	Medium to large scale electricity, peak load Capacity factor 50-70%	Land inundation, effect on aquatic ecosystems (change in habitat, fish migration), water quality, soil erosion, recreational activities, noise	3,500-5,000 \$/kW 7-10 c/kWh
Pumped Storage	In addition to storage at the diversion area, water also stored at the downstream end where spent water is released and pumped back up to reuse it to generate.	Well established Commercially available	Medium to large scale electricity, peak load	Land inundation, effect on aquatic ecosystems (change in habitat, fish migration), water quality, soil erosion, recreational activities, noise	2,500-4,000 \$/kW generation costs: N/A (net consumer)
Biomass					
Direct heat	Biomass (such as woodwaste etc) is burnt to generate heat, either directly or as steam or hot thermal oil.	Well established Commercially available	Available from the smallest domestic scale (wood stoves etc) to NZ's largest industries (pulp & paper).	Air quality may be affected by the smaller-scale developments. Large installations will have sophisticated emissions control systems. Fuel transport will have adverse effects.	Woody biomass: 4 \$/GJ
Electrical generation	Biomass is burnt to generate steam for a power plant.	Well established Commercially available	Economics favours the larger-scale developments,	Power plant developments will have sophisticated	20 MW class woody biomass plant:

SINCLAIR KNIGHT MERZ

Resource / Technology	Technology Description	Technology Status	Type of Application - size - heat / electricity - peak / base / capacity	Environmental Effects	Costs*
			typically greater than 25 MWe, but limited by harvesting and transport costs. Capacity factor: 90%	emissions control systems. Fuel transport will have adverse effects.	3,400 \$/kW 13 c/kWh
Liquid fuels	Very wide range of options for the production of liquid fuels, including hydrolysis and fermentation to ethanol, oil and tallow esterification to biodiesel, gasification and synthesis to methanol and hydrocarbons, pyrolysis etc).	Some technologies are well-established and commercially available (ethanol, biodiesel, etc), others are at prototype and/or early commercial stages (gasification and synthesis, pyrolysis, hydrolysis etc).	Economics favours the larger-scale developments, largely due to technical sophistication, but limited by distributed nature of the resource and the harvesting and transport costs.	Process plant developments will have sophisticated emissions and effluent control systems. Raw materials transport will have adverse effects.	Tallow and oils to biodiesel Plant capacity 120,000 t/year. Plant capital cost \$50 million. Feedstock cost \$460/t, product cost \$0.45/L. Biomass to Methanol Plant capacity 250,000 L/day. Plant capital cost \$250 M. Product cost \$1.1/L, \$61/GJ Biomass to Ethanol Plant capacity 100,000 L/day. Plant capital cost \$128 M. Product cost \$1.75/L, \$75/GJ
Gaseous fuels	Biological degradation (anaerobic digestion, fermentation etc) to generate methane gas.	Well established Commercially available	Available from the smallest domestic and/or farm scale bio-digester to municipal effluent treatment for NZ's largest cities.	Process plant may need sophisticated effluent control systems. Raw materials transport may have adverse effects.	
Geothermal					
Conventional geothermal power plant (steam turbine) possibly with binary plant for steam condensing.	Fluid self-discharges from wells. Steam and liquid water flows are separated. Steam is passed directly through a turbine to generate electricity. Binary plant possibly used for condensing steam and heat recovery from hot	Well established Commercially available, applicable to high temperature (typically >200°C) geothermal fields	Medium to large scale electricity (base load), plus downstream direct heat potential. Capacity factor 90-95%	Air quality (especially H ₂ S odour), impact on surface thermal features, shallow aquifers and ecosystems, noise, visual, subsidence, resource depletion	2,500-3,000 \$/kW 5 - 8 c/kWh

SINCLAIR KNIGHT MERZ

Resource / Technology	Technology Description	Technology Status	Type of Application - size - heat / electricity - peak / base / capacity	Environmental Effects	Costs*
	water. Waste fluids mostly reinjected into the ground.				
Binary power plant on medium to low temperature resources	Wells may self-discharge or require pumping. Geothermal fluid heats a secondary (binary) fluid in a closed cycle that is vaporised, drives a turbine, is cooled and condensed.	Well established Commercially available, most applicable to low temperature (120 to 200°C) geothermal fields. Applied in many USA fields usually with pumped wells. In NZ, binary plant presently only used for heat recovery from water on geothermal projects.	Small to large scale electricity (base load), plus downstream direct heat potential Capacity factor 90-95%	Air quality (especially H ₂ S odour), impact on surface thermal features, shallow aquifers and ecosystems, noise, visual, subsidence, resource depletion	5,000-7,000 \$/kW 7-10 c/kWh
"Enhanced" Geothermal systems (including Hot Dry Rock – HDR)	Geothermal reservoirs that have heat but insufficient water or permeability for conventional extraction. Multiple wells required for stimulating fractures and circulation of a fluid through injection-production well couples. Energy converted to electricity Potential on margins of existing NZ fields.	At developmental stage in USA, Europe and Australia. Large heat reserves in some geological environments, hence there is technology development effort.	Projects are likely to be large to enable economy of scale	Effects expected to be minimal compared to conventional geothermal. Some thermal contraction effects (v minor subsidence)	High cost
Direct use of heat: many potential uses, including:	Paper manufacture Timber drying Other industrial processes Space heating Space cooling Horticulture Aquaculture Bathing, spas	Well established Commercially available technology exists for most applications.	Range from very small scale (domestic heat pumps) to large scale industrial plants Capacity factor 90-95%	Depending on the scale of the operation, effects range from negligible to similar to a geothermal power plant	300-400 \$/kW _{th} 1-2 \$/GJ
Ground source heat pumps	Heat pump using the ground or groundwater as a heat source or	Well established Normally some measure of	Range from domestic to commercial building scale.	Minimal effects. If using groundwater, then	NZ\$12,000 estimated installation cost is higher

SINCLAIR KNIGHT MERZ

Resource / Technology	Technology Description	Technology Status	Type of Application - size - heat / electricity - peak / base / capacity	Environmental Effects	Costs*
	sink. Can achieve very high efficiencies compared to conventional heat pumps using atmospheric heat sinks. Typically used to heat or cool buildings.	custom design in NZ, as there are few suppliers. Wider application in USA, Europe, Japan and China.		affects water temperature.	than standard heating-cooling systems. Electrical input ~25-30% of output. Viable for commercial buildings if long term efficiency is considered.
Tidal (Kinetic Energy) Ocean Current	Exploitation of velocity component of tide. Flow of water passing turbine blades cause aerodynamic lift. Blades are connected via shaft to electrical generator				
Technology a1	Similar operating principle to vertical axis wind turbine. 2 or 3 blades mounted on a monopole seabed foundation	Large scale 300KW prototype demonstration 3 year sea deployment nearing completion. 1000KW grid connected demonstration prototype planned 2006-2007	In the order of 1MW per installation Electricity production Base load contributor – Energy BUT source intermittent but highly forecastable (years in advance) Capacity factor 40-50%	Yet to be fully understood but generic issues with: Sub sea noise especially in piling operations Marine mammal collision Risk to marine navigation and associated pollution risks Underwater cabling -Seabed and habitat disturbance -Electromagnetic interactions with elasmobranchs	Based upon estimates rather than track record: Early full scale prototypes 14,000 to 23,000 \$/kW Cost of energy range of 28-43 c/KWh Early production models 5,000 \$/kW Cost of energy approx. 22 c/KWh
Technology a2	As above but floating Vertical axis rotary device on mooring. Either fully submerged or surface piercing.	Number of 500KW grid connected demonstration prototypes planned 2006-2007	In the order of 1MW per installation Electricity production Base load contributor – Energy BUT source intermittent but highly forecastable (years in advance)	As above minus piling issue	as above

SINCLAIR KNIGHT MERZ

Resource / Technology	Technology Description	Technology Status	Type of Application - size - heat / electricity - peak / base / capacity	Environmental Effects	Costs*
			Capacity factor 40-50%		
Technology a3	Ducted turbine mounted on seabed via concrete foundation	1MW grid connected prototype demonstration planned 2006-2007	In the order of 1MW per installation Electricity production Base load contributor – Energy BUT source intermittent but highly forecastable (years in advance) Capacity factor 40-50%	As above minus piling issue	as above
Technology a4	Reciprocating aerodynamic foils convert mechanical motion into hydraulic rams power take off device.	100KW grid connected demonstration planned 2007	In the order of 1MW per installation Electricity production Base load contributor – Energy BUT source intermittent but highly forecastable (years in advance) Capacity factor 40-50%	As above minus piling issue	as above
Tidal (Head)	Exploitation of head differential between high and low tide.				
Technology b1	Impoundment (dam) of estuary. Gates within the dam allow water to pass upstream of structure. Closure of gates at high tide creates head height differential across dam as tide falls on downstream side. Operation reversed at low tide. Low hydro	Well established Commercially available technology exists for most applications.	In the order of 100MW per installation Electricity production Base load contributor – Energy BUT source intermittent but highly forecastable (years in	Profound and irreversible change in estuary eco-system	Existing plants are broadly comparable with the upper end of fossil fuel based generation costs Costs are expected to be much higher in NZ due to the lower tidal range.

SINCLAIR KNIGHT MERZ

Resource / Technology	Technology Description	Technology Status	Type of Application - size - heat / electricity - peak / base / capacity	Environmental Effects	Costs*
	turbines may then be used to release head and generate electricity.		advance)		Minimum tidal range currently considered economic for this technology is considered 5m.
Technology b2	Narrow headlands create 'nature' impoundment as head height can vary across the sides of the land mass. The introduction of piping containing water turbines exploits head driven flow.	Yet to be demonstrated at meaningful scale	In the order of 100MW per installation Electricity production Base load contributor – Energy BUT source intermittent but highly forecastable (years in advance)	Hazard to fish life passing through pipe. Estimated to be little eco-system impact	unknown
Wave					
Technology a	Oscillating water column: Conversion of wave energy into pneumatic energy, channelled through bi-directional air turbine connected to rotary electrical generator. Can be configured as floating structure, seabed fixed or fashioned into cliffs or breakwaters	Demonstrated at 500KW grid connected site. Presently with 4 year of operational service	Intermittent energy source. Forecast ability better than wind, but good reliability only based on future time period estimates of 6-8 hrs. Electrical generation 500-1500's KW size range per installation Capacity factor 40%	Yet to be fully understood but generic issues with: Marine mammal collision Risk to marine navigation and associated pollution risks (less if deeply submerged Changes in sediment transportation patterns Underwater cabling: -Seabed and habitat disturbance -Electromagnetic interactions with elasmobranchs	Based upon estimates rather than track record: Early full scale prototypes 11,000 to 26,000 \$/kW 63-72 c/KWh Early production models 7,000 \$/kW approx. 29 c/KWh
Technology b	Point Absorber: Conversion of wave heave motion into mechanical relative displacement between floating	Demonstrated at up to 100(?)KW power level in open sea	Intermittent energy source. Forecast ability better than wind, but good reliability only based on future time	Yet to be fully understood but generic issues with: Marine mammal collision Risk to marine navigation	as above

SINCLAIR KNIGHT MERZ

Resource / Technology	Technology Description	Technology Status	Type of Application - size - heat / electricity - peak / base / capacity	Environmental Effects	Costs*
	buoy on sea surface and other reference point. Variety of PTO options including; Fluid pumping (water or oil) Hose Pump Direct drive linear generator		period estimates of 6-8 hrs. Electrical generation + high pressure water pumping/desalination opportunities 100's KW size range per installation Capacity factor 40%	and associated pollution risks (less if deeply submerged) Changes in sediment transportation patterns Underwater cabling -Seabed and habitat disturbance -Electromagnetic interactions with elasmobranchs	
Technology c	Overtopping: Use of wall to focus wave energy into central location. Waves of certain size break over head wall and fill floating reservoir. Low head hydro turbines in floor of reservoir are connected to rotary electrical generator(s)	Demonstrated at up to 100KW level in open sea. Advance plans in place to deploy MW size device in 2007	Intermittent energy source. Forecast ability better than wind, but good reliability only based on future time period estimates of 6-8 hrs. Electrical generation 10's MW size range per installation Capacity factor 40%	Yet to be fully understood but generic issues with: Large mammal collision Risk to marine navigation and associated pollution risks (less if deeply submerged) Changes in sediment transportation patterns Underwater cabling -Seabed and habitat disturbance -Electromagnetic interactions with elasmobranchs	as above
Technology d	Attenuator: Semi-submerged, articulated structure of sections linked by hinged joints. The wave motion on these joints is resisted by hydraulic rams, which pump high-pressure oil through hydraulic motors which	750KW pre production prototype deployed. Commercial order placed for several devices for Portuguese deployment 2006.	Intermittent energy source. Forecast ability better than wind, but good reliability only based on future time period estimates of 6-8 hrs. Electrical generation 10's MW size range	Yet to be fully understood but generic issues with: Marine mammal collision Risk to marine navigation and associated pollution risks (less if deeply submerged)	as above

SINCLAIR KNIGHT MERZ

Resource / Technology	Technology Description	Technology Status	Type of Application - size - heat / electricity - peak / base / capacity	Environmental Effects	Costs*
	drive electrical generators		1-2MW size range per installation Capacity factor 40%	Changes in sediment transportation patterns Underwater cabling -Seabed and habitat disturbance -Electromagnetic interactions with elasmobranchs	

*Sources: General experience of SKM and NaREC gained in a number of different renewable energy projects
EHMS 2005 for solar thermal costs



4. Renewable Energy Potential

4.1 Introduction

This section reviews the existing and potential future renewable energy potential of the Northland Region, looking in turn at wind, solar, hydro, biomass, geothermal and marine energy.

4.2 Wind

4.2.1 Wind Resource

Overall, New Zealand has good wind resource due to its location in the roaring forties, but wind speeds vary considerably around the country (Figure 10). Both wind resource maps in Figure 10 have limited accuracy but provide a good indication of high wind areas. The NIWA map is derived from met station data whereas the Canterbury map is based on weather model data.

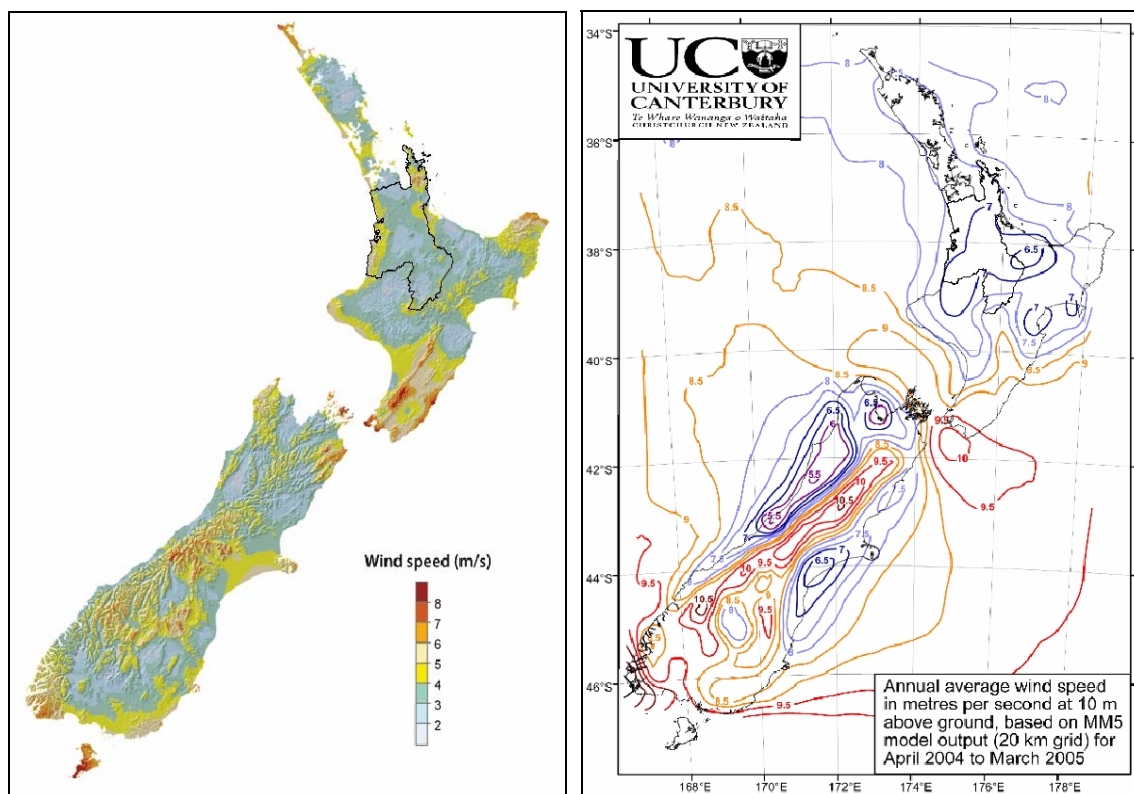

■ **Figure 10 Median and average wind speed at 10 m height (NIWA 2005a, Canterbury 2005)**



The wind speeds in the Waikato region are not among the highest in the country, which are generally found in the southern part of the North Island. However, some areas in the Waikato are likely to have average wind speeds of above 8 m/s, which is currently the approximate minimum wind speed required for economic wind farms. For comparison, wind speeds in the Tararua Ranges are about 10-11 m/s.

Earlier studies (EECA & CAE 1996, EECA 2001a) identified two potential areas in the Waikato region with sufficient wind speeds: the northern part of the west coast and the Coromandel/Kaimai Ranges. The wind speeds were estimated to be 8 and 9 m/s at 50 m height respectively.

Based on the more recently published wind maps it is estimated that there are a number of locations along the whole west coast with average wind speeds of around 8-9 m/s at 60-80 m height (this is the hub height range for modern large wind turbines). Most of the terrain is very complex, which requires onsite wind measurements to assess the wind conditions on a project by project basis.

Furthermore it is estimated that elevated and exposed areas north of Taupo also have sufficient wind speeds (around 8 m/s).

4.2.2 Potential Electricity Generation from Wind

Wind power generation has become a significant contributor to electricity generation in many regions around the world (especially Europe and US). There is currently 60,000 MW of wind power installed worldwide. Germany alone has almost 18,000 installed wind turbines with a total capacity of around 18,500 MW. The development of wind power in New Zealand had been delayed for many years because of very low electricity prices, which made it uneconomic to install wind turbines. Rising electricity prices during the last few years have changed this, and wind farms are now competitive with other forms of electricity generation. New Zealand's total installed wind power capacity of 170 MW is still very low though when compared internationally.

There are currently no wind farms in the Waikato region, but some wind farm developers have publicly announced their plans and projects:

- WEL Networks, Te Uku Wind Farm, 72 MW
- Ventus Energy, Taumatotara Wind Farm, 44 MW
- Taharoa C Corporation, Taharoa Wind Farm, 126 MW

It is difficult to accurately estimate the wind power potential for the Waikato region. SKM has spoken to a number of wind power developers active in the region. Due to the highly competitive market situation, they were not able to provide project locations or planned capacities (other than



the above). Those projects will only be made public once all landowner agreements have been signed and when there is high confidence about the viability of the project.

It is not only the wind speed that determines suitable areas, but a range of other factors including location of important natural features, proximity to population, site availability, topography, access and distance to electricity network or grid.

Figure 11 shows areas that will require careful and sensitive planning when proposing wind farms. Native forest and Department of Conservation (DoC) land can lengthen and complicate the consent process. Most of these areas are currently perceived as not suitable for wind farms. It can be seen that it may be difficult to obtain consents for some areas with high wind speeds. Due to high concentration of native forest and Department of Conservation land in the Coromandel and Kaimai Ranges, large scale wind farm development does not seem to be likely in that area despite the good wind resource.

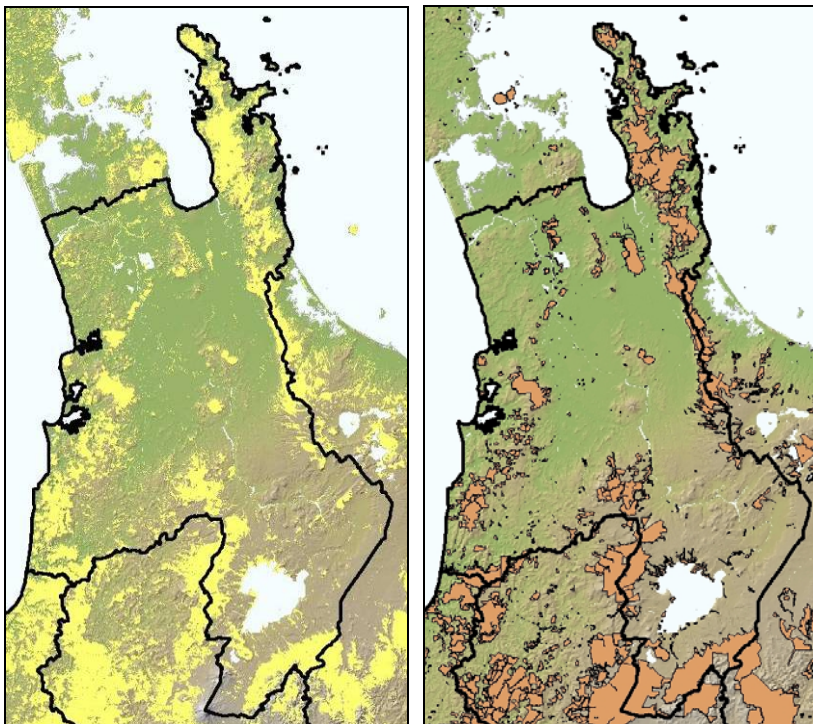

■ **Figure 11 Native forest (yellow) and Department of Conservation land (red)**

Very large wind farms (300+ MW) are not likely to be developed due to the region's topography and population density. There are no large ridgelines which could be used that are comparable to the Tararua Ranges or the Te Waka/Maungaharuru Ranges (Hawke's Bay), where the accumulation of wind farms can potentially lead to cumulative environmental effects. The wind



farms in the Waikato region are expected to be in the 50-150 MW range and located some distance from each other so that cumulative effects are less likely. Five to seven wind farms of that size could potentially be developed based on an initial screening of the region taking into account wind resource, topography, population density, distance to grid, accessibility and environmental factors (native forest and DoC land). Maps 3 and 4 in the Appendix show topography, infrastructure and native forest/DoC land.

The development of wind farms in the Waikato region is likely to cause some controversy as it does in other regions of the country.

If carefully planned, approximately 500 MW of wind capacity could be installed over a number of years with environmental impacts that were broadly acceptable to local communities, focused in the areas shown in Figure 12 (see Appendix 2 for a more detailed map). The technically available potential is much larger.

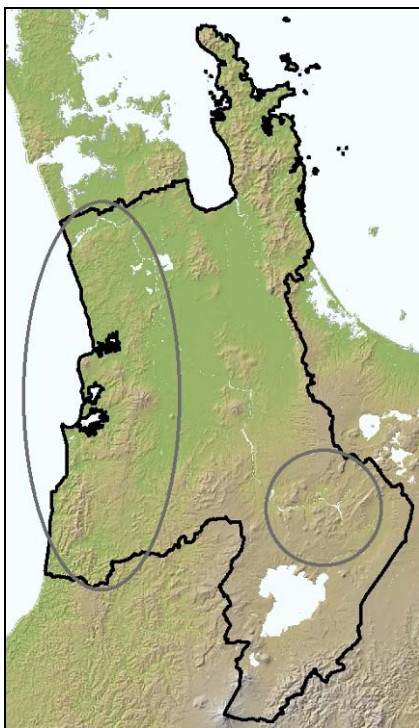

■ **Figure 12 Elevation map with potential wind farm areas**

The development of wind farms in the Waikato region needs also to be looked at in a nationwide context. Due to the intermittent nature of wind power there is a limit to how much wind power can be connected to the national grid. A recent study investigated the wind power integration limit (Energy Link & MWH NZ 2005). It was found that 20% of the nation's annual electricity



consumption could potentially be met by wind generation. This leads to a potential wind power capacity of around 2,000 MW (based on today’s consumption). There is currently only 170 MW of wind power installed in NZ but a number of large projects totalling more than 1,000 MW are under way or are being planned.

Small scale wind turbines (<10 kW), which are used for remote power supply, can successfully be operated in areas with lower wind speeds also. However, the lower hub heights (approx. 10-20 m) of these smaller turbines means more care needs to be taken when siting near local obstacles (*e.g.* trees and buildings). Small scale wind turbines will not play a significant role in future electricity generation, but they can become important for remote farms and settlements.

4.3 Solar

4.3.1 Solar Resource in the Waikato Region

Solar radiation across New Zealand is similar to that at many sites in Australia and higher than most areas in Europe (Table 4). Solar radiation for the Waikato region is approximately 1400 kWh/m²/yr, with no large variations across the region (Figure 13).

The solar radiation varies greatly over the year. Figure 14 shows the variation at 5 weather stations in the region. The given radiation data is valid for horizontal surfaces. The gain of solar systems can be easily enhanced by tilting the system towards north. Optimum tilting angle is the value of the latitude of the site. For example, an increase in the performance of a solar system in Hamilton of around 10% can be achieved by tilting the system by 37° towards north.

■ **Table 4 Typical values of total global solar radiation for several sites (EECA 2001b, NIWA 2006a)**

	MJ/m ² /yr	kWh/m ² /yr
Sydney	6150	1708
Melbourne	5302	1473
Kaitaia	5288	1469
Hamilton	5157	1433
Gisborne	5386	1497
Paraparaumu	5035	1403
Christchurch	4898	1360
Invercargill	4652	1292
Germany	3609	1003

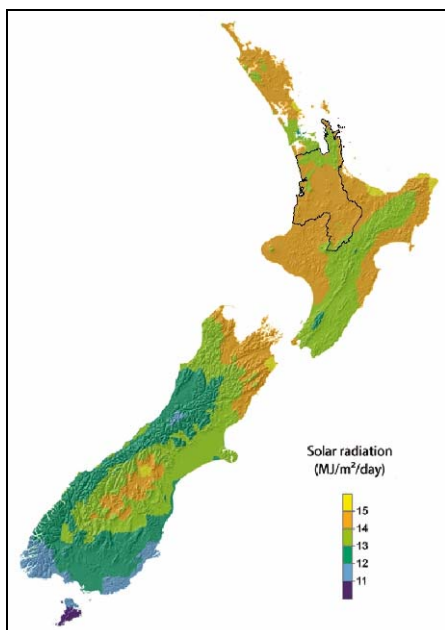

■ Figure 13 Solar radiation distribution (NIWA 2005b)

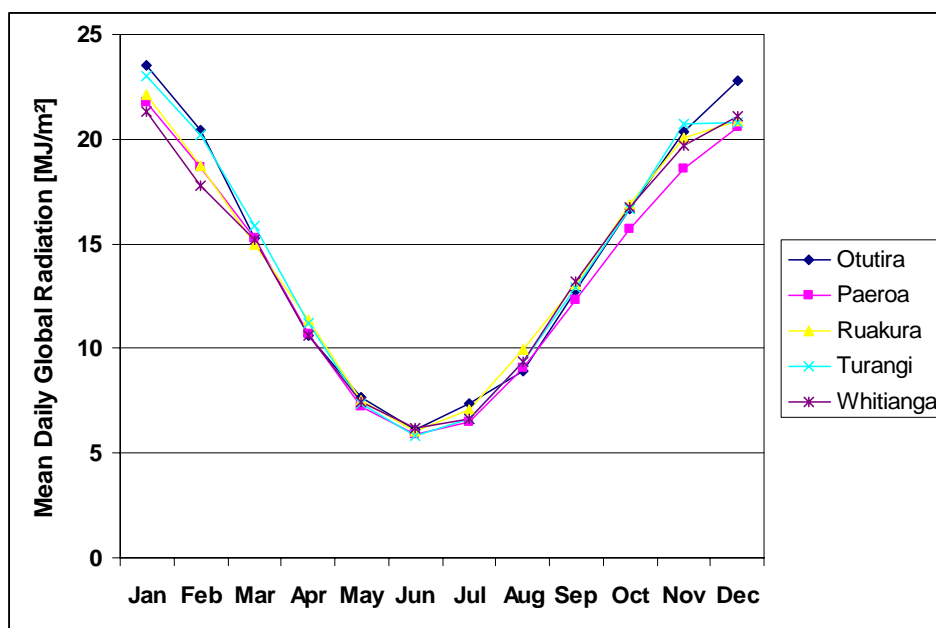

■ Figure 14 Monthly variation of solar radiation (NIWA 2006a)



4.3.2 Potential for Solar Thermal

Households account for 37% of electricity demand in the Waikato Region (EECA, 2004). Of this, about one third is usually for water heating (BRANZ 2004). A standard solar thermal system can produce around 55% of a household's water heating. Hence, the installation of solar thermal technologies has the potential to address some of the regions overall supply issues.

Solar thermal systems are most economic when installed in new buildings. Population growth in the Waikato Region has been slightly below the national average (for the 1996 to 2001 period). But the population was expected to grow another 11% from 2001 to 2021. Population growth varies between the different districts in the region. Districts like Franklin and Hamilton have had growth rates above the region's and even the nation's average. These areas have high demand in new housing and are therefore best suited for promotion and installation of solar thermal systems.

Overall, *there is potential for a substantial increase in the uptake of solar thermal use in the Waikato region.*

4.3.3 Potential for Solar Photovoltaic

The biggest barrier for the large scale uptake of PV is the high cost of the technology. Consequently, uptake has predominantly been for remote power supplies, enthusiast users and commercial developments where renewable energy has additional value as a corporate strategy or image statement. In summary, *the current high costs of solar photovoltaic means that large scale grid connected uptake in the region is unlikely, however small scale applications, particularly for remote power supply are expected to become more popular.*

4.3.4 Potential for Passive Solar Building Design

Solar space heating can significantly reduce the amount of energy use in new buildings. With solar space heating, the building is designed to maximise the absorption of solar energy. This can be applied to any building regardless of size or use (domestic/commercial). The building design considers building placement and orientation on the site and design features to capture, store and release solar energy in the building. Solar building design not only reduces the energy use, but it also can reduce moisture and condensation, improve sound insulation and provide a generally more comfortable and healthy living environment.



4.4 Hydro

4.4.1 Previous Hydropower Capacity Studies

The potential for developing the hydro-electric potential of New Zealand has been the subject of study for more than 100 years, the milestone reports being:

- 1) **The Hay Report (1904):** The earliest full assessment of New Zealand's hydro-electric resource was conducted in 1904, when North and South Island reports were tabled in the House of Representatives. Nearly all of the schemes which have so far been developed were identified in these original reports.
- 2) **Ministry of Works and Development (1982):** MWD undertook a comprehensive assessment of the country's small and medium scale hydropower potential in the period 1978 to 1985, establishing a consistent assessment methodology to look for sites with a potential installed capacity in the range 500 kW to 50 MW assuming a typical plant factor of around 50%. The work involved a review of maps, gauged river flows and topography to identify opportunities for harnessing water power. Local features of the most promising sites were then assessed and preliminary concepts were devised. Tonkin and Taylor (1982) made an assessment of the Waikato Valley Authority Area and concluded a potential total installed capacity of around 200 MW from approximately 50 sites in the 500 kW to 50 MW range. The potential schemes including the ones identified in Works (1990) with their scheme parameters are tabulated by catchment area in Appendix A and their locations are shown on Map 1 (Appendix B). The MWD report series did not include the Coromandel area or Waihou and Piako catchments, because historically these areas were administered by Hauraki Catchment Board, which only amalgamated with other councils and the Waikato Valley Authority to form Waikato Regional Council in the 1980s.
- 3) **WORKS (1990):** Another nationwide survey was undertaken by WORKS which summarised the large schemes (>10 MW) from previous studies and went on to consider the practicability of some of the major schemes including some very large opportunities in South Island. This study concluded the Waikato region had the potential for five hydro-electric schemes with outputs exceeding 10 MW with an 'apparently practical' total potential of 167 MW.
- 4) **Ministry of Economic Development (2004):** In their 'Waters of National Importance' report, East Harbour Management Services considered the hydro-electric resources of New Zealand. A 'publicly known' nationwide future hydropower potential of around 2,500 MW is considered, recognising also that there are possibly a significant number of opportunities not publicly identified. In the Waikato region, four schemes were considered in the 'high' and 'medium' confidence category, having a combined capacity of 25 MW, equivalent to 1% of the national potential.
- 5) **EECA Renewable Energy Industry Status Report (2005):** On behalf of EECA, East Harbour Management Services went on to report on the nationwide potential for additional



renewable power generation. On a national basis, the report estimated an additional annual hydro potential of some 4,260 GWh (equivalent around 900 MW with a typical plant factor of 50%). Cost estimates were based on escalating the MWD data from the 1980's. In the Waikato region, though not specifically located, eight schemes having generation costs below 16 c/kWh (@10% weighted average cost of capital (WACC)) were considered, having a total potential capacity of 76 MW.

- 6) **Ministry of Economic Development (2005):** East Harbour Management Services reported on the overall scope and cost ranges for generating electricity and heat from renewables. In the Waikato region an additional two hydro schemes were identified, though the scheme(s) previously identified as 'high confidence' appear to have been dropped.
- 7) **Electricity Commission (2005):** As part of the Electricity Commission's Statement of Opportunities a report was compiled by Parsons Brinckerhoff which provided a summary of all previously identified schemes – large and small. The report included cost estimates escalated from the MED report and developed ranges of possible cost (on a theoretical basis only) for schemes not previously estimated. The report summarised the schemes from previous references

4.4.2 Background

For implementing its river and catchment services, Environment Waikato divides the Waikato Region into eight management zones and four major catchments. We consider the Waikato River in three sub-catchments (Lake Taupo, Waikato River and Waipa), dividing the region into six main catchments as follows:

■ **Table 5 Environment Waikato – Management Zones and Catchment Areas**

Management Zone	Four Catchment	Six Catchment	Catchment Area (km ² x 1000)	
Lake Taupo	Waikato River	Lake Taupo	3.4	
Upper Waikato		Waikato River	3.2	
Middle Waikato			1.7	
Lower Waikato			2.8	
Waipa		Waipa River	3.0	
West Coast	West Coast	West Coast	4.2	
Waihou/Piako	Waihou , Piako	Waihou, Piako	3.6	
Coromandel Peninsula	Coromandel	Coromandel	2.0	

The catchment areas are shown in Map 1 (Appendix B).



4.4.3 The Developed Hydropower Resource

A total hydro capacity of 1378.7 MW is installed in the Waikato Region, making over 26% of the nations total hydro capacity. This is summarises the developed hydropower capacity in the EW region (Table 6).

The locations of existing hydropower schemes are shown on Map 1 (Appendix B).

■ **Table 6 Developed Hydro-Electric Schemes in the Waikato Region**

Catchment Area	Management Zone	Scheme ^(a)	Scheme Rating (MW)	Year	Owner/Operator
Lake Taupo	Lake Taupo	Rangipo (3)	120	1984	Genesis Energy
		Tokaanu (5)	200	1973	Genesis Energy
		Kuratau (2)	6.0		Todd Energy
		Hinemaiaia (4)	6.2	1952 to 1983	TrustPower
Waikato River	Upper Waikato	Aratiatia (7)	84	1928	Mighty River Power
		Ohakuri (8)	112	to	
		Atiamuri (9)	84	1964	
		Whakamaru (10)	100		
		Maraetai (11)	360		
		Waipapa (12)	51		
	Middle Waikato	Arapuni (13)	171		Mighty River Power
		Karapiro (14)	90		
West Coast	West Coast	Wairere (6)	0.5	from 1925	Todd Energy
		Mokauiti (1)	1.8		Todd Energy
TOTAL			1378.7 MW		

^(a) Figures in brackets are 'Map 1 - Existing Hydro Schemes' Reference Number

The Tokaanu power station captures approximately half of the runoff from Mt Ruapehu via the Eastern and Western Diversions. The far end of the Eastern Diversion (gathering flows from the southern slopes) and the annual storage provided by Lake Moawhango is located in the Wanganui region, with the flows conveyed by tunnel. The large storage provided by Lake Taupo is controlled by gates at the outlet.

The hydro-electric development of the Upper and Middle Waikato River has been extensive, and the stretch between Lake Taupo and Hamilton was fully developed in the period 1928 to 1964 by eight schemes in cascade having an installed capacity of 1040 MW. The Waikato cascade power stations were typically, and conventionally, designed for a plant factor in the range 50% to 60%.

In addition to the existing generation, King Country Energy has applied for resource consent for a 9.35 MW hydro development on the Mokau River.



4.4.4 The Market for Hydropower Development

Since the cornerstone MWD (1982) report, the electricity industry in New Zealand has undergone significant changes. Different scheme design drivers apply today, affecting the way that the originally conceived schemes would be viewed as investment opportunities, in particular the need for a developer to keep to a minimum the risks and uncertainties associated with environmental effects, ground risk and hydrology.

Though hydropower technology is relatively mature, some technological improvements have been made in civil works, and plant construction and equipment efficiency. For example, the use of a tunnel boring machine (TBM) might nowadays allow a dam to be avoided and for an alternative scheme layout to be considered. Additional infrastructural development such as new roads and transmission/distribution lines may have helped to improve project economics, though conversely, more onerous consenting changes and environmental requirements may make some projects less feasible.

The distributed and small scale nature of small, mini and micro hydro and their ability to act as standalone projects make them a ready source of energy for remote areas. However, remote sites can tend to increase construction costs, plus a long transmission line to connect to the existing grid can be costly and result in significant transmission losses. Projects having water storage can interact positively with, and firm other sources of power generation such as wind, whereas run-of-river projects are generally not able to guarantee a firm energy supply due to rainfall seasonality.

4.4.5 Possible Future Hydropower Potential

Lake Taupo

The Lake Taupo catchment includes more than 5,500 km of watercourses, with the lake itself occupying an area of over 600 km². As well as the rugged highlands and native bush regions, developed land areas include production forestry and farm pasture.

Potential exists for hydropower development of the larger rivers and streams draining into Lake Taupo, including the upper reaches of the Waikato River and the Mangatoetoenui and Waihohonu Rivers. The combination of large catchment, high rainfall and steep river gradients offer opportunities for developing reasonable outputs over relatively short reaches.

The Western Taupo area has moderately high rainfall and small catchments but the steep reaches of river with rapids and waterfalls provide substantial head over short reaches and create opportunities for hydro generation. The Kaimanawa area in the south east of Taupo has moderate sized catchments that produce river flows exceeding 2 m³/s that combine with steep river reaches to offer potential for small hydro generation.



Waikato

Though the daytime tourism value is clearly high, Huka Falls represents a significant potential at around 40 MW and it may be possible for a scheme to be configured without substantially affecting the visual flow. Smaller schemes (~5 MW) have also been postulated at the site.

There are opportunities above and below Papariki and at the Narrows downstream of Karapiro. The potential in the Middle Waikato River has been substantially exploited, but there are opportunities in its tributaries. Some projects have been identified in the Mangatahe, Waipapa, Mangawhio and Pokaiwhenua streams.

MED (2004) reported the conceptual opportunity for pumped storage or flood storage project(s) where a dam might be located in a tributary, and flows may be pumped from the Waikato, presumably at times of low electricity price or flood. Clearly a conventional pumped storage energy trading scheme would not be viable on its own, though the benefits of flood storage are not known.

Waipa

In the upper reaches of the Waipa some potential hydro sites have been identified at Owiwi Falls, Tunawaea Stream and on Waipari Stream. The Waipa River itself is not suitable for conventional hydro development because flows in the upper regions are inadequate to warrant construction of a dam and in the lower reaches there are no suitable locations.

West Coast

The principal rivers in the area are the Marokopa, Awakino and Mokau. A significant (40 MW) scheme is possible in the lower Mokau below Wairere Falls. South of Te Kuiti, several potential sites exist around Wairere Falls and on the Mapiu Stream. The northern part of this area has some potential sites on Marokopa and Tawaru Rivers and the Makomako Stream. Micro and mini hydro potential in the region tends to be disadvantaged by difficult access and remoteness from transmission line connections.

Waihou and Piako

The topography of the majority of the Waihou and Piako catchment area is relatively flat, but there may be potential locations for hydro generation as follows:

- Numerous reasonably steep, though short, streams on the western slopes of Kaimai and Coromandel ranges flowing towards Waihou River, including the Ohinemuri tributary flowing through Paeroa
- Longer, but also narrow, steep catchments on the Western flank of the Mamaku plateau where the Waihou River and the Oraka stream are sourced



The quantification of the hydro potential from these streams would need detailed study but there could be potential micro hydro sites on these streams where localised steep drops and sufficient flows exist. It may be possible to make some preliminary theoretical assessment of potential using data from a modern geographical information system (GIS). This would enable river reaches with reasonable gradient to be identified and scheme energy derived from average flows (in turn assessed from a calculation of catchment runoff).

There are some planned flood protection works in the Waitoa River, a tributary to Piako River, that consists of floodgates which may provide some opportunity for hydro generation.

Coromandel Peninsula

The Coromandel Peninsula features a rugged, steep-sided topography with high rainfall and mountain peaks at over 700 m. The streams and rivers are subject to 'flashy' flows with relatively high concentrations of sediment.

The hydro-electric potential is not known to have been assessed in detail before, though from an overview of maps there are some significant tributaries around the Tairua and Wharekawa rivers which might be capable of conventional 'diversion type' development (weir and penstock feeding a powerhouse). The remaining potential would probably typically comprise mini or 'micro' (<500 kW schemes) which might be exploited around localised drops where sufficient combination of head and flow exist.

Quantification of the hydropower potential would have to be the subject of detailed study on a site-specific basis, though it would seem that some reasonable schemes could be developed in the lower stream reaches. However, significant areas appear to be Department of Conservation land and Native Forest area and would affect any hydropower development in the region.

4.4.6 Other Possible Hydropower Options

Beyond the potential for conventional new hydro installations (developing head and diverting flow to generate electrical power by conventional water turbines), other means of increasing the contribution of hydropower include:

Rehabilitation and/or Uprating of Existing Plant

Modernisation and refurbishment of the water turbines and generators at existing hydropower schemes can typically realise an increase in output of 10 to 20% and/or (depending on their relative value in the power market) additional energy across the operating envelope of typically 2 or 3%. For the Waikato cascade, where much of the original plant installed over 40 years ago remains, this might represent an equivalent power increase of some 10 to 20 MW.



Alternative Technologies

There are some experimental technologies that in the future may become viable to harness hydro potential. Helical turbines for example (for 'ultra low head' applications) are a reaction crossflow machine, developed between 1993 and 1995 at Northeastern University in Massachusetts. The turbine operates in the streamflow and extracts energy from the stream velocity. Steep reaches in rivers with water velocities >1.0 m/s can provide potential sites for machines in series.

Other new technologies evolving, intended to reduce the complexities and capital costs of small hydro schemes, and for 'modular' applications, include siphon type turbines, variable speed and PMG generators and plastic pipelines. For the very small schemes, waterwheels with gearboxes or belt-drives can still have a place.

4.4.7 Summary

The potential for hydro-electric developments in New Zealand has been the subject of study for more than 100 years, with the largest and most economic schemes already having been developed sequentially in response to the rising electricity demand.

The only substantial regional assessment to have included specific site assessments and to have included original indicative costings is that of MWD (1982). A number of reports since then have updated and re-categorised the same sites, each time with different definitions of practicability and ranking, which tends to make any direct comparison difficult.

In summary:

- Several medium scale projects appear possible (Waikato and Mokau) with a combined capacity of around 149 MW. However, the schemes identified on the Mokau River (69 MW) appear to be within or near the Department of Conservation land or Native Forest area.
- Approximately 47 'mini' or 'small' scale projects are believed to be possible with a combined capacity of some 150 MW.
- Though in total the contribution is likely to be significant, for reasons that include the dispersed nature of the resource, technical and regulatory complexities, proportionally high development overheads, and landowner issues, the 'micro' hydro potential has never been identified.

Additional potential hydro sites can be identified through the use of modern GIS techniques using updated geographical information. GIS techniques can be used to isolate reaches of rivers with reasonable slopes and to estimate flows to determine the theoretical energy potential of the site. This will be especially relevant in determining small, mini and micro hydro sites where this type of screening approach would potentially be very useful.



While the prime driver for the uptake of the remaining hydro potential will be market forces (e.g. energy prices, relative cost of alternatives), other aspects such as consenting requirements and necessary environmental mitigation will also impact. Factors that can positively affect the uptake may be improved technologies that increase generation efficiency, improved construction methods that allow alternate scheme layouts, and infrastructure developments, such as road and transmission lines, that improve project economics.

The installed hydro capacity within the Waikato Region is almost 1400 MW, 99% of it on the Waikato and Tongariro rivers. The remaining hydro potential is about 300 MW in mini, small, and medium scale projects. Among these around 100 MW from approximately 13 schemes appear to be outside the Department of Conservation Land and Native Forest areas. The micro hydro potential has not been assessed.

4.5 Biomass

4.5.1 Biomass Resource in Waikato Region

The resources for the production and use of biomass as a renewable energy resource include agricultural crops, dairy and livestock farming, forestry and the residues associated with production and processing of those.

The Waikato region is potentially a major source of crop-derived biomass, although much of the region is better suited to pastoral farming (livestock and dairy), as indicated in the regional land use map (Figure 15). The area considered suitable for energy cropping, principally that area limited to a slope of no greater than 8°, is around 450,000 ha (Enconsult, 1981). The Hauraki Plains is an area that is particularly well suited to intensive cropping on a substantial scale.

4.5.1.1 Agricultural Crops for Energy

A wide range of crops can be grown in New Zealand that are suitable for renewable energy production, including both thermal and electrical energy and transport fuels. These include:

- grain crops - maize, wheat, oats and barley
- root crops - fodder beet, sugar beet, potatoes
- oil-seed crops - rape, linseed,
- herbaceous crops – kale, sweet sorghum, grass and lucerne

New Zealand produces around 950,000 t/year of grain and seed crops (Statistics NZ, 2002) with barley, wheat and maize grain being the leading components. Peas and other pulses contribute an additional 33,000 t/year. The starches in grains and pulses are readily converted to sugars and then fermented to produce ethanol. These crops are the basis of the very large “corn-based” fuel alcohol



industry in the US. Blends of 10% ethanol in gasoline, known as “gasohol”, are widely available throughout much of the US.

Oil seed production in New Zealand is much smaller, at around 5000 t/year, and also highly variable. Most of the oil-seed production is based in the lower South Island. Vegetable oils are attracting increasing interest as a raw material for the production of transport fuels, especially “biodiesel”, but it is unlikely that these crop-based routes to transport fuels could compete with New Zealand-sourced tallow for biodiesel production.

Starch, sugar or cellulose-based feedstocks from New Zealand sources are unlikely to compete with imported ethanol from Brazil or Australia.

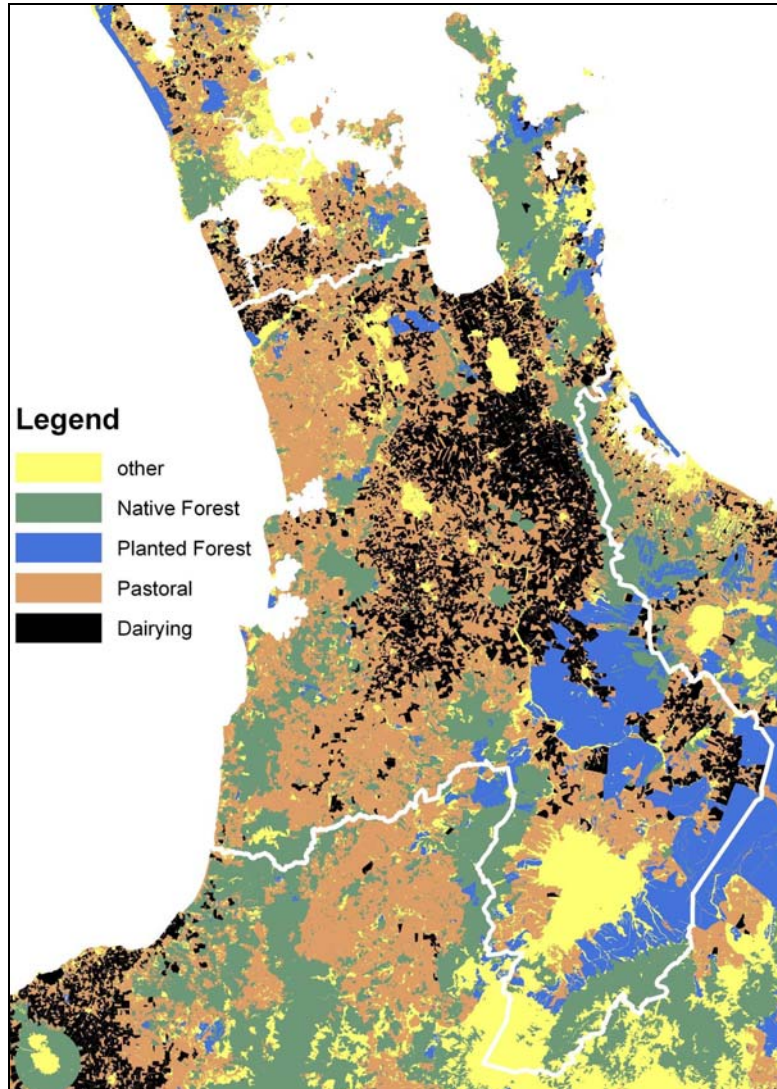

■ **Figure 15 Waikato land use map**

The Waikato region is the largest producer of maize grains, at nearly 40,000 t/year. This production was derived from only about 4000 ha, indicating that the level of production could be increased significantly using just a portion of the available 450,000 ha of arable land in the region. The current level of grains production (around 40,000 t/year, principally maize) could provide for the manufacture of 20 ML/year of ethanol.

The climate and soils of the Waikato region are well suited to root crops and somewhat higher yields, averaging around 10 ODt/ha, may be achieved with beet crops in particular, i.e. sugar beet and fodder beet. The manufacture of transport fuel from beet crops grown on the currently cropped 9,500 ha could deliver around 17 ML/year of ethanol.



If as much as 25% of the available arable land in the Waikato region (i.e. around 110,000 ha) was used for the production of energy crops, it would be theoretically possible to produce approximately 550 ML of ethanol.

Oil seed cultivation is not common in the Waikato, presumably because of production economics rather than an adverse climate or unsuitable soils. Yields of oil-seed rape in Southland are typically in the order of 1.8 ODT/ha, equivalent to nearly 700 L/ha yr of oil for biodiesel from this crop. Oil seed yields for the Waikato region are not known.

4.5.1.2 Forestry and Wood Processing Residues

Forestry has the potential to be a very major supplier of biomass for several types of renewable energy. New Zealand has around 1.75 million hectares of planted production forestry which is being harvested at a rate of 50,000 ha/year, producing around 22 million cubic metres of timber.

The Waikato region included 380,000 ha of planted production forestry in 2004 (MAF, 2005). 130,000 ha of this area is classified as “unpruned and without production thinning”, indicating that it would be valued at the lower end of the scale, suitable for pulping, fibre-based manufacture (MDF *etc.*) or for energy.

Production of liquid fuels from just the “unpruned and without production thinning” forestry resource in the Waikato region, without recovery of the harvesting residues, could result in around 440 ML/year of methanol or nearly 200 ML/year of ethanol. Use of this material in a “dendro-thermal” power plant for electrical generation could support an aggregate generation plant capacity of around 100 MW_e and could generate some 800 GWh/year.

4.5.1.3 Short Rotation Woody Biomass for Energy

In areas identified as suitable for the supply of woody-biomass, and where subsidies are available for sustainable energy production, it is increasingly common to find the cultivation of fast-growing, coppicing species such as willow, poplar *etc.* This is usually grown as fuel for dendro-thermal power plants, but may also be used as a cellulose feedstock for the production of ethanol via hydrolysis, fermentation and distillation.

Small-scale cultivation trials of *Salix* (shrub willow) are currently underway in Taupo with the expectation that the production would form the basis of fuel ethanol and possibly bio-polymer industries. The suitability of such fast-growing and machine-harvestable sources of woody biomass, and the relative economics of production, will not be known for several years.

4.5.1.4 Livestock Farming – Dairy and Meat

As indicated in Figure 15, the Waikato region includes large areas of pastoral farming.



Dairy processing residues

The Waikato is the foremost dairy region in New Zealand by far, with around 6500 dairy farms and an aggregate dairy herd of more than 1.7 million. The region produces and processes around 6000 ML of raw milk per year. Much of the milk from this region is converted to products such as skim-milk and full-milk powders, but there are several other products, especially cheeses, from which lactose-containing whey is produced. Some of these lactose-containing streams are concentrated for transport to Kapuni (South Taranaki), the North Island's only lactose production and refining facility.

Additional lactose streams of appropriate quality are fermented and the ethanol recovered by distillation at three North Island sites, one of which is within the Waikato region. This plant, at Tirau, produces around 5 ML/year of distilled ethanol.

Dilute dairy effluent streams, some containing residual biodegradable materials, may be amenable to anaerobic digestion, producing biogas. Although of relatively low calorific value, this biogas may be used directly for heat-raising or electrical generation.

The remaining lactose-containing effluent streams, for which recovery or processing are regarded as uneconomic, are disposed of to local waterways or spray-irrigated onto adjacent farms. The quantity of uncommitted lactose (from whey) was estimated at 100,000 t/year in 1980 (Enconsult, 1981). By 2006 substantially more of this whey resource is likely to be recovered and processed to high-value products.

Meat processing by-products

New Zealand produces almost 150,000 t/year of animal fats (*i.e.* tallow) from meat processing plants. In past years much of New Zealand's tallow production was used locally for soap manufacture, but most is now exported. Tallow may be used in the manufacture of biodiesel by means of a relatively straightforward esterification process.

Of New Zealand's 150,000 t of tallow produced in the year ending March 2006 (J O'Connell, pers. comm., Statistics New Zealand), some 147,800 t was exported. Of this tonnage, more than 400 t was edible grade tallow with an average value of around NZ\$1,300/t FOB. The balance of nearly 147,400 t consisted of inedible grades with an average value of NZ\$500/t FOB.

There are several meat processing plants and abattoirs in the Waikato region, many of which have rendering plants to recover tallow. Accurate figures are difficult to obtain, but we have estimated that the Waikato region produces around 90,000 t/year of animal fats that could be converted to biodiesel.



4.5.1.5 Municipal Solid Waste

Municipal solid waste (MSW) is included in this investigation and report on the basis that a proportion, the organic portion in particular, may be regarded as a renewable resource. The population of around 360,000 in the Waikato region generates around 210,000 t/year of household waste, of which around two thirds is organic. The remainder is principally glass, metals and building materials.

In addition to the household waste, another 200,000 t/year of solid waste is produced by business and industry, of which at least 50% is understood to be organic – largely paper, cardboard and assorted plastics.

Anaerobic digestion

The anaerobic digestion of wet organic wastes (other than plastics) produces biogas, typically a mixture of methane and carbon dioxide with the methane content ranging from about 45% to 60% (CAE, 1992), sometimes as high as 80% by volume (dry basis) (East Harbour, 2005) and a calorific value between 12 and 30 MJ/m³.

No New Zealand councils or waste disposal contractors are known to be using bacterial digestion processes for disposal of solid wastes, although appropriate technology is available.

Anaerobic digestion of MSW occurs naturally in landfills where it is a by-product of spontaneous bacterial action. Relatively few of NZ's older landfill facilities were set up specifically to maximise the production of biogas, to contain it or to provide for its recovery and use. Although a few of the older landfill facilities have been subsequently developed for landfill gas production, the recovery rates are modest and much of the methane is lost to the atmosphere.

As older landfill facilities are closed, however, the newer and larger landfills are required to comply with the National Environmental Standard which was introduced in 2004. Under this standard, there must be provision to destroy the methane, either by flaring the gas or using it as an energy source.

Waste combustion

Waste combustion is widely used in many other parts of the world, Europe in particular, where landfill disposal of waste is becoming increasingly unacceptable.

Of the more than 400,000 t/year of MSW generated in the Waikato region, almost 250,000 t/year is combustible material with an average calorific value of around 10 MJ/kg. Despite the relatively low calorific value, combustion of this material would produce around 140 GWh/year of electricity.



4.5.1.6 Sewage

Domestic sewage and liquid industrial wastes are collected from almost all municipal areas and reticulated to central plants for treatment and disposal. Typical quantities of domestic wastewater amount to 200 l/person-day, equivalent to a volumetric flowrate of 23,000 m³/day for the city of Hamilton.

Total (dissolved and suspended) solids in the wastewater are expected to be in the range of 700 to 1000 g/m³, amounting to as much as 23 t/day of total solids.

Anaerobic digestion

Treatment of sewage typically involves a flocculation and sedimentation stage to increase the solids concentration and then sludge digestion by aerobic and/or anaerobic processes. Anaerobic digestion produces between 0.75 and 1.12 m³ of biogas for every kg of volatile sewage solids destroyed, amounting to as much as 3000 m³/day for Hamilton City. This biogas will have a methane content of between 65 and 70%, by volume, equivalent to nearly 900 kW_{th} on a continuous basis.

Sewage sludge drying and combustion

Sewage solids have been segregated, dried and burnt for over 100 years and modern sewage treatment plants around the world are routinely disposing of sewage solids in this manner. Where sewage solids are recovered from treatment plants in New Zealand they are usually disposed of to landfill, although there are two cities where sludge drying and alternative disposal options are available. Sewage sludge drying and combustion trials are underway in both Hamilton and Auckland with the objective of reducing the high costs of transport and landfill disposal.

Combustible solid recovered from Hamilton's digested sewage sludge has a calorific value of around 16 MJ/kg (bone dry basis). Despite the apparently high calorific value, the net recoverable energy from the combustion of sewage solids is relatively low, mainly due to the high energy demand associated with drying, sterilisation of the emissions and odour control.

4.5.2 Technology

4.5.2.1 Transport Biofuels

A range of transport fuels may be produced from biomass sources. These include:

- Biodiesel – from oil-seed crops, oil-bearing plants such as jatropha, and animal fats, via transesterification
- Ethanol – via direct fermentation from sugar, grains and root crops as well as via hydrolysis and fermentation from cellulosic material such as wood, straw *etc.*



- Methanol – via gasification of almost all biomass and catalytic re-combination of the resulting synthesis gas
- Biogas – via anaerobic digestion of almost all biomass
- Pyrolysis oil - by the pyrolysis of biomass material and the subsequent separation and refining of the produced liquid.

Biodiesel

Biodiesel is a clean burning transport fuel produced from renewable resources including oil-seed crops and animal fats. Biodiesel contains no petroleum, but it can be blended at any level with petroleum diesel to create a biodiesel blend that can be used in compression-ignition (diesel) engines with little or no modifications. Biodiesel is simple to manufacture, biodegradable, non-toxic, and is free of sulphur and aromatics.

The technical definition for biodiesel (NZS7500:2005) is “a fuel comprised of mono-alkyl esters of long chain fatty acids derived from vegetable oils or animal fats. Typically these are methyl esters or ethyl esters, however higher alkyl groups can be used.” The New Zealand standard appears to follow the US standards (ASTM D 6751 in particular) reasonably closely.

A biodiesel blend (Bx) is a blend of biodiesel with mineral diesel fuel, where “x” represents the volume percentage of the biodiesel component in the blend. Biodiesel blends in New Zealand are presently limited to no more than 5% biodiesel by volume.

Ethanol

The production of ethanol from agricultural biomass is well developed technology. Very large quantities of ethanol are currently manufactured from cane sugar (cf. Brazil) and grains (cf. the USA) specifically for transport fuels.

Starches in grains and pulses (and even potatoes) are readily converted to glucose and then fermented to produce ethanol. Sugars may be extracted directly from crops such as sugar cane, sugar beet etc. The majority of ethanol currently produced in Australia is from wheat by-products (EECA, 2006). Sugar cane is expected to become more widely used in Australia for ethanol production, but does not grow well in New Zealand. Root crops, such as sugar beet, are readily grown in most areas of New Zealand and extraction of the sugar is straightforward.

Cellulose, which is the major component of wood, straw, corn stover etc, may also be converted to pentose sugars by hydrolysis. Much of the early work on the hydrolysis of woody-biomass relied on cooking at high temperature and pressure with a dilute mineral acid. This relatively energy-intensive process has been partially replaced by enzymatic hydrolysis, which requires expensive enzymes but takes place under less stringent conditions.



Dilute sugar solutions are fermented using typical brewery technology to produce ethanol. The dilute ethanol solution is usually concentrated to around 94% by distillation. Ethanol must have a very low moisture content if it is to be used for blending with petrol and it is therefore distilled again with a ternary component to produce fuel-grade ethanol

The distillation stage is very energy-intensive and several processes, including membrane separations, are under development.

Bioethanol is the basis of the very large “corn-based” fuel alcohol industry in the US. Blends of up to 20% ethanol in gasoline, known as “gasohol”, are widely available throughout many states.

Methanol

Methanol was originally known as “wood alcohol” as it was obtained by the destructive distillation (similar to pyrolysis) of wood. This process is not used in the manufacture of methanol on an industrial scale. The most common route to methanol is from natural gas via the production of synthesis gas and the catalytic reforming of that to form methanol.

Synthesis gas: $2\text{CH}_4 + \text{H}_2\text{O} + \text{O}_2 = \text{CO}_2 + \text{CO} + 3\text{H}_2$

Gas shift: $\text{CO}_2 + \text{H}_2 = \text{CO} + \text{H}_2\text{O}$

Methanol synthesis: $2\text{H}_2 + \text{CO} = \text{CH}_3\text{OH}$

Synthesis gas may be produced by the combustion of almost any biomass under appropriate conditions. Clean woody-biomass is very well suited to the production of synthesis gas as it has a very low ash content.

Methanol is not proposed as a transport fuel for New Zealand (EECA, 2006), despite extensive transport fleet trials of methanol-fuelled vehicles in the 1980’s, but is a necessary component in the manufacture of biodiesel.

Pyrolysis Oil

Many forms of biomass will produce a mixture of hydrocarbon-based liquids and gases when pyrolysed, *i.e.* heated to high temperatures under oxygen-starved conditions. The resulting liquid may be further refined and separated to provide a range of potentially useful streams including fuels, solvents *etc.* The technologies require relatively severe processing conditions, and are at an early stage of development relative to the process routes identified above, and are not discussed further.

Biogas

Biogas is generated as almost any biomass is broken down by biological processes.

SINCLAIR KNIGHT MERZ



4.5.2.2 Electricity generation

The generation of electrical energy from biomass is widely practised around the world and the technologies and economics are well understood. Biomass – typically woodwaste, bagasse or straw – is burned to generate steam which is used to power an electrical generator. The combustors range from simple “dutch ovens”, through reciprocating and vibrating grates, to bubbling and circulating fluid bed boilers. Biomass is also increasingly co-fired with coal in stoker and pulverised-fuel boilers.

The largest-scale example in the Waikato region is at the Carter Holt Harvey pulp and paper mill at Kinleith, where approximately 200,000 t/year of woodwaste is burned in a specially-designed boiler to produce high pressure steam. Most of the HP steam is passed through a back-pressure turbine, generating up to 40 MWe of electricity.

4.5.3 Summary of Resource Potential

Overall, there is potential for production of both transport fuels and energy from biomass in Waikato Region. This comprises about 20 million litres of ethanol per year for transport fuel from grain crops currently grown in the region. In addition, about 400 million litres per year of ethanol or 800 GWh/year of electrical energy could be derived from woody biomass from low-grade forestry.

4.6 Geothermal

4.6.1 Power Generation

The Waikato region contains most of New Zealand’s high temperature (>150°C) geothermal systems, plus a number of low temperature systems. ***Geothermal is already a significant energy resource, with over 90% of the nation’s geothermal power generation occurring in the Waikato Region.*** Four of the high temperature systems (Wairakei, Ohaaki, Mokai and Rotokawa) are already used for power generation, and five others can potentially be developed for this purpose (Table 7). Environmental, cultural and/or technical issues mean that the others may never be developed for power generation. In addition to generating electricity, these resources can be used directly for specific purposes.

Environment Waikato has classified the Region’s geothermal systems into five categories:

- **Development** systems are available for development, once the appropriate consents are obtained, including from landowners.
- In **Limited Development** systems, takes that will not damage surface features are allowed. This effectively rules out significant power generation on these fields, since Environment Waikato (2006) states that they “would be adversely affected by large takes”.



- **Research** systems are those where not enough about the system is known to classify it as either development, limited development, or protected. In these systems, only small takes and those undertaken for scientific research into the system are allowed. Potentially, with more data, some of the “Research” systems could move into the “Development” or “Limited Development” categories.
- **Protected** systems contain vulnerable geothermal features valued for their cultural and scientific characteristics. Their protected status ensures that their underground geothermal water source cannot be extracted and that the surface features are not damaged by unsuitable land uses.
- **Small** systems are isolated springs or sets of springs. These can only sustain small takes and are not suitable for electricity generation.

This classification of the Region’s geothermal systems gives potential geothermal developers some certainty as to the chances of development proceeding at any one particular geothermal field, while ensuring that other fields are preserved for future generations.

Of the “development” systems, four are already producing electricity, and all could produce more than they are at present, at least in theory.

- **Ohaaki** is resource constrained, in that declining steam production means that the original 116 MW power plant is now producing just 28 MW, though Contact Energy hope to raise this to 50 MW (Contact 2006) with new drilling and by lowering the turbine inlet pressure. It may be possible to extract more energy by adding a binary plant.
- The 165 MW **Wairakei** plant was supplemented in 2005 by a 14.5 MW (net) binary plant. There is potential to add more binary modules, and increase the power generated without increasing the fluid extracted. A new 60 MW development is under way by the Geotherm Group, and Contact Energy intend to increase output by about 25 MW with new pipelines to the Poihipi and Wairakei plants, but major expansion beyond this is unlikely because of environmental issues, particularly subsidence.
- Similarly, development of more than the 20 MW already consented at **Tauhara** is unlikely due to subsidence concerns. No electrical generation is currently occurring there, but steam is being used for direct heat applications.
- Further expansion is possible at **Mokai**, and is likely at **Rotokawa**, where an application for resource consents for another 35 MW has already been filed.
- **Ngatamariki** has existing unused wells, and is likely to be developed for power generation in the future.
- Four wells were drilled at **Mangakino** by Mighty River Power in 2005, though no development plans have been announced. They announced at the 2005 NZ Geothermal



Workshop that exploration had not been as successful as hoped for, so the resource capacity estimate in Table 7 below, which is based on older public information, may be too large.

- **Horohoro** appears to be quite small, and thus will not be a priority for development.

Some electricity production could potentially occur at Atiamuri and Tokaanu-Waihi-Hipaua, but the Limited development classification will preclude any large-scale development. Electricity generation is less likely at Reporoa, which is classed as a Research system, and any potential developer would have to prove that there is no link between Reporoa and Waikite-Waiotapu-Waimangu (Luketina, in prep.). Te Kopia is also listed as a Research system by Environment Waikato (2006), but will be changed to a Protected system now that an appeal against the Research classification by TrustPower has been withdrawn (Luketina, pers. comm.).

4.6.2 Direct Use

Geothermal fluids at temperatures less than 150°C are used in New Zealand for direct heat applications (Figure 16), though if power prices were high enough they could be used for power generation, as in other countries. Major non-electric uses in the Waikato Region are associated with geothermal power plants, and use waste hot water from those power plants. Heat can also be obtained from the low temperature systems, and from systems that are too small or too sensitive for large scale heat or fluid extraction. The low temperature systems are listed in Table 8.

- **Table 7 High temperature geothermal systems in the Waikato Region (from Lawless 2002)**

Geothermal System	Generating Capacity (MWe)	Usable* Installed Capacity (MWe)	Potential Additional Capacity (MWe)	Classification (EW)
Wairakei / Tauhara	880	218	80	Development
Ohaaki	135	28	22	Development
Rotokawa	330	39	159	Development
Mokai	155	96	59	Development
Ngatamariki	190		190	Development
Horohoro	9		9	Development
Mangakino	85		?	Development
Tokaanu-Waihi-Hipaua	220			Limited Development
Atiamuri	18			Limited Development
Reporoa	65			Research
Te Kopia	95			Research**
Horomatangi	380			Protected
Orakei-Korako	150			Protected
Tongariro	105			Protected



Waimangu***	280		Protected
Waiotapu-Waikite	590		Protected
Total:	3690	381	519

* The full installed capacity at Ohaaki and Poihipi plants can not be used due to resource and consent limitations, respectively

** Te Kopia is about to be changed to the Protected category, following the withdrawal of appeals against its Research classification

*** Only a part of the Waimangu system is in the Waikato Region

Horticulture (greenhouse) geothermal heating systems have been developed in many countries, including at Mokai in the Waikato Region. The Mokai operation produces 2,500 tonnes of tomatoes and capsicums per annum in a 5.5 hectare greenhouse that uses both waste heat and CO₂ from the nearby geothermal power plant. Other horticultural uses include orchid growing at Wairakei, a plant nursery at Taupo, and kiwifruit irrigation and frost protection in the Okauia (Matamata) area.

The major geothermally heated **aquaculture** venture in New Zealand is the Wairakei prawn farm, which uses waste hot water from the Wairakei power plant.

The entire temperature range of geothermal fluids can be exploited in **industrial applications**. The major use in the Waikato region is timber drying (Tauhara, Ohaaki), but there are many other potential applications.

Geothermal **space heating** is common within the areas of Taupo and Tokaanu that overlie hot ground at shallow depths. In these areas, shallow wells supply hot water or steam, or use downhole heat exchangers to provide heating for individual homes and businesses. In other parts of the world (e.g. Iceland), a district like Taupo would have a district heating scheme, whereby a few larger wells would provide heating for all homes and businesses in the district.

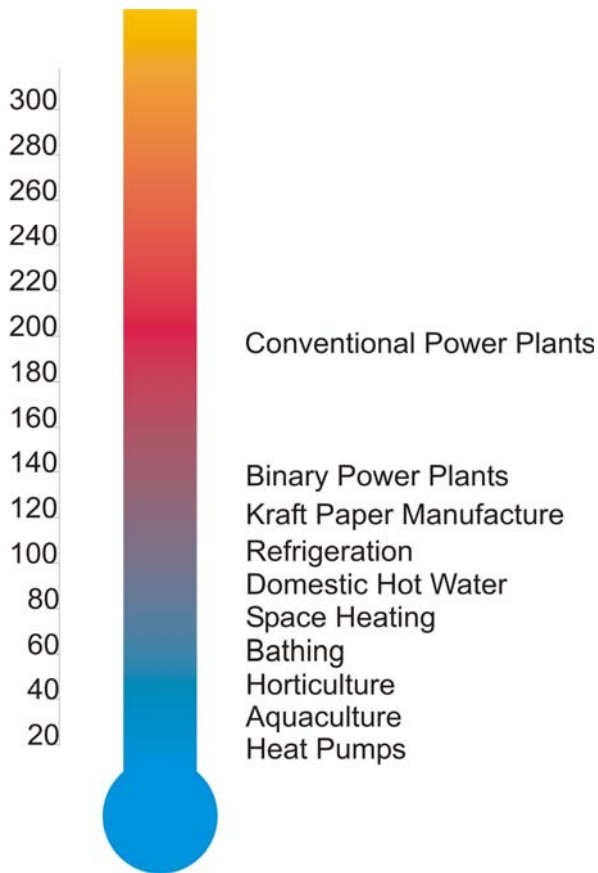

■ **Figure 16 Temperatures (°C) required for some direct use geothermal applications**



■ **Table 8 Low temperature geothermal systems in the Waikato Region (from Mongillo & Clelland 1984, Luketina in prep, and unpublished data)**

System	Flow (l/s)	Max. T. (°C)	Notes
Hamilton	11	27	Wells drilled to about 135 m, supplies heat pump
Frankton			Aberfoyle St, Hamilton
Horotiu			"warm springs"
Kaimai tunnel			Hot water flows out of the Kaimai rail tunnel: not scientifically investigated
Kawhia (Te Puia)		53	Springs on beach
Kerepehi		57	Several shallow wells (~50 m); former springs have been infilled or drained
Lake Waikare		35	On small islet in Lake Waikare, north of Huntly, 70°C in drillhole
Manawaru		58	West of Morrinsville
Mangata (Mangatawhiri)			Hot water encountered in coal exploration drillhole
Miranda	>7	56	64°C in drillhole
Motuoapa			"warm spring"
Ngakuru			no hot water in springs or wells, just a resistivity anomaly
Ngatea	1	30	Artesian flow from well
Ohinewai		23	On flat farmland 300 m E of SH 1, 3.5 km N of Ohinewai
Okauia	1.5	47	On Waihou R., 6 km ENE of Matamata and in golf course. Two wells drilled
Okoroire	56	43	Near Okoroire Hotel, about 16.5 km SSE of Matamata, used for bathing
Okoroire South		36	E bank of Waihou River, 1.4 km south of Okoroire
Orini			
Onemana			Warm water found in shallow well
Orua (Hot Water Beach)	<2	63	Two wells drilled, springs on beach
Puriri	<1	17	Near SH26, south of Kopu
Ranui			
Ruapehu crater		50	Acid, on an active volcano, and within a national park
Sheehan Springs	100	23	3 km north of Waiteariki Hot Springs
Taihoa		44	West bank of Waihou River, 6.4 km SSE of Matamata
Taputapu		49	Buffalo Beach, Mercury Bay, Coromandel
Te Aroha	0.9	59	Springs at the foot of the west flank of Mt Te Aroha, 85°C in drillhole, for bathing
Te Maire (Naike)	10	93	Two or three springs beside Te Maire Stream, 19 Km WNW of Huntly, 52 - 93°C
Totara			
Waikorea	0.04	54	NW of Waingaro, near tributary of Waikorea Stream
Waingaro	5.7	54	13 km WSW of Ngaruawahia, near Waingaro River, used for bathing
Waiteariki		35	Graveson Rd, 12 km NE of Matamata adjacent to Till Rd
Waitetoko			"warm spring" near Waitetoko, on the SE shore of Lake Taupo
Waitoa	2	77	Waitoa River bank, Hapai Rd, Elstow (Suisted Property)
Walton	2	32	4.6 km west of Waharoa on Scherers Rd
Whakamaru Hot Beach		92	Possibly an outflow from Mangakino or Mokai
Whangairorohea		56	Warm water also encountered in shallow groundwater wells
Whitianga	5	53	2006: a well on Cook Drive produces 5 litres/second
Wigmore (Hahei)		27	5 km north of Hot Water Beach, springs not found recently; one well present



Elsewhere in the world, **ground source heat pumps** have become widely used since the 1980s. Heat pumps permit the extraction of heat from warm ground or groundwater, in a similar way to standard air conditioning, only instead of using ambient air for the heat source (or sink), warm ground or groundwater is used. Ground source heat pumps are much more efficient than standard air conditioning units because in winter, when heating is required, the ground is warmer than the air (even away from thermal areas), and in summer, when cooling is required, the ground is often cooler. The only energy required is that needed to pump the circulating fluid through the system. This technology is used on a large scale in North America and Europe where the climate, high electricity prices and subsidies make this technology economic. These drivers are largely absent in New Zealand and as a result there has been little uptake of the technology here. A heat pump (heating and cooling) system has been operating at the Rural Bank and Finance Corporation Building in Hamilton for many years, using 27°C groundwater (Mongillo & Clelland 1984).

All other factors being equal, GSHP's are most cost effective in areas with climatic extremes (cold winters and hot summers) because the pump provides both heating and cooling and is used for longer periods and at high rates. As a result, the capital investment can be recovered in a relatively short time.

Thain *et al.* (2006) provide estimates of annual costs for space heating and assisted water heating using GSHP in New Zealand. For a typical household with an electricity price of 12c/kWh, and space heating for 800 hours per year, the annual heating cost (space and water) is \$520 compared to \$1320 for electricity alone, i.e. a saving of \$800 per year (~60%). However, this is not a sufficiently high saving to compensate for the initial high capital cost (about \$12,000). On this basis, it is unlikely that GSHP's will find favour for domestic heating in the Waikato region, particularly if natural gas is available.

For larger commercial buildings which often require heating and air-conditioning, economies of scale may make GSHP's economic, particularly where there is a source of water to improve efficiencies (e.g.: river-side developments).

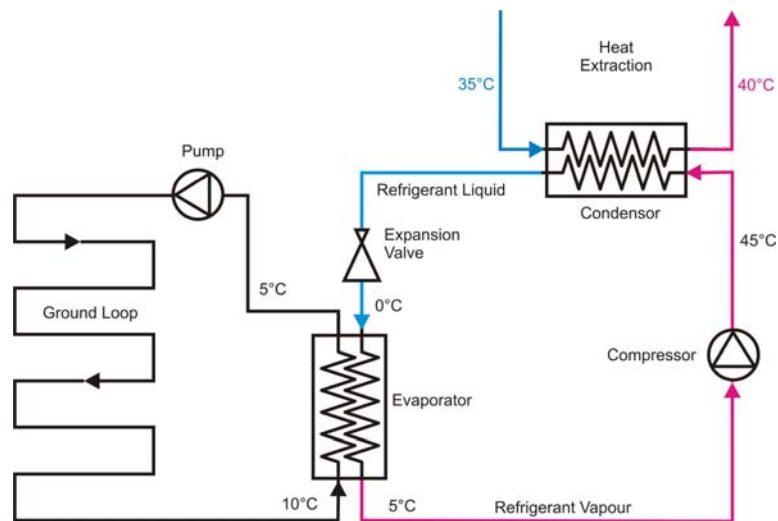
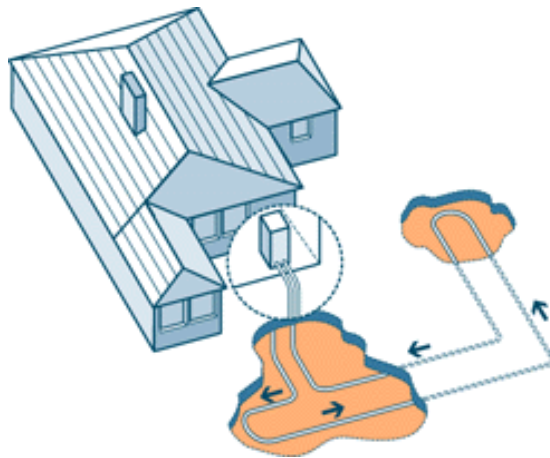

■ **Figure 17 Schematics of a ground source heat pump system.**

By far the most widespread use of low temperature geothermal resources in New Zealand is for **bathing**. Hot baths and spa complexes have been developed at many of the high and low temperature systems throughout the country.



4.6.3 Summary of Resource Potential

Existing geothermal power plants within the Waikato Region generate about 380 MWe. The available undeveloped geothermal resource (taking regulatory constraints into account) is 1.5 times as great, with additional electrical generation capacity estimated at about 520 MWe, particularly at Ngatamariki (190 MW) and Rotokawa (159 MW) geothermal systems. Smaller potential exists at Wairakei / Tauhara, Mokai, Ohaaki, and Horohoro. *The potential for direct use applications is large*, particularly if ground source heat pumps are considered, as these can be used throughout virtually the entire region, and not just in thermal areas.

4.7 Marine

4.7.1 Tidal Resource

Tides are the periodic rise and fall of large bodies of water caused by the gravitational attraction of the sun and moon. Since the earth is rotating, two tide cycles occur each day. At periodic 28 day intervals, the alignment of the moon, sun and earth causes an additive effect, creating stronger tides and conversely at other times, weaker tides. Localised bathymetry concentrates tidal flows in certain regions into areas of highly energetic activity.

A number of factors come into play when estimating and assessing the extent of the resource and its 'harvestability'. These can be grouped into two categories: 'site' and 'technology'. Site assumptions are focussed around the extent of the resource itself while the technology group is focussed around the technical issues of harnessing the resource. A critical decision in determining the extent of the resource is based around estimating the flow velocity and its variability dependant upon the lunar cycle. As a complete set of detailed data for every site of potential interest is seldom available, certain assumptions or extrapolations must be made.

Typically these will concentrate upon;

- Influence of the boundary layers on flow rates (both seabed and channel sides) and the effect they have on flow through the channel cross section between 'mean peak spring velocities' and 'neap' flows (Figure 18)
- Variance of flow within tidal 'ebb' and 'flood'
- Presence of bathymetry oddities that cause 'hot' and 'cold' spots
- Thresholds of energy extraction beyond which tidal flow pattern will change in response to the extraction itself (*i.e.* channel blockage effects)

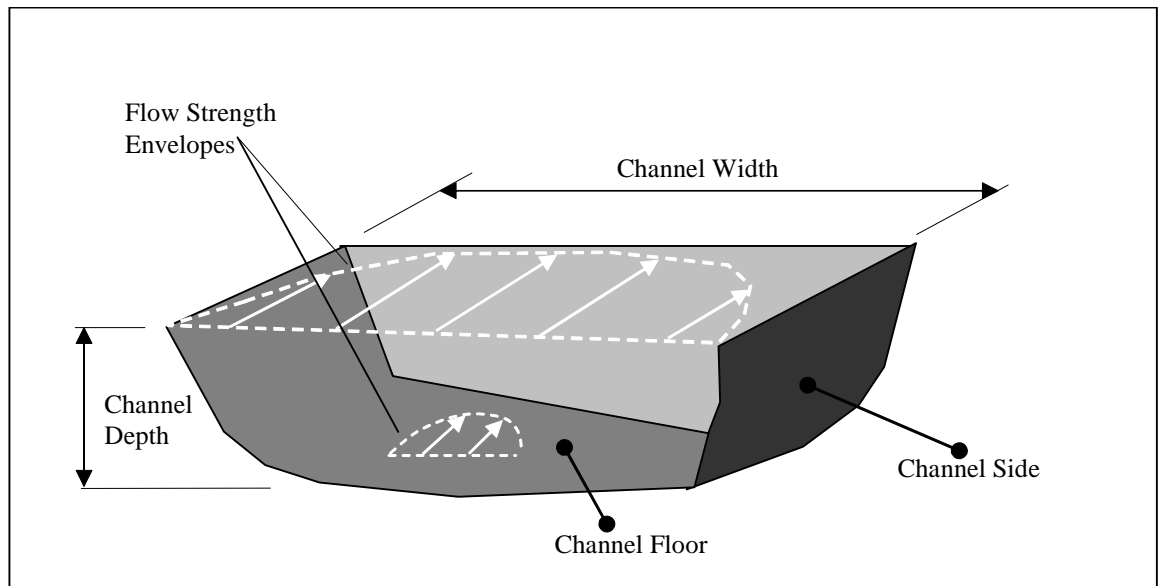

■ **Figure 18 Cross sectional view of tidal channel**

Factors influencing ‘harvestability’ are largely technology dependant:

- Efficiency of devices to capture energy and convert it to electrical power (Figure 19). As devices operate in flow environments that are far from constant, design compromises result in the device being designed to only operate across a selected range of conditions. Typically the device will have a ‘start up’ flow velocity, below which it does not operate, and a ‘rated power’ beyond which it does not operate. Below the cut in and above the rated power, the device will ‘shed’ power.
- Reliability of the device and the speed with which repairs can be executed
- The density of device deployment or spacing within an array
- The location of the device relative to boundary layers
- The transmission efficiency of the electrical connection relative both to land and the end user proximity
- Needs of other maritime users

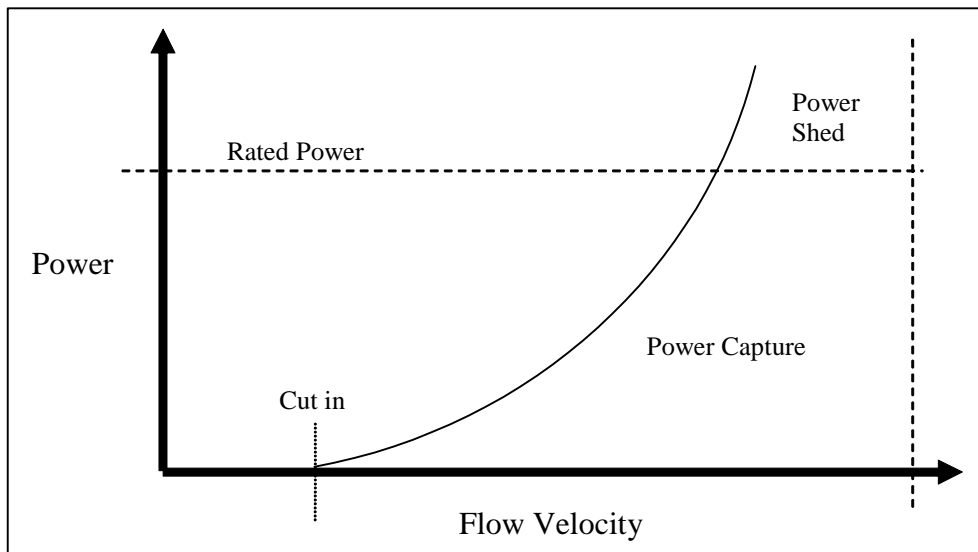

■ **Figure 19 Generic device power capture graph**

The tidal range in New Zealand is low (2 to 3 m) compared to many other places around the world (up to 10 m in the UK). Nevertheless there are some sites around New Zealand with significant tidal currents. Most promising are the areas around headlands, together with Cook and Foveaux Straits and the entrances of some natural harbours. Maritime tidal atlases suggest that the maximum tidal current in those harbour entrances is approximately 2-3 m/s.

The tidal harbour areas of Raglan, Aotea and Kawhia are within the Waikato region. The information available regarding tidal flow patterns at these sites is limited. This makes accurate prediction of the extent of the tidal energy resource problematic, and the estimates provided should only be taken as indicative and used in a cautionary fashion.

Raglan

The published hydrographical map of the Raglan harbour area (RNZN NZ4421) provides information regarding the plan view outline of the harbour and its water depths (given as a combination of contour and point measurements). Additionally at specific point locations, 'Tide Diamonds' provide data about spring and neap flow rates for 6 hours either side of high water. The tidal power at these points may be determined by summing up the power calculated at hourly increments. Using a simplifying assumption that two tidal cycles occur every day, multiplying by the number of days per year and by the estimated water depth at that point, the annual power per unit width is found. This process was applied to Diamond 'A' which is located 0.75km from the harbour mouth in water around 2.8m deep and Diamond 'B' which is located 3.6km from the mouth in around 5m of water (adjacent to Raglan Wharf). Assuming that the flow rates are true for



the upper 80% of the water column, the total annual power resources were calculated as 14.16 MWh/ unit width and 6.24 MWh/ unit width, respectively. However, the detail involved in these calculations is not as useful for understanding the more general flow characteristics of the harbour as the level of detail suggests. The most informative calculation of the resource is to consider the power flux of an entire cross sectional area. In order to achieve this, detail is required, not only about the cross section shape (in terms of width and depth distribution), but also about the flow rates both across and through the section. This information is not available, and unfortunately can not be extrapolated from the Diamonds. Additionally both of the Diamond sites are in relatively shallow waters which are not well suited to most tidal energy extraction technologies.

UK Royal Navy Admiralty notes state that the tidal stream rates in the vicinity of the harbour entrance are around 4 knots, and flow ranges from 1.5 to 2 knots inside the harbour. A combination of this Admiralty information with data from NZ4421 provides a power estimate. NZ4421 shows that 10m water depth exists across a span of 110m in the vicinity of the harbour mouth. Assuming the upper 80% of this channel cross section flows at above 2 knots 30% of the time, the sectional total annual power resource is calculated as 1287 MWh.

Aotea

No RNZN hydrographical map of Aotea harbour area has been published. However, the UK Royal Navy Admiralty notes state that tidal stream rates in the vicinity of the harbour entrance range from 3 to 5 knots and from 2 to 4 knots in the anchorage area of the harbour. Assuming that the water depth of 5m stretches a span of 150m within the vicinity of the harbour mouth, and that a flow velocity exceeding 2.5 knots is available 30% of the time across this entire cross section, and at that the flow rate is constant for the upper 80%, the sectional total annual power resource is calculated as 1714 MWh. The absence of hydrographical data means that of all the tidal power estimates in this report, this is the most speculative.

Kawhia

The published hydrographical map of the Kawhia harbour area (RNZN NZ4423) provides an indication of the maximum velocity reached in the mouth of the harbour between the Tauatahi and Opapaka points (stated as 3 knots). In addition, UK Royal Navy Admiralty notes state that tidal flow rates in the vicinity of the harbour entrance range from 3 to 5 knots and from 1 to 3 knots inside the harbour. NZ4423 shows a water depth of greater than 20m across an 80m span within the harbour mouth, which itself is around 0.5km wide. If it is assumed that within the vicinity of the harbour mouth the flow velocity exceeds 2.5 knots 30% of the time, and at that this flow rate is constant for the upper 80% of the water column, the total annual power found within the harbour mouths deepest section is calculated as 3658 MWh. This is not the total power flowing in and out of the mouth, rather an indication of the power within a relatively narrow section of its depth.



Whilst this therefore understates the power, it indicates the power availability within the area where tidal energy extraction devices would be most likely to be placed.

Generation capacity

Most tidal power technologies presently being developed are designed for water depths deeper than those available within the 3 harbours and are also predicted to be economic in locations where the flow rates exceed those found within the 3 harbours. For example, Marine Current Turbines require water depths of between 25-35 m. There might be some future developments that can be used in shallow water (10-25m), which would be applicable to Kawhia, but they are likely to need higher flow rates (above 5 knots).

Raglan and Aotea Harbours are not well suited to tidal power generation. Kawhia harbour is better suited due to its deeper waters, but would not be considered economic in the near future.

However, future generations of tidal devices might change this. Capacity would be in the megawatt range for Kawhia.

4.7.2 Wave Resource

Ocean waves are created by the conversion of kinetic wind energy acting across the surface of an area of open water, where the energy within the wind acts upon the surface friction of the water such that with time it creates an orbital water particle motion. The open space expanse over which the wind and water have opportunity to interact is referred to as the fetch. The interaction between the wind and sea is such that the energy transfer between the mediums will continue until such a point that either equilibrium is reached (this is known as a fully developed sea) or that the fetch length is such that the waves enter shallow waters and break. Wave energy additionally has a directionality component related to the wind direction driving the fetch.

As wave energy propagates nearer to coastal regions, it experiences several physical changes whose additive effect is to reduce the levels of energy resource found in shallow coastal waters as compared to their deep water ocean counterparts. The driving factor in this transformation is water depth. As deep water waves enter coastal waters (deep water is where the water depth is greater than half the wave length), a transition in the wave characteristics occurs. Whilst the wave frequency remains the same, three factors change:

- The wave length shortens
- The wave amplitude increases
- The wave velocity reduces

The above changes are underpinned by the fundamental mode change of the wave's water particle velocity path from circular to elliptical. This is caused by the influence of the seabed and its



friction acting upon the wave propagation. At a point where the wave has grown in height by around 1.3 times, its steepness will be such that it topples over and can be visually seen as surf.

As with the tidal case study, the estimates of both the total and attainable wave resource are based upon a set of assumptions that significantly impact the overall results. These assumptions are summarised:

- Distance to land mass for grid connection
- Single device capture efficiency
- Device availability
- Device spacing within array
- Transmission efficiency
- Minimum allowable site area
- Site survey data
- Needs and rights of other maritime users

Many of the above are directly analogous with the tidal situation. However wave device power capture efficiency is somewhat different. Unlike tidal, where the dominant variable in the power calculation is velocity, with waves, power capture is a combination of wave period and height (Figure 20), thus creating a 3-D scenario. Typically a device will be designed such that below a certain threshold or ‘cut in’ the device will shed power. Above a certain threshold associated with its rated power, the device will also shed power, and in high energetic storm conditions the device may shed power as a survivability strategy.

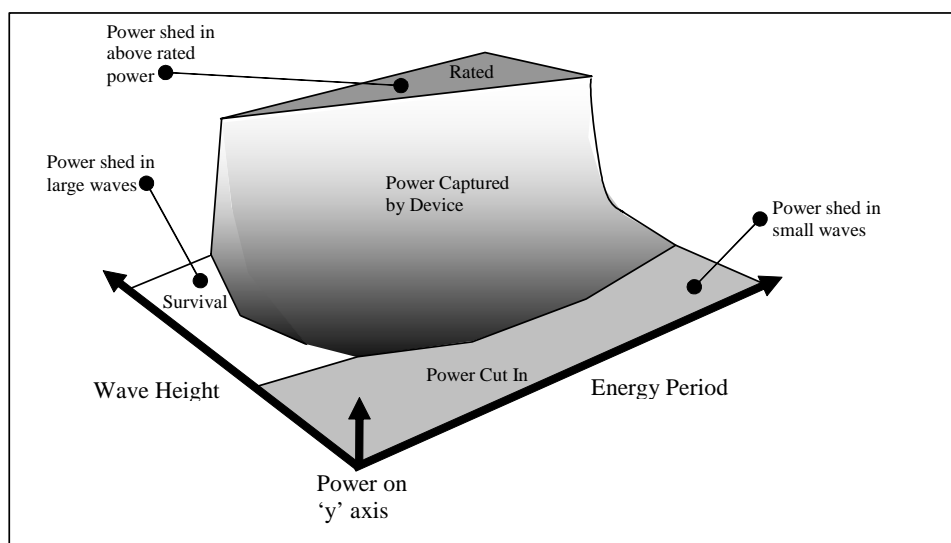

■ **Figure 20 Typical wave device power capture**



In New Zealand, the weather systems that are driven up from the southern ocean play a major influencing role. It follows that offshore and coastal regions exposed to these influences will contain a greater abundance of wave energy than more sheltered areas. Accordingly, reports show that the annual average wave power around the New Zealand coast varies from 8 kW/m at East Cape to 99 kW/m near Stewart Island. A typical value is around 30 kW/m, which is favourable in terms of global energy potential. Figure 21 shows average significant wave height for coastal areas of New Zealand for the period 1979-93. The presentation is given in terms of ‘Significant Wave Height’ (a simple statistical tool of averaging the height of the highest one third of the waves in a given sea state). As a guide, areas with greater significant wave height have better potential for wave power electricity generation.

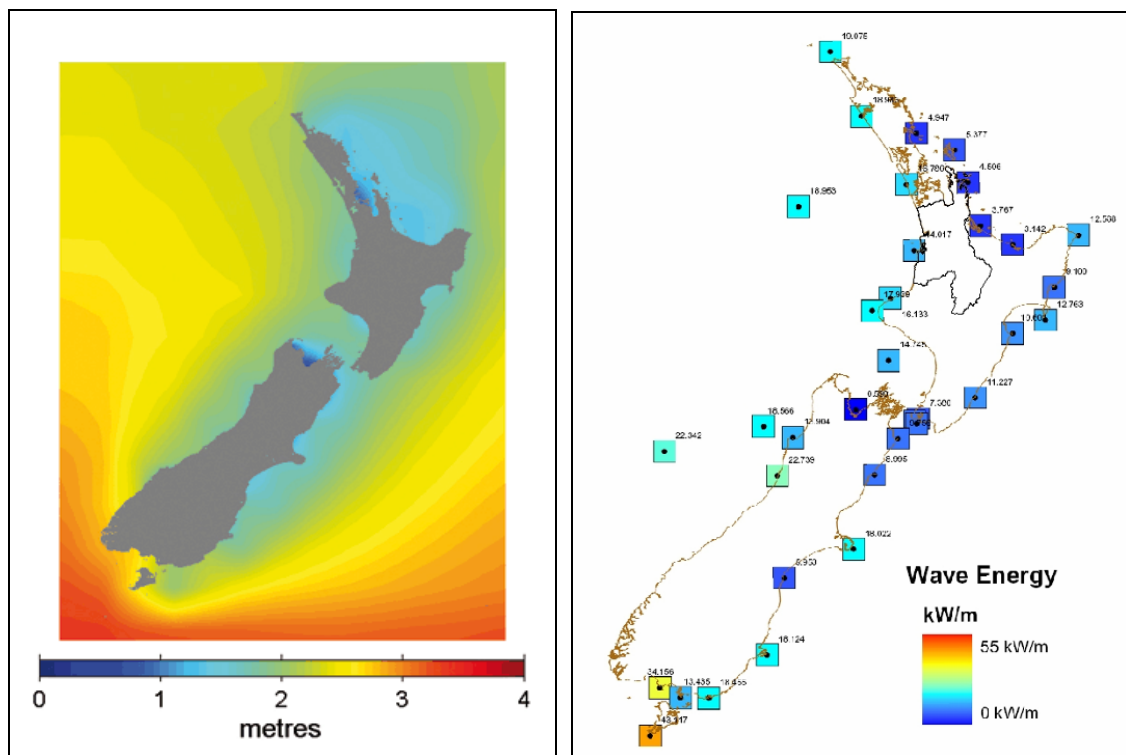

■ **Figure 21 Mean wave height from 1979 to 1998 and wave energy (NIWA 2006d, East Harbour Management Services 2005)**

Another study provides an annualised average wave energy atlas for selected locations around the New Zealand coastline and offshore deep waters (Figure 21). This information is provided in kW/m. Relative to the Waikato region, data is provided 262 km due west of the Waikato / Auckland border. This information states that potential power levels of 19kW/m are available and



it may be assumed that the vast majority of this energy potential will still be available at the 50m depth contour. This depth occurrence varies between 5km and 20km offshore along the Waikato coastline (see Figure 22). A wave farm 20km from a shoreline connection point will have a very significant electrical cabling connection cost burden. This can be overcome by locating the farm nearer to the shore, but a trade-off exists as energy resource availability will decrease in shallower (<50m) water depths.

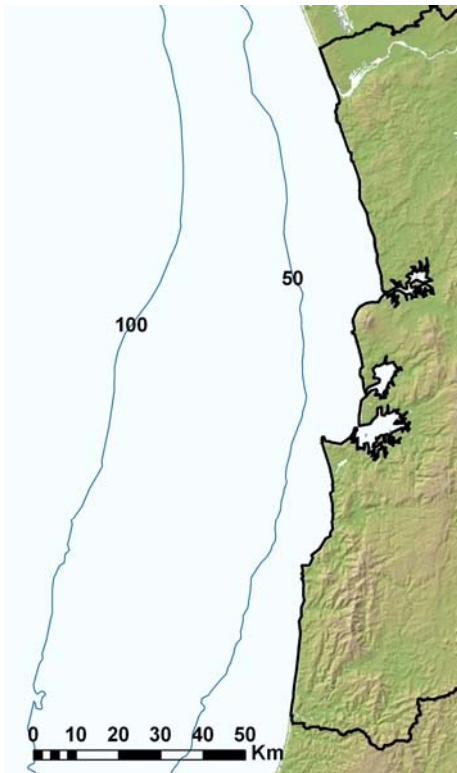

■ **Figure 22 Water depth contours along the Waikato coastline (depths in metres)**

To illustrate the attainable power potential, a simple case study based upon resource potential and assuming attenuator technology may be considered to demonstrate the wave power extraction viability. Operating in the 19kW/m wave climate, each unit would produce around 250kW (significant wave height 2.5m and wave period of 8 seconds) and spacing the units 150m apart, a farm array of 14 devices would occupy a footprint of 2100m by 150m. Assuming a load factor of 40%, the annual energy production per unit would be 876MWhr which approximates to 1.226GWhr per farm.

Based on these numbers it is estimated that about 10 MW/km² of wave energy devices could be installed. With a coastline length of around 170 km, this equates to a capacity potential from wave energy in the thousand megawatt range, ignoring environmental constraints and conflicts with other maritime users.



5. Enabling Assistance

5.1 Introduction

Although the focus of the current study has been to assess renewable energy resources and regulatory approaches at the regional level, there are a variety of non-regulatory methods (referred to here as ‘enabling assistance’) which could also be developed to encourage greater renewables uptake. This chapter presents a number of such approaches for consideration by councils, particularly for those regions where there is a clear and pressing energy issue such as those outlined in Section 2.6.

5.2 Renewable Energy Expertise

Renewable energy can be viewed as a development activity with potentially adverse local environmental impacts but with national energy benefits (*e.g.* security of supply) and international environmental benefits (*e.g.* climate change). As such, the inclusion of renewable energy in the Resource Management Act (RMA) needs to be recognised as a departure from the norm for councils who have primarily been responsible for managing regional environmental resources. At the same time, the inclusion of renewable energy in the RMA is consistent with the councils’ role in the meeting of national and international objectives on issues such as biodiversity.

As such, with a number of notable exceptions, the majority of councils have limited in-house expertise on issues relating to energy and renewable energy. This is perhaps unsurprising given councils’ core functions under the RMA, the relatively recent inclusion of renewable energy in the RMA and the rapid development in renewable energy technologies. However, it is clear that if the councils are to play a role in the greater uptake of renewables through either regulatory or non-regulatory approaches, then additional expertise is required. This should be such that a council’s capacity with regard to renewable energy is commensurate with that of its other functions, *e.g.* soil conservation or water quality. This would assist the high-level resolution of how proposed renewable energy developments might affect aspects of the regional environment.

Whilst the requirements for renewable energy expertise will vary between councils, it will largely be determined by the region’s and council’s aspirations and the renewable resources available in the region.

5.3 Renewable Energy Plans / Strategies

The urgency and type of energy issues varies substantially between regions. For those regions with one or more pressing energy issues, such as those outlined in Section 2.6, councils may wish to consider the development of an energy plan / strategy. This would typically be positioned as an economic development or infrastructure plan / strategy rather than an implementation mechanism under the RMA. Such an approach would provide for design flexibility, speed of implementation



and the ability to consider wider, non-renewable energy issues. A preliminary indication of this regional approach is provided by the Southland Regional Energy Strategy (2004).

5.4 Resource / Constraint Mapping

The issue of developing spatial representations of renewable energy resources overlaid with information relating to development constraints (*e.g.* outstanding landscapes, areas of high cultural value) was raised at a number of discussions with councils. Whilst Chapter 4 provides an indication of the magnitude and location of renewable energy resources in the region, more detailed information would be required to prepare resource maps of value to regional policy statements and plans. This type of more detailed information is likely to be held by a disparate group of organisations including renewable energy developers, research organisations and regional / district councils. For instance, with regard to wind resources, extensive field studies have been undertaken by developers and historic records are held by meteorological departments. The most detailed and reliable information is commercially sensitive and as such, is unlikely to be made available to councils. However, broad-scale resource maps could be developed in a cost effective manner by combining information held by public institutions with commercially available numeric models or numeric modelling capabilities.

It is to be noted that mapping also presents a potential new constraint to greater renewables uptake in that broad scale resource mapping may overlook small high potential areas. Furthermore, constraint mapping without adequate consultation with the renewable energy sector may inadvertently screen out areas of medium or high potential. As such, decisions on whether and how to develop resource / constraint maps requires careful consideration. Developers also express concern that once detailed resource maps are available, landowners can demand much higher access or “mitigation” fees, presenting a secondary barrier to renewables. Section 6.2.1 provides a further discussion on the identification of suitable sites for renewable energy developments.

5.5 National Renewable Energy Forums

In order to promote good practice on both regulatory methods and enabling assistance and develop a deeper appreciation of the issues associated with renewable energy, a programme of forums involving selected councils from across New Zealand could be established. Alternatively, renewable energy could be brought into existing forums, such as those for the Chief Executives of councils.

5.6 Economic Instruments

RMA financial contributions are to be taken, and used, for a purpose specified in the relevant plan. These could be used to charge a greater contribution to energy generation methods that create the greatest environmental damage. For example non-renewable generation that creates air discharges could be charged on the basis of the volume of type of discharges produced.



The rules providing for such contributions would have to be written into a Plan and would be a requirement on resource consents. There are a number of issues with such financial contributions.

Firstly the process of placing the required rules into a District Plan is complex and may take a considerable effort and time. The environmental effects that the financial contribution relates to will need to be fully justified and defined accurately in terms that can be translated into monetary terms.

There is also a case that can be argued that the environmental effects of emissions are national in nature and reducing such emissions creates national benefits. It may therefore be that any economic instruments are better justified at a national level rather than at the local level.

Other economic instruments such as carbon taxes, tax incentives for renewable energy projects and variable electricity pricing (giving advantages to renewable energy) are not available to councils and will rely on Central Government implementation. Councils may have an advocacy role in respect of these matters.



6. Regulatory Approaches

6.1 Current Regulatory Approaches

The main regional policy and regulatory document in the Waikato Region is the Waikato Policy Statement. The policy statement was made operative on 1 October 2000. The RPS contains a small section on energy. The main policy thrust in this section is based around energy efficiency and conservation. The implementation methods listed do not include any regulatory approaches but include for example;

- 2) *Encourage the use of alternative and renewable energy sources through community education.*

The Regional Policy Statement contains a comprehensive section on the geothermal resource. This defines geothermal as a renewable resource under certain circumstances. It sets out which parts of the Region's geothermal resource are able to be used and which parts should not be used. This section is also reflected in the Regional Plan (see below). The geothermal sections are under appeal, and not yet operative.

The Council is proposing to review its Regional Policy Statement in 2009/2010. In planning for this review the Council has stated that the RPS will have an energy section that will deal specifically with renewable energy resources in the Region to a greater extent than the current RPS.

Other statutory plans for the Waikato Region under the Resource Management Act include a Regional Plan and a Coastal Plan. The Regional Plan is an integrated plan that addresses the Council's responsibilities on land including air and water discharges, the use of lakes and rivers and the taking of water including geothermal water. This Plan was notified in 1998 and is currently the subject of a number of appeals. The Coastal Plan applies across the Coastal Marine Area of the Waikato Region from the line of Mean High Water Spring out to 12 nautical miles. The Plan was made operative in 2005.

Apart from the geothermal resource, these plans do not specifically address renewable energy in any significant way.

Within the Waikato Region, the various Districts have varying approaches to energy:

- Taupo District Council is currently developing the Taupo Growth Management Strategy, which will address energy in that
 - (a) the district is a net exporter of energy



(b) the identification for the potential for reverse sensitivity particularly with geothermal fields and

(c) identification of potential for secondary use of geothermal energy (*e.g.* heating of glass houses).

- Hamilton City Council has developed a set of comprehensive policies and number of initiatives in renewable energy and community and Council energy efficiency.
- Matamata Piako District Council, Hauraki District Council, Otorohanga District Council and Waitomo District Council appear to currently have no electricity or energy policies in place.
- Franklin District Council is a signatory to the NZ Urban Design Protocol, where improved design includes efficient energy use. It also has specific rules in its District Plan allowing low level solar and wind generation as a permitted activity.
- The Waikato District Council has a specific section in its District Plan concerning energy and including policies on energy efficiency and subdivision design. It also contains policies recognising the positive benefits of renewable energy.
- The South Waikato and Waipa Districts both have specific zones providing for existing hydro stations.
- The Thames-Coromandel District Council Community Outcomes Statement includes a reference to the development of innovative energy systems.
- The Rotorua District Council has a Waste Management Strategy that points to the possibility of Waste to Energy projects in the future. Its District Plan makes specific provision for renewable electricity generation as a Discretionary Activity.

6.2 Potential Regulatory Approaches

The following policy suggestions examine some ideas concerning how Environment Waikato may be able to provide for renewable energy use and generation through its Regional Policy Statement and Regional Plans.

6.2.1 Identification of Suitable Renewable Energy Locations

Regional Policy Statements and Plans can assist the provision of renewable energy by identifying the potential locations where forms of renewable energy generation that have specific locational constraints may be appropriately located. Resources that have potential locations that can be identified typically include wind-power sites, hydro, geothermal and marine based energy sources. These locations can be illustrated on maps within the Policy Statement or Regional Plan.

The development of this mapping should include the identification of any potential environmental effects that may limit or preclude the use of the resource in terms of sustainable management of



natural and physical resources. For example, some areas suitable for wind generation may also be in areas of outstanding landscape value. Some rivers that may be able to be used for hydro electricity generation may have high environmental values that would preclude such development.

An alternative to mapping areas with particular energy potential (where this is not possible or desirable) is to identify broader natural area classifications where particular types of energy development is appropriate and provide for more permissive rules for development within those areas.

Following the 2005 amendments to the RMA, Regional Policy Statements can where appropriate direct District Plans to make suitable provision for the development of renewable energy in locations identified in such mapping. Alternatively the mapping can be used to give policy direction to resource consent processing at both regional and district levels. The maps can also be used to develop appropriate rule packages in the council's own Regional Plans concerning the use and taking of water and the coast etc.

While such locational based policy development has not to date been used extensively in Regional Policy Statements and Plans the approach is valid and is starting to be used more frequently. For example the Auckland Regional Policy Statement details the Metropolitan Urban Limits on a map. A mapping approach is also enabled via the 2004 amendment to the Resource Management Act that enabled the establishment of aquaculture management areas. A similar approach is also taken in the geothermal chapter of the Environment Waikato Policy Statement.

Recommendations

- (i) That where possible the Regional Policy Statement identify areas within the region suitable for renewable energy development including wind, hydro, geothermal and marine based generation. The location of these areas should be developed taking into account the potential effects of such generation facilities and the sustainable management of natural and physical resources.
- (ii) That District Plans should be amended to ensure that rules do not preclude renewable energy development in areas identified in the Regional Policy Statement. (For example landscape protection areas should not identify areas deemed suitable for wind power generation in the Regional Policy Statement.)
- (iii) That Regional Plans and District Plans provide for existing renewable energy generation facilities. For example specific zones may be provided for existing hydro stations.



6.2.2 Non-Locational Policy Development

Some renewable resources are not locationally constrained or there may be insufficient information about a resource and its effects available to develop a locational approach (*e.g.* biomass generation).

Regional Policy Statements and Plans can assist the provision of renewable energy by developing detailed policy on how “trade offs” between various resources can be made. It is considered that this approach is mandated by the changes to the Resource Management Act that requires Councils to have particular regard to the benefits to be derived from the use and development of renewable energy. This approach essentially considers the benefits of renewable energy and looks at various “trade offs” between the local and wider benefits of that development and the localised environmental effects that may result from renewable energy generation and transmission within the context of sustainable management of natural and physical resources. If direction on such decision making is not specified by the council, then it is difficult for Councils to balance the benefits of renewable energy against other environmental effects when considering consent applications. It is considered that these policies need to be as detailed as possible so as to give firm direction.

An example of this approach can be illustrated by policies concerning the provision for wind power. Policies can be developed that would give guidance concerning within which landscapes wind power generation turbines may be appropriately located after having considered the visual effects of wind turbines.

Recommendations

- (i) That the Regional Policy Statement include a series of objectives and policies outlining how “trade offs” between localised effects and the benefits of renewable energy should be made.
- (ii) That District Plans be amended to give effect to the Objectives and Policies developed in (i) above.

6.2.3 Consents

Discussions with industry players have indicated that consenting issues are a significant disincentive to the development of some forms of renewable energy. There are a number of consenting options that councils can investigate that would provide encouragement for the development of renewable energy.

Ways in which consenting can be modified include the use of incentives within the consenting processes to encourage the use of renewable energy. Incentives could include:



- greater air discharge thresholds for biomass energy generation (where this can be supported by appropriate ambient air quality), or
- reduced consent thresholds (types) when based on renewable resources, or
- longer consent periods before consent renewal for use of renewable resources than for non-renewable resources.

Codes of practice for renewable generation can be used within consenting processes. Such an approach requires the development of codes of practice, and compliance with these will be accepted instead of the need to comply with rules, or alternatively result in simpler forms of resource consent where compliance with the code of practice is achieved. This technique is reasonably common in Resource Management Act plans with some other issues. Regional Energy Strategies and Regional Energy Forums may be suitable avenues for developing codes of practice around a number of renewable energy resources. These will likely need development in association with generators, District Councils and other interested parties.

Recommendations

- (i) That Regional Plan rules be amended to provide greater air discharge thresholds for biomass energy generation where this can be supported by ambient air quality.
- (ii) That Regional Plan rules be amended to reduce consent thresholds for energy generation based on renewable resources.
- (iii) That Regional Plan rules be amended to provide longer consent periods for renewable energy projects.
- (iv) That the council work with energy generators, District Councils, Tangata Whenua and other interested bodies to develop industry codes of practice for renewable energy production.

6.2.4 Domestic or Small Scale Developments

The scale of potential renewable energy projects may also be considered by Councils in setting policy, consents thresholds and notification requirements within plans. In some cases it may be just as difficult to obtain consent for a small scale project that has a low level of local environmental effects as for a large renewable energy project, as plans do not always make distinctions between small and large scale effects. This tends to encourage large scale projects that may have more significant effects than a series of smaller scale projects.

For example, small scale hydro generation projects that do not use dams or do not divert significant volumes of water could be rendered subject to lower consent thresholds than large projects. For example, a wind farm with only one or two turbines will have less visual effects than a large wind



farm, yet often a similar consent process is required for both. This situation could be changed by setting scale thresholds for resource consents whereby smaller scale projects are made subject to controlled or restricted discretionary activity consents whereas larger scale projects require fully discretionary resource consents. Domestic scale generation may be able to be a permitted activity.

At the District level for example, Franklin District Council makes specific provision for some small scale renewable energy generation as permitted activities in rural areas.

Recommendations

- (i) That the Regional Policy Statement, Regional Plans and subsequently District Plans be amended to make appropriate provision for various scale energy generation facilities.
- (ii) That the Regional Policy Statement, Regional Plans and subsequently District Plans be amended to allow small scale renewable energy production (including solar and wind) as permitted activities.
- (iii) That District Plan subdivision rules provide site orientation provisions in order to support solar heating and power generation.
- (iv) That District Plans rules should be amended to ensure that development control rules (*e.g.* maximum height rules) do not unreasonably preclude domestic scale renewable energy production (*e.g.* allows solar panels on roofs) and protect solar access to nearby properties.

6.2.5 District Plans

Section 75(3) of the Resource Management Act requires District Plans to give effect to a Regional Policy Statement. Councils are therefore able to give direction to the types of rules and policies that the constituent District Councils are able to place in District Plans that directly control land use.

Good practice would dictate that this power should be used in conjunction with a collaborative approach to issues with District Council. Councils are well positioned to influence how District Plans in their region provide for renewable energy generation through specific policy direction within Regional Policy Statements. The nature of the energy resources within the region are such that each District has its own unique range of resources. The response of each District is likely to be different based on the nature of resources in each District.



Recommendation

- (i) That the council work closely with the District Councils within the region to ensure that District Plans reflect the renewable energy objectives and policies of the Regional Policy Statement.

6.2.6 Future Proofing Policy Statements and Plans

In developing the next generation of Regional Policy Statements and Plans, Councils should have regard to the potential developments in renewable energy that may occur in the region over the life of the Policy Statement or Plan.

For example, many regions have large areas of coastline that may be suitable for one or more forms of marine electricity generation through the life of a Regional Policy Statement or Regional Coastal Plan. Because this technology is still evolving, polices (and rules in Regional Coastal Plans) could consider how new technologies may be used in the future, what potential environmental effects may result and the circumstances in which such technology may be put in place. In effect polices may be developed in a way that future proofs the policy statement/plan by making provision for new technology to the extent possible under current levels of knowledge.

Recommendations

- (i) That the Regional Policy Statement and Regional Plans be amended to recognise potential future renewable energy technologies and make high level policy provision for such technologies.
- (ii) That the council monitor the state of technology development and make changes to the Regional Policy Statement and Regional Plans to make appropriate provision for developing technologies.



7. References

BRANZ, 2004: Study Report No. SR 133. Energy Use in New Zealand Households – Report on the Year 8 Analysis for the Household Energy End-use Project (HEEP).

Canterprise, 2005: <http://www.windenergy.org.nz/images/050902-Canterprise-WindMap99kb.gif>

CAE 1992: Our waste our responsibility: towards sustainable waste management in New Zealand: project report. University of Canterbury Centre for Advanced Engineering.

Contact, 2006: http://www.mycontact.co.nz/pdf/financial/2006_wairakei_investor_presentation.pdf

Deffeyes, K. S. 2001: Hubbert's Peak: The Impending World Oil Shortage. Princeton University Press, Oxfordshire.

East Harbour Management Services, 2004: Waters of national importance – identification of potential hydroelectric resources. Report prepared for Ministry of Economic Development.

East Harbour Management Services, 2005: Renewable energy industry status report 2nd Edition. Report prepared for EECA. Includes data from NIWA (Frazerhurst).

EECA & CAE, 1996: New and Emerging Renewable Energy Opportunities in New Zealand.

EHMS 2005 reported in: Renewable Energy – Industry Status Report Second Edition, East Harbour Management Services, 2005

East Harbour Management Services, 2005: Availabilities and costs of renewable sources of energy for generating electricity and heat. Report prepared for Ministry of Economic Development.

EECA, 2001a: Review of New Zealand's Wind Energy Potential to 2015, EECA, 2001

EECA, 2001b: Solar Energy Use and Potential in New Zealand, EECA, 2001

EECA, 2004: EECA Energy End Use Database (<http://www.eeca.co.nz/enduse/index.aspx>)

Environment Waikato, 2006: Classifying geothermal systems
(<http://www.ew.govt.nz/enviroinfo/geothermal/classification/index.htm>)

Enconsult 1981: A comparative assessment of the production of transport fuels in New Zealand from coal and biomass. Report produced for the Liquid Fuels Trust Board by En-Consult Technology Limited, June 1981.

Hay, P.S. & Hancock, L.M. 1904: The Hay report.



Lawless, J.V., 2002: New Zealand's geothermal resource revisited. 7th Annual seminar, New Zealand Geothermal Association, Taupo.

Luketina, K., in prep: Reserves of geothermal energy in the Waikato. Unpublished internal Environment Waikato report.

Lund, J., Sanner, B., Rybach, L., Curtis, R., and Hellstrom, G. 2003: Geothermal (ground-source) heat pumps: a world overview. Geo-Heat Centre Quarterly Bulletin 25 No 3: 1-10.

MAF, 2005: Ministry of Agriculture and Forestry website, Production statistics 2005: <http://www.maf.govt.nz/statistics/primaryindustries/forestry/index.htm>

Ministry of Economic Development (MED), 2003: Energy Outlook to 2025.

Ministry of Economic Development (MED), 2006: Energy Data File January 2006

Mongillo, M.A., Clelland, L., 1984: Concise listing of information on the thermal areas and thermal springs of New Zealand. DSIR Geothermal Report No. 9.

NIWA, 2006a: The National Climate Database

NIWA, 2006b: http://www.niwascience.co.nz/pubs/wa/13-4/images/renewable3_large.gif/view

NIWA, 2006c: http://www.niwascience.co.nz/pubs/wa/13-4/images/renewable4_large.gif/view

NIWA, 2006d: http://www.niwascience.co.nz/pubs/wa/13-4/images/ocean2_large.gif/view

OECD, 2006 Factbook 2006: Economic, Environmental and Social Statistics

Parsons Brinkerhoff Associates, 2005: Hydro-electric potential in New Zealand – a hydro-electric resource database. Report prepared for Electricity Commission.

Rybach L. (1997) Market Penetration of BHE Coupled heat pumps. The Swiss Success Story. Geothermal Resources Council Transactions, Vol 22, September 20-23,1998.

Statistics NZ, 2002: Statistics New Zealand website: <http://www.stats.govt.nz>

Thain I., Reyes A.G. and Hunt T. (2006) A practical guide to exploiting low temperature geothermal resources. GNS Science Report 2006/09

Tonkin & Taylor, 1982: Local hydroelectric assessment Waikato Valley Authority area Stage 2. Unpublished report.

Works Consultancy Services, 1990: Hydro resources of New Zealand.

SINCLAIR KNIGHT MERZ



Appendix A Previously Identified Hydro Schemes

Scheme No	Site	Head (m)	Output (MW)	Energy ⁽¹⁾ (GWh)	Remarks
	Waikato/Lake Taupo				
Wk1 ⁽³⁾	Upper Waikato River at Desert Road	71	1.1	4.8	
Wk2 ⁽³⁾	Mangatoetoenui Stm at aggregate plant ⁽²⁾	90	5.7	24.9	Alternatives 2.4 MW
Wk3 ⁽³⁾	Waihohonu Stm at Desert Rd	90	10	43.8	Alternatives 8.5 & 5 MW
Wk4 ⁽³⁾	Waihohonu Stm above Desert Rd	51	4.8	21	
Wk5 ⁽³⁾	Wairehu Canal	36	11.3	49.4	
Wk6 ⁽³⁾	Waihi Stream	125	1.1	4.8	
Wk7	Kuratau River at Moerangi	100	3.7	16.2	Alternative 2.4 MW
Wk8 ⁽³⁾	Waihaha River West Taupo		9.8	42.9	
Wk9 ⁽³⁾	Waitahanui River East Taupo		3.4	14.8	Alternative 1.1 MW, 2.4 MW
Wk10 ⁽³⁾	Tauranga Taupo R. headwaters		5.8	25.4	Alternative 5 MW
Wk11	Waikato River at Huka falls		40	175.2	Alternative 4.7 MW, 20.5 GWh
Wk13 ⁽³⁾	Waipahihi	28	0.3	1.3	
Wk15 ⁽³⁾	Waihohonu	54	6.3	27.5	
Wk16 ⁽³⁾	Waihohonu	57	3.2		
Wk17 ⁽³⁾	Lake Rotopounamu	140	0.5	2.1	
Wk18 ⁽³⁾	Whanganui	95	2.1	9.1	
Wk19 ⁽³⁾	Waihora	50	1.3	5.6	
Wk20 ⁽³⁾	Hinemaiaia	42	1.3	5.6	
Wk21	Tauranga-Taupo	36	3.8	16.6	
Wk22 ⁽³⁾	Waipapa river		4.8	21	Alternatives 1.8,2,3, MW
Wk23 ⁽³⁾	Mangawhio Stm		3.2	14	
Wk24	Pokaiwhenua Stm at Pearsons Rd		1.4	6.1	
Wk25 ⁽³⁾	Mangatutu ⁽²⁾	52	0.7	3	
Wk26	Mangatahae	125	0.9	3.9	
Wk27	Lake Waipa ⁽²⁾	34	1.2	5.2	
Wk55	Waikato at Papariki		20		At the head of Lake Onakuri
Wk56	Waikato at The Narrows		20		Downstream of Karapiro Power Station
Wk58 ⁽³⁾	Waimarino		4.3	18.8	Alternative 2.0 MW, 61 m



Scheme No	Site	Head (m)	Output (MW)	Energy ⁽¹⁾ (GWh)	Remarks
					head
	Waipa River				
Wk28 ⁽³⁾	Waipa River at Okahura Stm		9	39.4	
Wk29 ⁽³⁾	Tunawaea Stm		10	43.8	Alternative is 2.7 MW
Wk30 ⁽³⁾	Waipa River		2.4	10.5	
Wk31	Waipa ⁽²⁾	26	3.2	14	
Wk32	Mangatutu ⁽²⁾	90	2.5	10.9	
Wk33 ⁽³⁾	Waipari	87	1	4.3	Alternative 0.75 MW, 72 m head
Wk34 ⁽³⁾	Waipari	72	0.75	3.2	
Wk35	Mangakomua	70	0.4	1.7	
Wk36 ⁽³⁾	Mangauika	80	0.6	2.6	
Wk37 ⁽³⁾	Kaniwhaniwha	42	0.8	3.5	
	West Coast				
Wk41 ⁽³⁾	Makomako Stm	140	1.1	4.8	
Wk42 ⁽³⁾	Marokopa Falls	119	6.7	29.3	
Wk43 ⁽³⁾	Tawarau River	76	4	17.5	
Wk44 ⁽³⁾	Mokau River near mouth and alternatives upstream	36	29	127	Alternative 20 MW
Wk46	Mokau River below Wairere falls		9.2	40.2	
Wk47	Mokau River at Tauranui falls		1.6	7	
Wk48 ⁽³⁾	Mapiu Stm at Omaru falls		2.1	9.1	
Wk49 ⁽³⁾	Pakoka	95	0.5	2.1	
Wk50	Waiharakeke ⁽²⁾	120	0.6	2.6	
Wk51 ⁽³⁾	Puaroa	32	0.4	1.7	
Wk52 ⁽³⁾	Awakino	36	3.5	15.3	
Wk53	Kihikihi	58	0.75	3.2	
Wk54	Karetu	54	0.85	3.7	
Wk57 ⁽³⁾	Mokau River		40		40 km upstream from the river mouth

Notes:

⁽¹⁾ Energy estimated at 50 % plant factor.

⁽²⁾ Site location not known.

⁽³⁾ Potentially within or close to Department of Conservation land or Native forests areas.



Appendix B Resource Maps