

## Renewable Energy Assessment

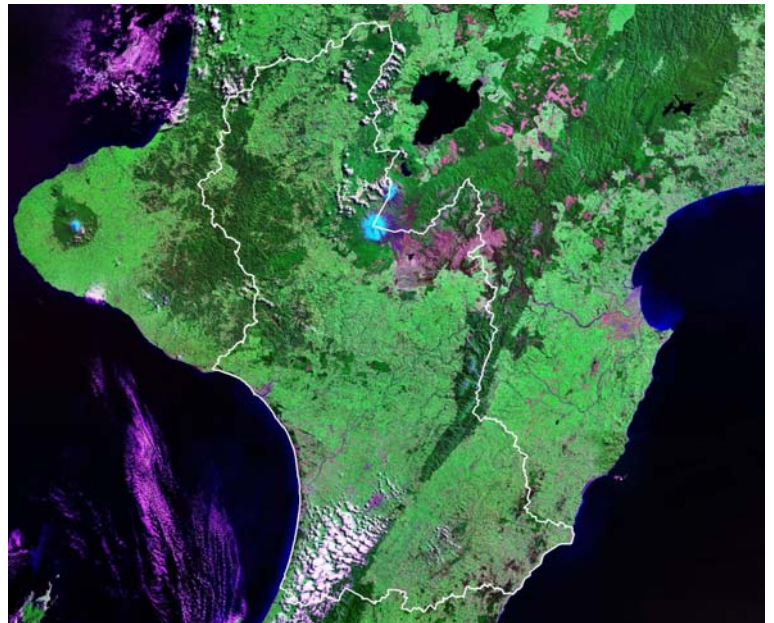

### MANAWATU-WANGANUI REGION

- Final Report
- 20 July 2006



# Renewable Energy Assessment

## MANAWATU-WANGANUI REGION

- Final Report
- 20 July 2006

---

Sinclair Knight Merz  
25 Teed Street  
PO Box 9806  
Newmarket, Auckland New Zealand  
Tel: +64 9 913 8900  
Fax: +64 9 913 8901  
Web: [www.skmconsulting.com](http://www.skmconsulting.com)

**COPYRIGHT:** The concepts and information contained in this document are the property of Sinclair Knight Merz Limited. Use or copying of this document in whole or in part without the written permission of Sinclair Knight Merz constitutes an infringement of copyright.

**LIMITATION:** This report has been prepared on behalf of and for the exclusive use of Sinclair Knight Merz Limited's Client, and is subject to and issued in connection with the provisions of the agreement between Sinclair Knight Merz and its Client. Sinclair Knight Merz accepts no liability or responsibility whatsoever for or in respect of any use of or reliance upon this report by any third party.



## Executive Summary

This study aims to identify and assess the renewable energy potential in the Manawatu-Wanganui Region and assist Horizons Regional Council (HRC) to identify where it can play a role in realising that potential using both regulatory and non-regulatory approaches.

The uptake of renewable energy is constrained by a wide range of barriers that not only includes the technical challenges and costs of developing such resources, but also the cultural and environmental concerns surrounding the use of natural resources.

Most renewable energy projects have relatively high capital costs for plant and a revenue stream that is linked to the often periodic or intermittent nature of some renewable sources. The potential effects on areas of high cultural, ecological and landscape value mean that there are limitations as to where renewable projects may be acceptable. Most projects attract opposition from some sectors and face long consenting and development times.

At the same time, greater uptake of renewable energy presents national benefits such as enhanced security of supply and reduced climate change effects. In addition, greater uptake of renewable energy would allow regions, districts and cities to address issues such as: high liquid fuel and electricity costs that could contribute to a significant economic downturn; transmission / distribution constraints leading to supply disruptions and loss of economic activity; uncertainties associated with other conventional energy sources such as gas reserves and coal fired power plants which may lead to local supply shortfalls; and the economic opportunities presented by the application of mature, cost effective renewable energy technologies in the short-term and the development / commercialisation of emerging technologies in the medium-term.

An initial assessment of the renewable energy development potential of the region is provided in this report. The estimates of renewable energy potential seek to identify major resources that are available and to provide an indication of their relative magnitude. It is to be noted that the assessment has not accounted for how environmental and cultural issues will affect renewable energy potential. Rather, the assessment presents indicative estimates for the amount of renewable energy that could be realised in terms of the resource available outside National Parks and Department of Conservation lands (as a working, first order definition of what projects may be environmentally acceptable) using technologies that are already economic or are likely to become economic over the course of the next ten years (i.e. the review period of Regional Policy Statements).



For the Manawatu - Wanganui Region, this renewable potential comprises:

- Approximately 200-400 MW of additional wind capacity. This excludes the existing 160 MW and the 140 MW under construction, and will depend largely on the degree of acceptance of adverse effects.
- Remaining hydro potential of about 600 MW in mini, small, and medium scale projects outside Department of Conservation lands and Native Forest areas, compared to the existing installed capacity of almost 40 MW.
- Wave energy in the hundred megawatt range, ignoring environmental constraints and conflicts with other maritime users.
- About 27 million litres of ethanol per year for transport fuel from grain crops currently grown in the region. About 60 million litres per year of ethanol or 250 GWh/year of electrical energy from woody biomass derived from low-grade forestry.
- Significant potential for solar thermal hot water systems, considerably less for solar photovoltaic.

**Development of this renewable potential could be assisted by:**

- Increasing the range of expertise within the council such that the council's capacity with regard to renewable energy is commensurate with that of its other functions, *e.g.* soil conservation or water quality.
- Developing an energy plan / strategy.
- Developing spatial representations of renewable energy resources overlaid with information relating to development constraints (*e.g.* outstanding landscapes, areas of high cultural value).
- Establishing a programme of energy forums involving selected councils from across New Zealand.
- Advocating the implementation of appropriate economic instruments at a national level.
- Working with energy generators, District Councils, tangata whenua and other interested bodies to develop industry codes of practice for renewable energy production.

**Regional Policy Statements**

- Identifying in the Regional Policy Statement, areas within the region suitable for renewable energy development including wind, hydro, geothermal and marine based generation.
- Ensuring that the Regional Policy Statement includes a series of objectives and policies outlining how "trade offs" between localised effects and the benefits of renewable energy should be made.



- Amending the Regional Policy Statement to recognise the potential future renewable energy technologies and make high level policy provision for such
- Monitoring the state of technology development and making appropriate provision for emergent technologies by making changes to the Regional Policy Statement.

### **Regional Plans**

- Ensuring that Regional Plans provide for existing renewable energy generation facilities.
- Amending Regional Plan rules to:
  - reduce consent thresholds for energy generation based on renewable resources
  - provide longer consent periods for renewable energy projects
  - provide greater air discharge thresholds for biomass energy generation where this is consistent with ambient air quality criteria
  - recognise the potential of and make high level provision for future renewable energy technologies.
- Monitoring the state of technology development and by making changes to Regional Plans to make appropriate provision for developing technologies.

### **District Plans**

- Ensuring that District Plans provide for existing renewable energy generation facilities.
- Working closely with the District Councils within the region to ensure that district plans reflect the renewable energy objectives and policies of the Regional Policy Statement.
- Amending District Plans to:
  - ensure that rules do not preclude renewable energy development in areas identified in the Regional Policy Statement (*e.g.* landscape protection areas should not include areas deemed suitable for wind power generation in the Regional Policy Statement).
  - give effect to the objectives and policies proposed above for the Regional Policy Statement
  - make appropriate provision for various scale energy generation facilities
  - allow small scale renewable energy production (*e.g.* solar and wind) as permitted activities
  - provide subdivision rules that encourage appropriate site orientation in order to support solar heating and power generation and reduce shading
  - ensure that rules do not unreasonably preclude domestic scale renewable energy production (*e.g.* allows solar panels on roofs) and protect solar access to nearby properties.



## Contents

<b>1.</b>	<b>Introduction</b>	<b>1</b>
1.1	Background	1
1.2	Study Objectives	1
1.3	Report Structure	2
1.4	Data Sources and Quality	3
<b>2.</b>	<b>Drivers</b>	<b>4</b>
2.1	Introduction	4
2.2	Economic Growth	4
2.3	Current Energy Mix	5
2.4	Energy Costs	8
2.5	Security of Supply	10
2.6	Local Benefits	12
2.7	Climate Change	13
2.8	Resource Management Act	13
2.9	Barriers to Renewable Energy	15
2.10	Potential Role for Local Government	18
<b>3.</b>	<b>Technologies</b>	<b>19</b>
3.1	Technical and Economic Considerations	19
3.1.1	Wind power generation	19
3.1.2	Solar PV generation	20
3.1.3	Solar thermal conversion	20
3.1.4	Hydro generation	20
3.1.5	Geothermal power generation	21
3.1.6	Marine power generation	21
<b>4.</b>	<b>Renewable Energy Potential</b>	<b>31</b>
4.1	Introduction	31
4.2	Wind	31
4.2.1	Wind Resource	31
4.2.2	Potential Electricity Generation from Wind	32
4.3	Solar	36
4.3.1	Solar Resource in the Manawatu-Wanganui Region	36
4.3.2	Potential for Solar Thermal	38
4.3.3	Potential for Solar Photovoltaic	38
4.3.4	Potential for Passive Solar Building Design	39
4.4	Hydro	39



4.4.1	Previous Hydropower Capacity Studies	39
4.4.2	Background	41
4.4.3	Developed Hydropower Resources	42
4.4.4	The Market for Hydropower Development	42
4.4.5	Possible Future Hydropower Potential	42
4.4.6	Other Possible Hydropower Options	44
4.4.7	Summary	45
<b>4.5</b>	<b>Biomass</b>	<b>45</b>
4.5.1	Biomass Resource in Manawatu-Wanganui Region	45
4.5.1.1	Agricultural Crops for Energy	46
4.5.1.2	Forestry and Wood Processing Residues	48
4.5.1.3	Short Rotation Woody Biomass for Energy	48
4.5.1.4	Livestock Farming – Dairy and Meat	49
4.5.1.5	Sewage	51
4.5.2	Technology	51
4.5.2.1	Transport Biofuels	51
4.5.2.2	Electricity generation	54
4.5.3	Summary of Resource Potential	54
<b>4.6</b>	<b>Geothermal</b>	<b>54</b>
4.6.1	Power Generation	54
4.6.2	Direct Use	55
4.6.3	Summary of Resource Potential	59
<b>4.7</b>	<b>Marine</b>	<b>59</b>
4.7.1	Tidal Resource	59
4.7.2	Wave Resource	62
<b>5.</b>	<b>Enabling Assistance</b>	<b>66</b>
5.1	Introduction	66
5.2	Renewable Energy Expertise	66
5.3	Renewable Energy Plans / Strategies	66
5.4	Resource / Constraint Mapping	67
5.5	National Renewable Energy Forums	67
5.6	Economic Instruments	67
<b>6.</b>	<b>Regulatory Approaches</b>	<b>69</b>
6.1	Current Regulatory Approaches	69
6.2	Potential Regulatory Approaches	71
6.2.1	Identification of Suitable Renewable Energy Locations	71
6.2.2	Non-Locational Policy Development	73
6.2.3	Consents	74
6.2.4	Domestic or Small Scale Developments	75
6.2.5	District Plans	76



6.2.6	Future Proofing Policy Statements and Plans	76
<b>7.</b>	<b>References</b>	<b>77</b>
<b>Appendix A</b>	<b>Previously Identified Hydro Schemes</b>	<b>79</b>
<b>Appendix B</b>	<b>Resource Maps</b>	<b>82</b>



## Document history and status

Revision	Date issued	Reviewed by	Approved by	Date approved	Revision type
Draft Final	19 June 2006	Phil White	Greg Ussher	19 June 2006	
Final	20 July	James Muir	James Muir	20 July 2006	Minor corrections and clarifications

## Distribution of copies

Revision	Copy no	Quantity	Issued to
Draft Final	pdf	1	Selwyn Blackmore, EECA
Draft Final	pdf	1	Fiona Gordon, Horizons Regional Council
Final	pdf	1	Sharleen Hannon, Selwyn Blackmore, EECA
Final	pdf	1	Fiona Gordon, Horizons Regional Council

<b>Printed:</b>	21 July 2006
<b>Last saved:</b>	21 July 2006 04:18 PM
<b>File name:</b>	I:\APWR\Projects\AP01157\Deliverables\Wanganui\Horizons Final.doc
<b>Author:</b>	Phil White
<b>Project manager:</b>	Phil White
<b>Name of organisation:</b>	Energy Efficiency and Conservation Authority
<b>Name of project:</b>	Regional Renewable Energy Assessment
<b>Name of document:</b>	Manawatu-Wanganui Regional Renewable Energy Assessment
<b>Document version:</b>	Final
<b>Project number:</b>	AP01157



# 1. Introduction

## 1.1 Background

The growth in New Zealand's energy demand over the past three decades has mainly been met by non-renewable sources despite the widespread availability of potential renewable resources throughout the country.

Renewable energy resources face barriers to development that often include high capital costs, difficulty securing access to use natural resources and the practicalities of delivering the energy to where it is to be used. Consequently, the Government has developed energy strategies and made recent changes to the Resource Management Act (RMA) to encourage greater uptake of renewable energy, reduce climate change effects and increase security of energy supply.

While councils and territorial authorities play a significant role in the consenting process for any renewable energy development, this role has (with a few notable exceptions) largely been in reaction to applications. Under the recent changes to the RMA there is a greater requirement on Councils to provide for renewable energy, but as yet there is no coherent knowledge base on the nature of the resources themselves nor a precedent for policy development that meets the new requirements.

## 1.2 Study Objectives

The Energy Efficiency and Conservation Authority (EECA) has implemented a program of Renewable Energy Assessments to assist councils with their policy and plan reviews and their new infrastructure responsibilities for renewable energy under the RMA.

EECA appointed Sinclair Knight Merz (SKM) to undertake a study whose objectives were to identify, assess, report and advise on the:

- Renewable energy potential in each region.
- Councils' role in realising the potential.
- Council's regulatory approaches.
- Information to enhance councils' knowledge.

By providing reliable renewable energy resource information and analysis, these assessments will help direct accurate targeting of renewable energy development opportunities; raise the profile of renewable energy; and provide a sound underpinning of policy development and private investment in renewable energy.



This report is one of eight assessments prepared under this program.

In New Zealand there are a total of 85 councils. In addition to 53 district councils and 15 city councils, territorial authorities which fall under the control of 12 regional councils, there are 5 unitary authorities that lie outside the jurisdiction of a regional council and have responsibilities of both territorial and regional councils. After discussions led by EECA, six regional councils and two unitary authorities (Marlborough and Tasman) were included within the study:

- Environment Canterbury
- Waikato Regional Council
- Horizons Regional Council
- Marlborough District Council
- Horizons Regional Council
- Horizons Regional Council
- Tasman District Council
- Greater Wellington Regional Council

Throughout this report, 'council' is used as a collective term for regional councils and unitary authorities.

### 1.3 Report Structure

The remainder of this report is structured in the following manner:

- **Chapter 2 - Drivers** outlines the national-level drivers for renewable energy in terms of: policy, energy use, supply and pricing. This chapter also provides a summary of key barriers to greater uptake of renewable energy.
- **Chapter 3 - Technologies** presents a tabular summary of existing and emerging renewable energy technology options for New Zealand.
- **Chapter 4 - Local Potential** describes the region's renewable energy resource and provides a preliminary indication of the magnitude of the utilisable resource.
- **Chapter 5 - Enabling Assistance** provides suggestions for how the council could promote renewable energy using non-regulatory methods.
- **Chapter 6 - Regulatory Approaches** summarises the region's existing regulatory approach to renewable energy and outlines alternative approaches for consideration.



Reports have been prepared for each of the eight councils using the above structure. In addition, a summary report has been prepared for EECA.

#### **1.4 Data Sources and Quality**

This assessment of the renewable energy potential within the regions relies primarily on previously published, publicly available information and data. We have used recent summaries of renewable energy potential, but where possible also reverted to the original sources of data.

Some of these sources are contradictory or very non-specific. While some of the available data (such as the hydro power potential) is quite detailed and has been thoroughly reported, other data (such as the wind energy) are poorly defined by existing assessments and not reliable for identifying more than broad parts of the regions that may have high energy potential.

Commentary on the status of marine energy technologies and their costs has been provided by the New and Renewable Energy Centre (NaREC) in the UK which is an independent test facility and technology assessment specialist. NaREC also made first order assessments of tidal current energy from basic published flow data.

The timing and scope of this work has not allowed any extensive new independent assessment of natural resources, although we have re-evaluated some technical and cost criteria for defining resources within the earlier assessments based on our own recent resource evaluations for individual projects or made some preliminary estimates based on published primary information.

Where no energy assessment data has been published (such as tidal current energy) we have made preliminary estimates using suitable guidelines applied to primary data that may be available (such as current velocity in the case of tidal flows). Estimates of the portion of the resource that may practically be used have been made by determining whether any restrictions such as Conservation land may restrict access.

Overall, the resource assessments must be regarded as first order indications of the magnitude and location of each resource. Defining the location, magnitude and probable delivery cost for each type of resource, for each scale of development (from large scale grid-based power generation to micro applications) would be a substantial exercise but could be justified if this were to be the basis for specific designation-based planning approaches.

Existing policy and plan documents for the region have been examined and supplemented by discussions with council representatives.

Interviews have been conducted with TrustPower and Mighty River Power to gain their perspectives on the issues facing the development of renewable energy projects.



## 2. Drivers

### 2.1 Introduction

This chapter outlines the national-level drivers for renewable energy in terms of policy, energy use, supply and pricing. In addition, this chapter provides a summary of key barriers to greater uptake of renewable energy.

### 2.2 Economic Growth

In the majority of countries, there is a very strong link between economic growth and growth in energy supply. Over the years, there has been much discussion of decoupling these two factors in developed countries such that strong economic growth could be achieved whilst reducing total energy supply. Although the energy efficiency of some economies has improved, economic growth has been such that total energy supply has steadily increased.

In New Zealand, the long-term energy efficiency of the economy has improved (Figure 1)<sup>1</sup>. This long term increase in energy efficiency has been brought about by GDP growth that has exceeded growth in total primary energy use (Figure 2). It is to be noted that the total primary energy supply figures are distorted to some degree by the geothermal component which includes a large portion of un-used heat energy.

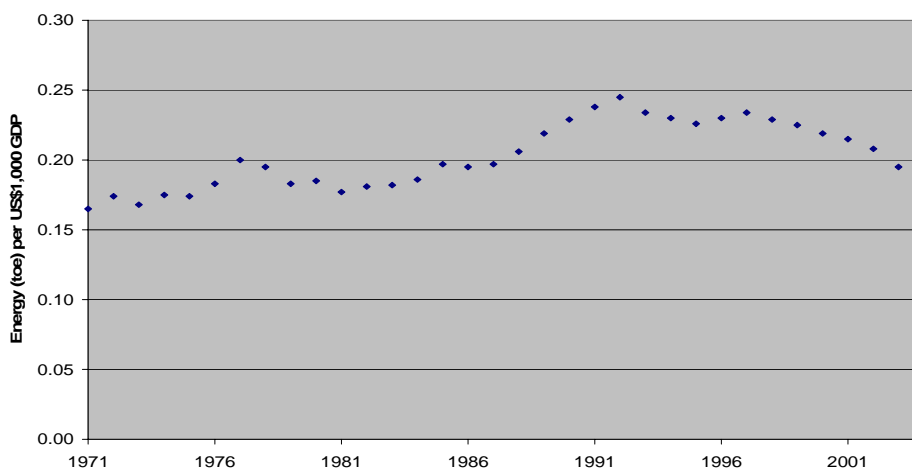

■ **Figure 1 Energy efficiency of the New Zealand economy 1971-2004 (OECD<sup>2</sup>, 2006)**

<sup>1</sup> Tonnes of oil equivalent (toe) per thousand US dollars of GDP using Purchasing Power Parity (PPP).

<sup>2</sup> Organisation of Economic Cooperation and Development

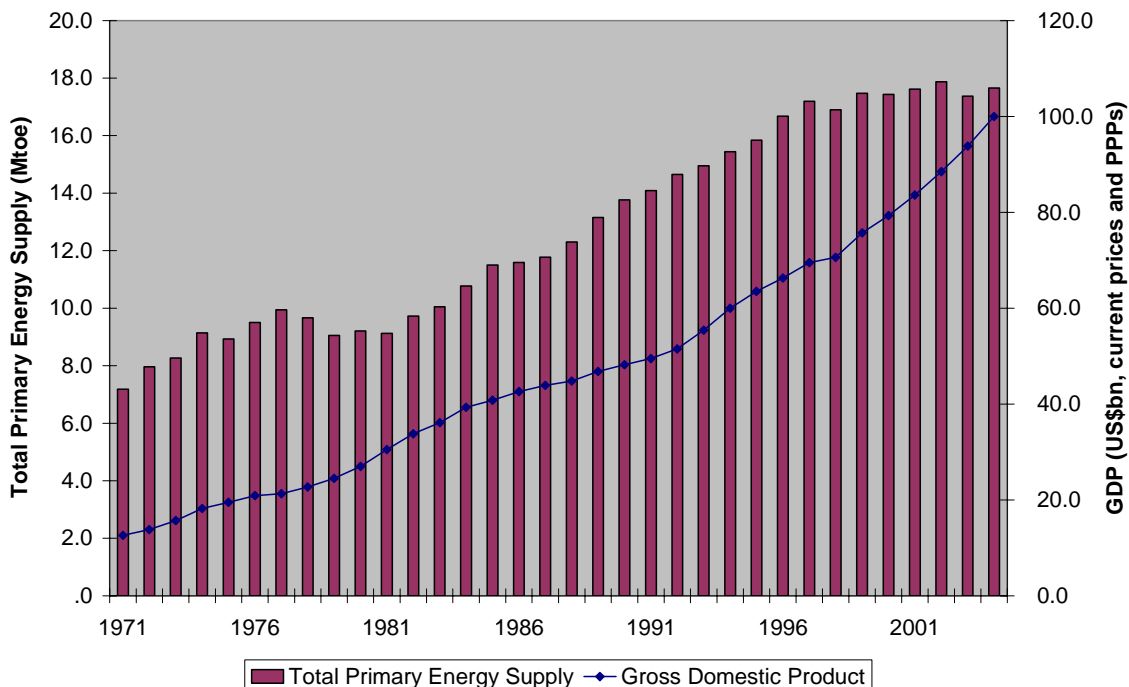

■ **Figure 2 New Zealand economy and energy supply 1971-2004 (OECD, 2006)**

### 2.3 Current Energy Mix

In 2004, about one third of New Zealand’s total primary energy supply was secured from renewable energy sources, one third from imported oil products and the remaining third from indigenous natural gas and a mix of local and imported coal (Figure 3). Of the energy finally used, 40% is for transportation and about 30% is delivered as electricity.

Waste heat used for co-generation of electricity has been reported as a renewable energy in the published energy data, however much of this is derived from coal fired heat (e.g. the Glenbrook Steel Mill) and so is not renewable. As noted above, the renewable energy resource data include all the geothermal heat extracted from the reservoir, making no allowance for the conversion efficiency to electricity. Hence the magnitude of New Zealand’s energy derived from renewable energy sources is effectively over-stated in the published data.

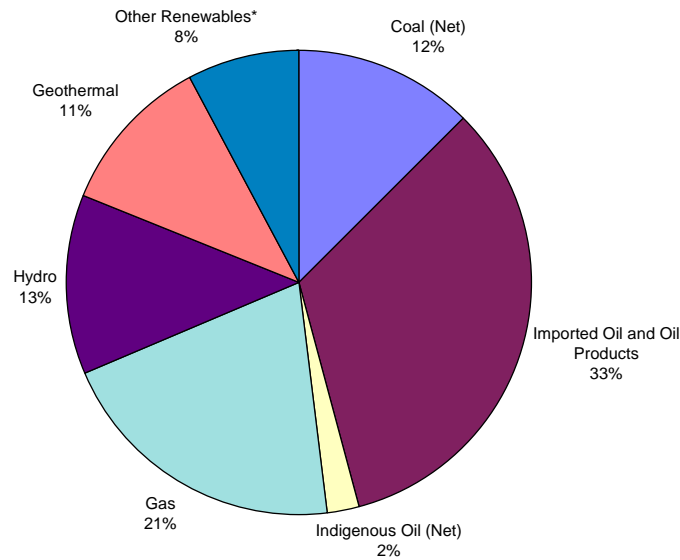

- **Figure 3 New Zealand's primary energy use by source, 2004. NB: Other Renewables\* includes electricity generation from wind, biogas, industrial waste and wood, and solar water heating (MED<sup>3</sup>, 2006).**

Although there has been a growth in total renewable energy use since 1971 (Figure 4), the percentage of energy derived from renewable sources has fallen from 39% to 31% over the same period (Figure 5). The faster growth of non-renewable energy sources is driven largely by the transport sector.

---

<sup>3</sup> Ministry of Economic Development

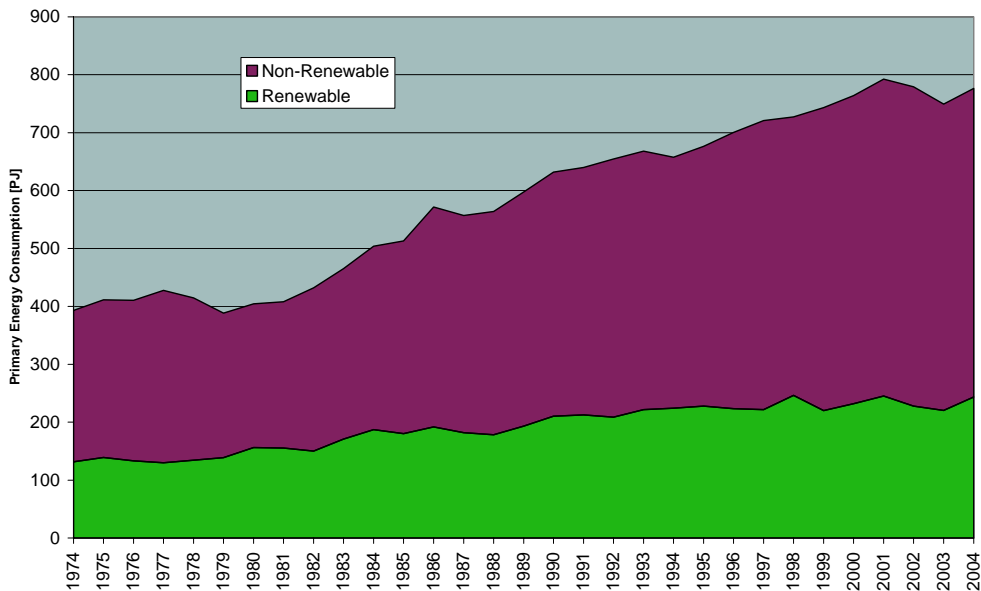

■ Figure 4 New Zealand’s primary energy usage 1974-2004 (MED, 2006)

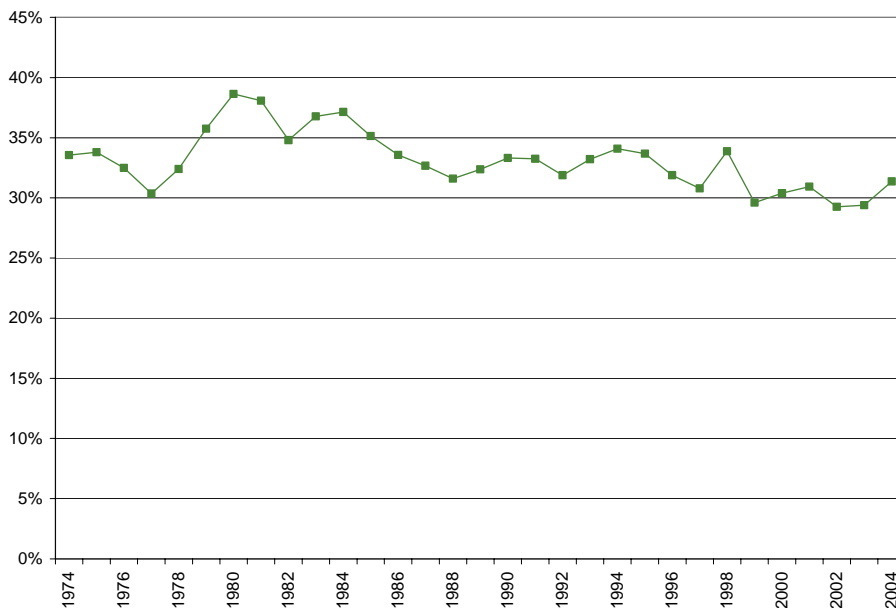

■ Figure 5 New Zealand’s primary energy supply from renewable sources 1974-2004 (MED, 2006)

In summary, the majority of New Zealand’s current energy supply comprises oil, gas and coal, a large proportion of which is imported. Furthermore, the current proportion of energy from renewable sources is near the thirty-year historic low. If the present situation is to be changed, there needs to be a very clear set of benefits for doing so in terms of energy costs, security of supply and climate change.



## 2.4 Energy Costs

The cost of liquid fuels has grown rapidly over recent years, with the price of basic imported petrol (excluding taxes) doubling since 2003 (Figure 6). This trend is very much greater than that predicted by the Ministry of Economic Development (MED) in its 2003 projections of future energy costs, where even under the high cost scenario, crude oil was predicted to be US\$30 / bbl by 2025. However, by 2006, the cost was over US\$70 / bbl. The rapid increase in oil prices is symptomatic of rising energy prices across the board as international demand for raw materials grow, market forces set the price for substitute materials and security of supply concerns continue (e.g. Deffeyes, 2001). Although increases in electricity prices have not been as substantial as those for liquid fuels, certain consumer groups, particularly residential consumers, have seen electricity prices (excluding GST) rise from 12.48c/kWh<sup>4</sup> in 1995 to 16.59c/kWh in 2005, a 30% increase in real terms over ten years (Figure 7).

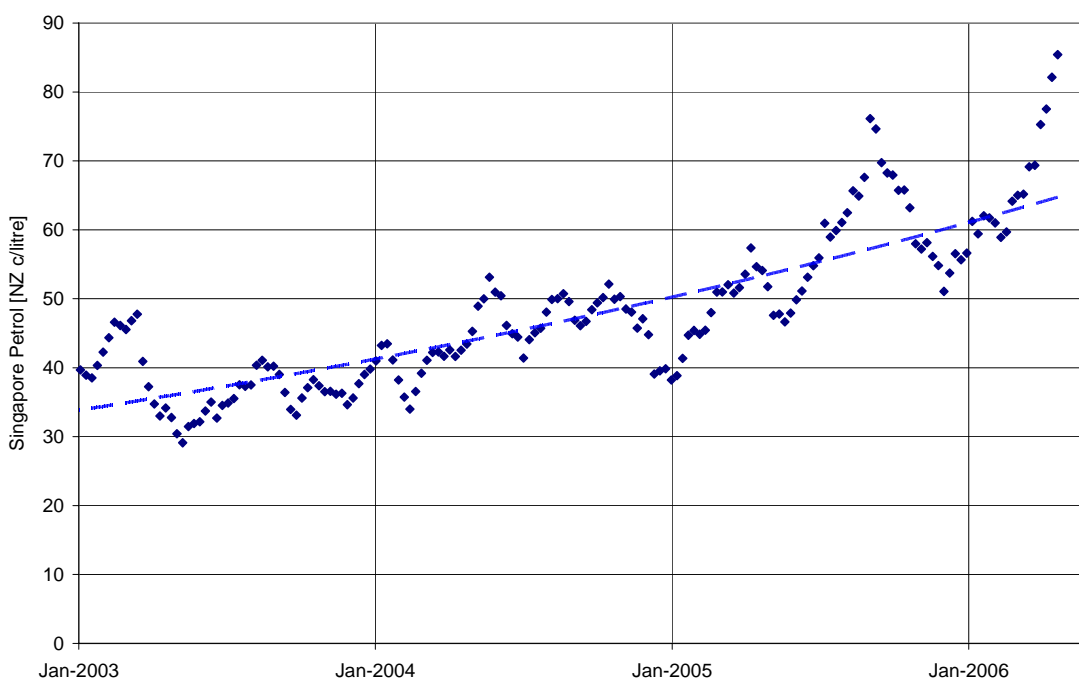

■ **Figure 6 Trends in the cost of imported liquid fuels in New Zealand. Cost of Singapore petroleum (NZ c/litre) (MED, 2006)**

<sup>4</sup> kWh (kilowatt-hour) The standard unit of electricity supplied to the consumer. Equal to 1 kilowatt acting for 1 hour. Or 1 kWh = 3.60 x 10<sup>6</sup> Joules

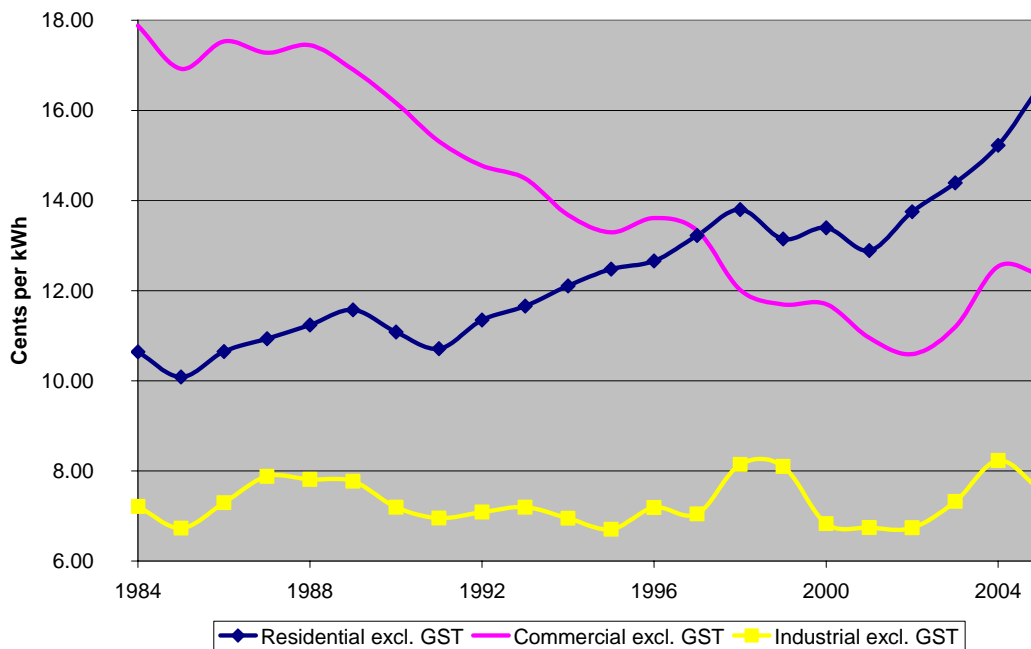

■ **Figure 7 Electricity consumers prices expressed 1984-2005 (Real year end March 2005 prices) (MED, 2006)**

The concern for New Zealand and other developed countries is that rising energy costs may lead to a decrease in energy demand and this, combined with already high labour costs, will reduce economic competitiveness and soften economic growth.

However, one of the key barriers to greater uptake of renewable energy has been cost, particularly upfront capital costs for electricity, which have typically been higher than comparable costs for fossil fuels. However, this situation changes as international prices for oil, coal and gas continue to increase.

Increasing electricity costs will mean that more renewable projects should be economically feasible as the market price of electricity exceeds their cost of generation (see for example Figure 8 from MED’s Energy Outlook to 2025 published in 2003). That MED prediction indicated that renewable energy could in fact dominate the new generation market given suitable market electricity prices.

Similarly, it is expected that biofuels will increasingly become mainstream production if high oil prices are sustained.

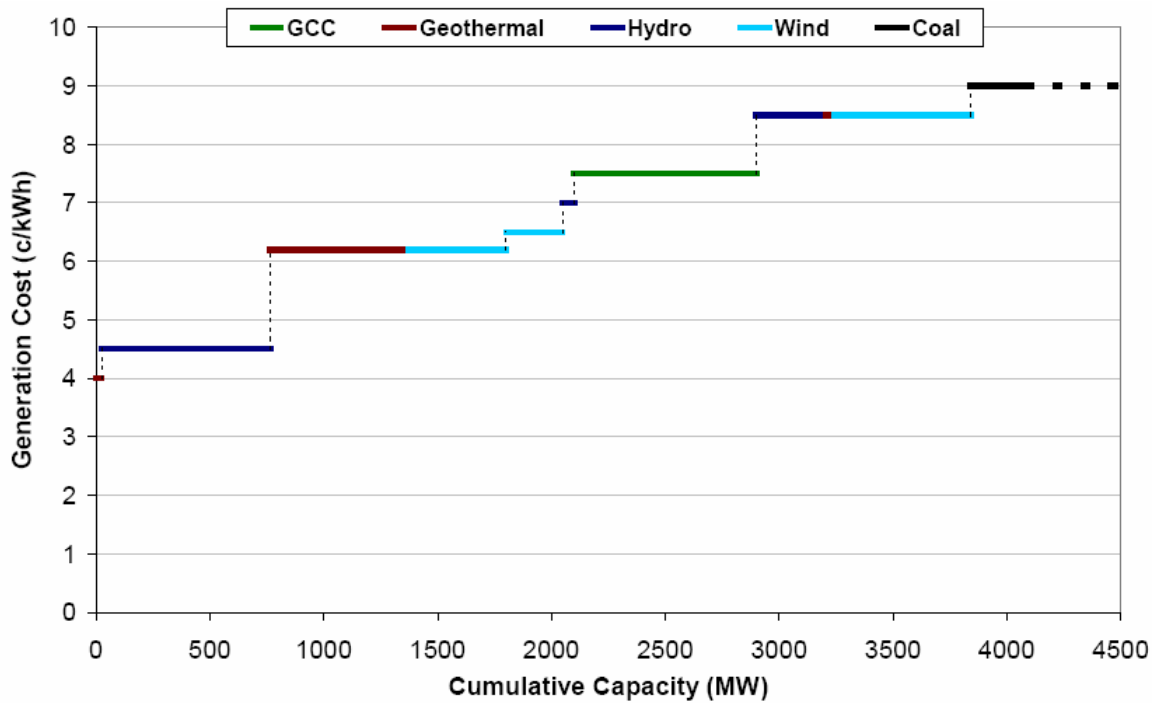

■ **Figure 8 Indicative quantities of new generation sources viable at a range of prices (MED 2003) NB: GCC stands for Gas Combined Cycle**

## 2.5 Security of Supply

A diversified portfolio of renewable energy supply can improve the resilience of the New Zealand economy to future energy supply problems and price shocks. This is recognised as one of the main goals of the National Energy Efficiency and Conservation Strategy (NEECS).

In general, energy sources present some form of risk, including:

- Continuity of supply, either through exposure to international markets or limited indigenous energy reserves
- Limitations for future growth
- Exposure to international price increases

These are detailed in Table 1 for New Zealand’s energy sources.



■ **Table 1 Supply risks to New Zealand’s energy sources**

Energy Source	Risk
Natural gas	<p>Limited life of Maui field, some new discoveries have been made but there are not currently sufficient to replace Maui and confidently enable major expansion of longer term gas usage.</p> <p>Imported Liquefied Natural Gas (LNG) or Compressed Natural Gas (CNG) is a possible supplement or replacement for indigenous gas reserves. It requires additional infrastructure and presents full exposure to international pricing and supply.</p>
Coal	<p>Supplies of low-sulphur, low-ash coal are presently sourced internationally. This has exposure to international pricing and supply.</p> <p>New Zealand has large reserves of lower grade coal that could form a longer term energy supply if and when barriers to its extraction and use are resolved.</p>
Oil and petroleum liquid fuels	<p>There is limited indigenous production of liquid fuels. Over 80% of liquid fuels are imported, presenting exposure to international pricing and supply.</p>
Hydro	<p>New Zealand’s relatively low lake storage volumes mean that available water flows are strongly affected by weather variation. In addition, hydropower’s long term generating capacity could be affected by climate change.</p> <p>New hydropower generation projects have been identified for a number of years and several have recently been progressed. However, these projects have faced major barriers in securing water use consents.</p> <p>Resource consents have no automatic right of renewal and are periodically exposed to public review and objection.</p>
Geothermal	<p>Not exposed to climate change. Resources will change under extraction and require some on-going investment to maintain production. Cost of capital for new developments is linked to international commodity prices (steel, generation plant).</p> <p>Barriers to securing resource consents for new projects.</p> <p>Resource consents have no automatic right of renewal and are periodically exposed to public review and objection. Concern over subsidence has affected one consent renewal.</p>
Wind	<p>Some exposure to climate change.</p> <p>Major barriers to securing resource consents for new projects.</p> <p>Resource consents have no automatic right of renewal and are periodically exposed to public review and objection.</p>

Diversification into a wider range of indigenous renewable energy sources could help mitigate these risks in two ways: reducing dependence on international fuel markets; and reducing dependence on a single form of indigenous renewable resource (*i.e.* hydropower). On the latter issue, since encountering several very “dry” years with consequent low levels of electricity reserve (1992, 2001, 2003) and with little new generation capacity being added to the New Zealand system, the government and major generation companies have recognised the need for additional diversified electricity generation. The generation companies have been making substantial effort to



develop new power generation from hydro, wind, geothermal, gas and coal but this has had limited success. Section 2.9 highlights the key barriers for renewable energy.

## 2.6 Local Benefits

The NEECS recognises the potential benefits for regional economic development that can arise from the development of renewable energy projects. Renewable energy projects (with the exception of biomass plant, where location is an economic consideration) need to be located close to the natural resources upon which they depend and this is usually away from the main urban centres. It is also recognised that for sources such as wind, there is value in having a good geographic spread of projects to increase the likelihood of having a well-balanced system. For the regions, this can mean increased economic activity associated with energy developments and the associated improved strength of local electrical network and supply. Biofuel resources require sustained agricultural activity to grow and harvest fuels, offering a long term and alternative form of economic activity. In addition, some renewable energy sources such as biofuels and geothermal can have secondary benefits in terms of direct heat use for agriculture or industrial processes, and some hydro projects can enable agricultural irrigation schemes.

During the course of the project, a number of councils highlighted pressing energy-related issues in their region, which could be at least partially addressed by a greater uptake of renewable energy.

- Transmission / distribution constraints leading to supply disruptions and associated loss of economic activity or the potential for supply disruption which could limit future growth and inward investment.
- Uncertainties surrounding the future of local energy sources (*e.g.* gas reserves) or local large-scale power generation plants (*e.g.* coal-fired units) which may lead to a supply shortfall, particularly in combination with distribution constraints.
- Liquid fuel and electricity costs which have the potential to cause a serious economic downturn, particularly in those regions where the local economy is largely dependent on agriculture, forestry and other sectors which are large consumers of liquid fuels.
- Regions where there is a substantial renewable resource, which can be used through the application of mature, cost effective technologies with environmental impacts that are broadly acceptable to the community.
- Regions where there is substantial renewable resource, which could be harnessed using emerging technologies over the next years and which have the desire to become regional, national or international technology leaders.
- Regions where there is considerable expertise of new energy technologies, which would benefit from the development of a regional market for their applications.



- A further factor to consider is that in 2013 lines companies will no longer be obligated under Regulation to continue supplies to (uneconomic) rural customers.

## **2.7 Climate Change**

New Zealand has ratified the Kyoto Protocol, which entered into force on February 16, 2005. New Zealand's target is 100%, which means that New Zealand is required under the Protocol to reduce its greenhouse gas emissions back to 1990 levels on average during the First Commitment Period (CP1 or 2008-2012), or otherwise take responsibility for any excess emissions. It was envisaged that for New Zealand this target would be able to be met through a combination of domestic emissions reductions and increases in carbon sinks. It was also anticipated that more significant emission reductions would need to be negotiated for future commitment periods.

In May 2005, an estimate of New Zealand's CP1 emissions position relative to the target was projected to be about 32 million units (tonnes of carbon dioxide equivalent). In December 2005 the net emission deficit was increased to just below 51 million units, reflecting updated information about deforestation intentions. The decision to cancel the carbon tax is expected to increase the deficit to about 64 million units, although no account has been made of any replacement policies currently under consideration.

Renewable energy will significantly assist New Zealand to meet its obligations under the Kyoto Protocol whilst helping to meet New Zealand's growing electricity demand without increasing the use of thermal generation, whose greenhouse gas emissions contribute to climate change.

## **2.8 Resource Management Act**

The Resource Management (Energy and Climate Change) Amendment Act 2004, introduced three new matters into section 7 (Other Matters) of Part II of the Resource Management Act 1991 (RMA), requiring all persons exercising functions and powers under the Act to have particular regard to:

- (ba) the efficiency of the end use of energy
- (i) the effects of climate change
- (j) the benefits to be derived from the use and development of renewable energy; and

To support the section 7(j) amendment, section 2 of the RMA was amended to define "renewable energy" as "energy produced from solar, wind, geothermal, hydro, biomass, tidal, wave, and ocean current sources".



The law relating to these matters has been refined to some extent by the Environment Court in its decision on *Genesis Power Ltd and The Energy Efficiency and Conservation Authority v Franklin District Council A148/2005*. This decision related to a resource consent application to establish a wind farm on the Awhitu Peninsula, south of Auckland.

The Court identified the benefits to be derived from renewable energy to include:

- Security of supply
- Reduction in greenhouse gas emissions
- Reduction in dependence on the national grid
- Reduction in transmission losses
- Reliability
- Development benefits
- Contribution to the renewable energy target.

The Court also gave considerable weight to the positive effects of renewable energy in its consideration of the decision and also found support for the project in its general assessment of Part II of the Act.

The 2004 amendment also removed the regulatory means for controlling greenhouse gases, as at the time when the Amendment Act was being developed, fiscal measures (namely the carbon tax) were being introduced to have the same effect. As a result, councils now cannot make rules which control the discharge of greenhouse gases on the basis that they contribute to climate change, nor can they consider climate issues in relation to resource consents. Rules relating to the control of greenhouse gases for climate change purposes made prior to enactment no longer apply. However, historic resource consent decisions still stand.<sup>5</sup>

In 2005, the Act was further amended by giving additional powers to councils to:

*“the strategic integration of infrastructure with land use through objectives, policies, and methods:”*

The amendment also provided a wide definition of infrastructure which includes:

*“(a) pipelines that distribute or transmit natural or manufactured gas, petroleum, or geothermal energy:*

---

<sup>5</sup> A Private Members Bill is currently before Parliament that will have the effect of reversing these particular provisions.



*“(d) facilities for the generation of electricity, lines used or intended to be used to convey electricity, and support structures for lines used or intended to be used to convey electricity, excluding facilities, lines, and support structures if a person—*

*(i) uses them in connection with the generation of electricity for the person’s use; and*

*(ii) does not use them to generate any electricity for supply to any other person:*

These powers may be implemented by providing objectives, policies and methods in regional policy statements that will provide greater direction as to the locations and co-ordination of such infrastructure.

The 2005 amendment to the Act also changed the status of Regional Policy Statements. Previously District Plans were required to be not inconsistent with a Regional Policy Statement. The 2005 amendment altered this so that District Plans are now required to give effect to a Regional Policy Statement. This gives Regional Policy Statements additional powers to direct what provisions are included within District Plans.

Overall recent amendments to the RMA both require and empower Councils to have a greater role in the encouragement of renewable energy generation.

## **2.9 Barriers to Renewable Energy**

There are a range of barriers that have slowed the uptake of renewable energy. These largely relate to the need for individual projects to secure their own “fuel” supply from natural resources while also still having to construct an energy conversion facility (*i.e.* power plant). The locations where these natural resources are found often have other intrinsic value (such as wind resources found in areas of high landscape value, or hydro opportunities in dramatic catchment areas) or the resource itself has other competing uses (such as recreational use of rivers, geothermal features as tourist attractions).

Some of the major barriers to renewable energy are identified in Table 2, along with a brief indication of where councils may have some influence on those barriers:



■ **Table 2 Major barriers to renewable energy projects**

<b>Barrier</b>	<b>Description</b>	<b>Council Influence</b>
High capital cost	Projects include the cost of “fuel” gathering as well as energy conversion and hence tend to have high capital cost.  Some technologies are new and do not yet have the economies of scale in plant construction compared to conventional energy sources.	No influence
Intensive “fuel” investigation	Intensive investigation is required for determining resource potential. This is very high for geothermal but less for wind and hydro.	Consents for wind measurement towers, geothermal drilling and river weirs
Low energy density	Many renewable projects have a low energy density – requiring large areas for the collection of fuel and for energy conversion plant. However, some types such as wind and geothermal do not preclude continuation of other uses such as farming.	Land use that is allowed within human and natural land zonings.
Long development time	Most have several stages of development, from resource evaluation, consenting and construction. There are associated development risks at each stage.	Consenting process
Wide consultation Community attitude to natural resource uses	The use of natural resources and construction of plant in natural areas demands a high level of consultation often in the face of significant public opposition.	Planning environment Consenting process
Resources associated with natural features or areas of intrinsic or cultural value	Renewable energy can be associated with natural features that have high intrinsic value, such as wind in outstanding landscapes and hydro in natural waterways. These areas may also have special cultural value to Maori.	Landscape planning, natural area identification.  Balancing effects of development against amenity values in consent process.
Competing uses for the same resource	Recreation use of rivers and irrigation competes with hydro power. Geothermal surface features have a range of uses.	Balancing effects and benefits from competing uses Resource consents to take water
High “mitigation” fees	Due the fact that objectors can impede the consenting process, many affected or interested parties now expect substantial fees in return for their agreement to a development. Consent requirements have resulted in a secondary mitigation fee market that is a barrier particularly for smaller projects.	Planning environment Consenting process
Non-firm nature	Some renewable resources such as solar, wind and marine are periodic or	No influence



Barrier	Description	Council Influence
Transmission requirements	<p>intermittent in nature. This limits their ability to meet peak demand requirements and hence tend not to secure highest market prices.</p> <p>Most renewable energy projects need to be located close to the energy resource and so are dependent on transmission networks to carry the energy to where it is required.</p> <p>Weak transmission networks limit positioning of projects.</p> <p>Developers may be required to build new transmission lines to service their projects.</p>	Consents and designations for transmission upgrades or new lines
Environmental considerations	<p>Councils may find it difficult integrating increased interest in renewable energy alternatives with local environmental concerns, already identified in existing or operative legislation.</p> <p>For example the use of biomass as an alternative to electricity could be viewed as an air quality problem, rather than an energy supply solution.</p>	<p>Planning environment</p> <p>Consenting process</p> <p>Non-regulatory</p>

Fossil-fuelled projects face few of these obstacles. For example two gas-fired power plants currently (2006) under construction did not require notified consents. The 1,000 MW<sup>6</sup> Huntly plant has been reverted to being fuelled by coal so that the gas it would have otherwise used can be redirected to a new efficient CCGT gas-fired plant under construction. However, the conversion of the Marsden B plant to coal is subject to appeal on conditions by the developer and on environmental grounds by environmental groups opposed to the project.

Recent successful renewable energy projects have included an expansion to the Tararua wind farm and an expansion to the Mokai geothermal plant. These projects were located at existing power development sites and as such were readily able to obtain resource consents.

However, “green-field” projects tend to face greater difficulty within the RMA processes. The proposed expansions of the geothermal projects at Ngawha and Kawerau have been declined or face appeals because of perceived effects. Developments planned at new locations have had to

---

<sup>6</sup> The unit for measuring power is the Megawatt (MW). Power is the rate at which energy is generated / consumed, i.e. 1MW means that one million joules of energy is generated / consumed every second. As crude approximations: a full petrol tank in an average size car contains one million joules of energy; a single wind turbine has a 1MW capacity



follow a more difficult path. The hydro project “Aqua” was reportedly abandoned due to a perception of major public opposition, and several wind farms have faced similar opposition.

Developers report that small renewable projects are no longer viable to consider for development as the costs and delays associated with the consenting processes and the “mitigation” fees can be as great as for large projects. However, if fossil fuel costs and wholesale electricity prices continue to increase in line with recent trends then the higher market return possible for alternative energy sources will tend to enable the development of more renewable energy projects.

## **2.10 Potential Role for Local Government**

While development of renewable energy resources can have benefits that are of national and regional value, these benefits apply to a variety of sectors and are often not manifested in a way that is tangible and of direct value to the individual developer. In the absence of direct financial or other enabling incentives, the wider national and regional benefits therefore may not surmount the barriers to most forms of renewable energy development.

This is the reason that central government has engaged in strategies to promote renewable energy. Some of the barriers to renewable energy development are manifested in the regions and districts, and the councils have a key role in the process for approving or declining these projects and more fundamentally, for establishing policies and plans that proactively support greater uptake of renewable energy. The Councils and their policy and planning instruments can therefore have a significant effect on the future uptake of renewable energy in New Zealand.



### 3. Technologies

This section provides a summary of technologies which are used to use renewable energies. Renewable energies are defined by the RMA as:

- Solar
- Wind
- Hydro
- Geothermal
- Biomass
- Tidal
- Wave
- Ocean Current

Of these, hydro and geothermal are relatively mature technologies, solar, wind and biomass are new and to some extent still developing, while tidal, wave and ocean current are still at the development stage.

#### 3.1 Technical and Economic Considerations

The following paragraphs comment on some issues that affect cost estimates for renewable energy projects and future price trends. All the listed values in Table 3 for capacity factor and cost are indicative only. Renewable energy projects have generally very project specific cost components and need to be assessed on a case by case basis.

##### 3.1.1 Wind power generation

Figure 9 shows the dependency of the generation costs from large scale wind farms on the average wind speed. Note that this graph is only an indication of likely costs for typical projects. Costs can vary significantly between projects, depending on complexity of the terrain and resulting higher costs for access roads or long distance to the grid with high investment needed for the grid connection. The graph shows that currently the electricity prices require average wind speeds of around 8 m/s for projects to be economically viable. A future increase in electricity prices will make areas with lower wind speeds attractive for developers also.

Wind turbine prices have dropped considerably over the last decade due to a large increase in manufacturing rates/capacities and technology enhancement. However, this trend is not expected to continue. Last year saw a general increase in turbine prices, which was partly due to higher steel prices. Furthermore, some manufacturers were forced to increase prices to avoid financial losses and make the business more profitable. Profit margins have been very small in the past due to a very competitive market.

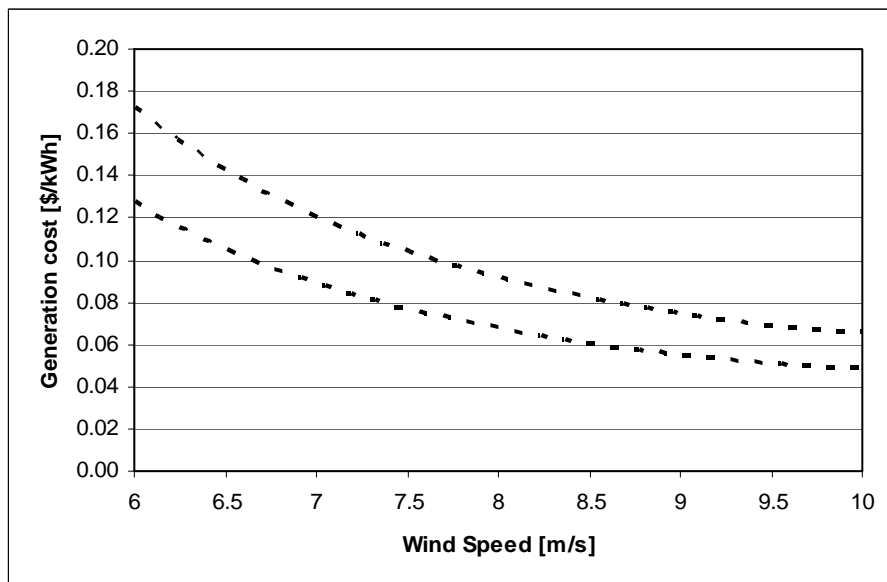

■ **Figure 9 Indication of wind energy generation costs**

### 3.1.2 Solar PV generation

Solar PV system costs have been dropping significantly over the last decade. Furthermore, the efficiency of solar cells is constantly improving. This trend is expected to continue with further production capacity lowering the costs, and further technology developments increasing the efficiency.

### 3.1.3 Solar thermal conversion

Technology used in solar thermal conversion systems continues to advance, reducing production cost and increasing system performance. Ongoing improvements to solar conversion surfaces and effective reductions in convection losses ensures solar thermal conversion efficiency continues to improve. It is believed that this technology will remain as the most economic solar conversion system available for installation in both new and existing houses.

### 3.1.4 Hydro generation

The wide range of cost of generation comes about because of the very site specific nature of projects. The necessary project components and their scale (for example diversion and water conveyance works, environmental mitigation works and choice of equipment) depend very much on the location and the intensity of the potential. Additionally site specific aspects such as topography and geology drive construction costs while local hydrology determines the energy available from the site. Whereas low head schemes have proportionally large (and slow speed)



generating units and relatively low civil works investments, the opposite is the case for high head opportunities where the (small, high speed) machine cost tends to be low, but with a relatively high investment in the diversion works and pipeline. The scheme's proximity to electrical grid, access to site and necessary transportation work (new roads vs. existing) can also affect the project cost substantially, as can the cost of capital (own or borrowed from the market) in the prevailing market conditions.

### **3.1.5 Geothermal power generation**

Geothermal development costs have been relatively stable for some time, although drilling costs in particular have risen over the past year. Many of the recent geothermal power developments in New Zealand (*e.g.* Mokai, Rotokawa and Ngawha) have used wells that were drilled by the government many years ago, thus removing a significant cost and risk component. Similarly, expansion of those projects can draw on a production history that allows greater certainty as to the size of the resource and its capacity to sustain the expanded operation. For example, addition of a binary power plant at Wairakei did not require any additional wells to be drilled, and cost much less than the estimated costs in Table 3, which are for a stand-alone binary plant. Costs are significantly higher for green-fields developments where there are no existing geothermal wells, compared with expansion of an existing development.

The energy in ground at ambient (non-geothermal) temperatures (10-15°C in New Zealand) represents a significant energy resource which can be used with ground source heat pumps (GSHP). This technology is used on a large scale in North America and Europe where the climate, high electricity prices and subsidies make this technology economic. These drivers are largely absent in New Zealand and as a result there has been little use of GSHP's in New Zealand. Use of geothermal heat using ground source heat pumps can save up to 60% on electricity heating costs in a typical New Zealand home but, because of the high installation cost (approximately NZ\$12,000), may only be economic in larger commercial buildings.

### **3.1.6 Marine power generation**

Marine power generation costs are expected to drop considerably over the next decade. It is expected that the cost curve will be similar to the wind power generation. However, it must be noted some cost components, especially Operation & Maintenance, can only be estimated with high uncertainty at this stage.

■ **Table 3 Renewable energy technologies**

<b>Resource / Technology</b>	<b>Technology Description</b>	<b>Technology Status</b>	<b>Type of Application</b> - size - heat / electricity - peak / base / capacity	<b>Environmental Effects</b>	<b>Costs*</b>
<b>Wind</b>					
Wind turbine	Extraction of kinetic energy from the wind flow Horizontal axis wind turbine 2 or 3 blades Direct drive or gearbox AC generation	Well established Commercially available	Large scale Typical modern turbine size 2-3 MW Wind farms up to 300+ MW Intermittent generation Capacity factor: 35-45% Difficult to forecast	Visual impact Noise Shadow flickering Electromagnetic interference	1,700-2,100 \$/kW (installed) approx. 8 c/kWh see comments above
Micro wind	Extraction of kinetic energy from the wind flow Horizontal or vertical axis turbines 2 or 3 blades Direct drive DC generation	Well established Commercially available	Small-scale (<10 kW) Electricity generation or direct drive of water pumps Intermittent generation Difficult to forecast	Minimal visual and noise impact	7,000-10,000 \$/kW 30-40 c/kWh
<b>Solar</b>					
Solar Thermal System	Solar radiation transformed into heat System consisting of solar collector and storage Active systems use a pump whereas passive systems rely on gravitational forces	Well established Commercially available	Small-scale, heat	Minimal visual impact	3,000-6,000 \$ per domestic system 11-17 c/kWh <sub>th</sub>
Solar Photovoltaic	Solar radiation transformed into electricity Solar cells consisting of semiconductor material (either thick or thin technology) Silicon most common semiconductor material	Well established Commercially available	Small-scale, electricity Intermittent generation	Minimal visual impact	grid connected (incl. inverter): 13,000-20,000 \$/kW approx. 80 c/kWh

SINCLAIR KNIGHT MERZ

Resource / Technology	Technology Description	Technology Status	Type of Application - size - heat / electricity - peak / base / capacity	Environmental Effects	Costs*
<b>Hydro</b>					
General	Water passing through a turbine rotates the runner which is harnessed to a generator to produce electricity.				
Run of River	Divert part of river flows to power plant, may consist of small barrage or a weir to store little water at the water diversion area. Often requiring tunnelling to move water to location where head drop can be achieved.	Well established Commercially available	Small to medium scale electricity Capacity Factor: 70-80%	Water extraction, aesthetic effects, ecological effects, recreational activities	3,000-4,500 \$/kW 4-7 c/kWh
Storage	Dam creates water storage upstream of the diversion to be used to generate power on demand	Well established Commercially available	Medium to large scale electricity, peak load Capacity factor 50-70%	Land inundation, effect on aquatic ecosystems (change in habitat, fish migration), water quality, soil erosion, recreational activities, noise	3,500-5,000 \$/kW 7-10 c/kWh
Pumped Storage	In addition to storage at the diversion area, water also stored at the downstream end where spent water is released and pumped back up to reuse it to generate.	Well established Commercially available	Medium to large scale electricity, peak load	Land inundation, effect on aquatic ecosystems (change in habitat, fish migration), water quality, soil erosion, recreational activities, noise	2,500-4,000 \$/kW generation costs: N/A (net consumer)
<b>Biomass</b>					
Direct heat	Biomass (such as woodwaste etc) is burnt to generate heat, either directly or as steam or hot thermal oil.	Well established Commercially available	Available from the smallest domestic scale (wood stoves etc) to NZ's largest industries (pulp & paper).	Air quality may be affected by the smaller-scale developments. Large installations will have sophisticated emissions control systems. Fuel transport will have adverse effects.	Woody biomass: 4 \$/GJ
Electrical generation	Biomass is burnt to generate steam for a power plant.	Well established Commercially available	Economics favours the larger-scale developments,	Power plant developments will have sophisticated	20 MW class woody biomass plant:

Resource / Technology	Technology Description	Technology Status	Type of Application - size - heat / electricity - peak / base / capacity	Environmental Effects	Costs*
			typically greater than 25 MWe, but limited by harvesting and transport costs. Capacity factor: 90%	emissions control systems. Fuel transport will have adverse effects.	3,400 \$/kW 13 c/kWh
Liquid fuels	Very wide range of options for the production of liquid fuels, including hydrolysis and fermentation to ethanol, oil and tallow esterification to biodiesel, gasification and synthesis to methanol and hydrocarbons, pyrolysis etc).	Some technologies are well-established and commercially available (ethanol, biodiesel, etc), others are at prototype and/or early commercial stages (gasification and synthesis, pyrolysis, hydrolysis etc).	Economics favours the larger-scale developments, largely due to technical sophistication, but limited by distributed nature of the resource and the harvesting and transport costs.	Process plant developments will have sophisticated emissions and effluent control systems. Raw materials transport will have adverse effects.	Tallow and oils to biodiesel Plant capacity 120,000 t/year. Plant capital cost \$50 million. Feedstock cost \$460/t, product cost \$0.45/L. Biomass to Methanol Plant capacity 250,000 L/day. Plant capital cost \$250 M. Product cost \$1.1/L, \$61/GJ Biomass to Ethanol Plant capacity 100,000 L/day. Plant capital cost \$128 M. Product cost \$1.75/L, \$75/GJ
Gaseous fuels	Biological degradation (anaerobic digestion, fermentation etc) to generate methane gas.	Well established Commercially available	Available from the smallest domestic and/or farm scale bio-digester to municipal effluent treatment for NZ's largest cities.	Process plant may need sophisticated effluent control systems. Raw materials transport may have adverse effects.	
<b>Geothermal</b>					
Conventional geothermal power plant (steam turbine) possibly with binary plant for steam condensing.	Fluid self-discharges from wells. Steam and liquid water flows are separated. Steam is passed directly through a turbine to generate electricity. Binary plant possibly used for condensing steam and heat recovery from hot	Well established Commercially available, applicable to high temperature (typically >200°C) geothermal fields	Medium to large scale electricity (base load), plus downstream direct heat potential. Capacity factor 90-95%	Air quality (especially H <sub>2</sub> S odour), impact on surface thermal features, shallow aquifers and ecosystems, noise, visual, subsidence, resource depletion	2,500-3,000 \$/kW 5 - 8 c/kWh

Resource / Technology	Technology Description	Technology Status	Type of Application - size - heat / electricity - peak / base / capacity	Environmental Effects	Costs*
	water. Waste fluids mostly reinjected into the ground.				
Binary power plant on medium to low temperature resources	Wells may self-discharge or require pumping. Geothermal fluid heats a secondary (binary) fluid in a closed cycle that is vaporised, drives a turbine, is cooled and condensed.	Well established  Commercially available, most applicable to low temperature (120 to 200°C) geothermal fields. Applied in many USA fields usually with pumped wells. In NZ, binary plant presently only used for heat recovery from water on geothermal projects.	Small to large scale electricity (base load), plus downstream direct heat potential  Capacity factor 90-95%	Air quality (especially H <sub>2</sub> S odour), impact on surface thermal features, shallow aquifers and ecosystems, noise, visual, subsidence, resource depletion	5,000-7,000 \$/kW  7-10 c/kWh
"Enhanced" Geothermal systems (including Hot Dry Rock – HDR)	Geothermal reservoirs that have heat but insufficient water or permeability for conventional extraction. Multiple wells required for stimulating fractures and circulation of a fluid through injection-production well couples. Energy converted to electricity  Potential on margins of existing NZ fields.	At developmental stage in USA, Europe and Australia.  Large heat reserves in some geological environments, hence there is technology development effort.	Projects are likely to be large to enable economy of scale	Effects expected to be minimal compared to conventional geothermal.  Some thermal contraction effects (v minor subsidence)	High cost
Direct use of heat: many potential uses, including:	Paper manufacture Timber drying Other industrial processes Space heating Space cooling Horticulture Aquaculture Bathing, spas	Well established  Commercially available technology exists for most applications.	Range from very small scale (domestic heat pumps) to large scale industrial plants  Capacity factor 90-95%	Depending on the scale of the operation, effects range from negligible to similar to a geothermal power plant	300-400 \$/kW <sub>th</sub>  1-2 \$/GJ
Ground source heat pumps	Heat pump using the ground or groundwater as a heat source or	Well established  Normally some measure of	Range from domestic to commercial building scale.	Minimal effects.  If using groundwater, then	NZ\$12,000 estimated installation cost is higher

Resource / Technology	Technology Description	Technology Status	Type of Application - size - heat / electricity - peak / base / capacity	Environmental Effects	Costs*
	sink. Can achieve very high efficiencies compared to conventional heat pumps using atmospheric heat sinks. Typically used to heat or cool buildings.	custom design in NZ, as there are few suppliers. Wider application in USA, Europe, Japan and China.		affects water temperature.	than standard heating-cooling systems. Electrical input ~25-30% of output.  Viable for commercial buildings if long term efficiency is considered.
<b>Tidal (Kinetic Energy) Ocean Current</b>	Exploitation of velocity component of tide. Flow of water passing turbine blades cause aerodynamic lift. Blades are connected via shaft to electrical generator				
Technology a1	Similar operating principle to vertical axis wind turbine. 2 or 3 blades mounted on a monopole seabed foundation	Large scale 300KW prototype demonstration 3 year sea deployment nearing completion.  1000KW grid connected demonstration prototype planned 2006-2007	In the order of 1MW per installation  Electricity production  Base load contributor – Energy BUT source intermittent but highly forecastable (years in advance)  Capacity factor 40-50%	Yet to be fully understood but generic issues with:  Sub sea noise especially in piling operations  Marine mammal collision  Risk to marine navigation and associated pollution risks  Underwater cabling  -Seabed and habitat disturbance  -Electromagnetic interactions with elasmobranchs	Based upon estimates rather than track record:  Early full scale prototypes 14,000 to 23,000 \$/kW  Cost of energy range of 28-43 c/KWh  Early production models 5,000 \$/kW  Cost of energy approx. 22 c/KWh
Technology a2	As above but floating Vertical axis rotary device on mooring. Either fully submerged or surface piercing.	Number of 500KW grid connected demonstration prototypes planned 2006-2007	In the order of 1MW per installation  Electricity production  Base load contributor – Energy BUT source intermittent but highly forecastable (years in advance)	As above minus piling issue	as above

Resource / Technology	Technology Description	Technology Status	Type of Application - size - heat / electricity - peak / base / capacity	Environmental Effects	Costs*
			Capacity factor 40-50%		
Technology a3	Ducted turbine mounted on seabed via concrete foundation	1MW grid connected prototype demonstration planned 2006-2007	In the order of 1MW per installation Electricity production Base load contributor – Energy BUT source intermittent but highly forecastable (years in advance) Capacity factor 40-50%	As above minus piling issue	as above
Technology a4	Reciprocating aerodynamic foils convert mechanical motion into hydraulic rams power take off device.	100KW grid connected demonstration planned 2007	In the order of 1MW per installation Electricity production Base load contributor – Energy BUT source intermittent but highly forecastable (years in advance) Capacity factor 40-50%	As above minus piling issue	as above
<b>Tidal (Head)</b>	Exploitation of head differential between high and low tide.				
Technology b1	Impoundment (dam) of estuary. Gates within the dam allow water to pass upstream of structure. Closure of gates at high tide creates head height differential across dam as tide falls on downstream side. Operation reversed at low tide. Low hydro	Well established Commercially available technology exists for most applications.	In the order of 100MW per installation Electricity production Base load contributor – Energy BUT source intermittent but highly forecastable (years in	Profound and irreversible change in estuary eco-system	Existing plants are broadly comparable with the upper end of fossil fuel based generation costs Costs are expected to be much higher in NZ due to the lower tidal range.

Resource / Technology	Technology Description	Technology Status	Type of Application - size - heat / electricity - peak / base / capacity	Environmental Effects	Costs*
	turbines may then be used to release head and generate electricity.		advance)		Minimum tidal range currently considered economic for this technology is considered 5m.
Technology b2	Narrow headlands create 'nature' impoundment as head height can vary across the sides of the land mass. The introduction of piping containing water turbines exploits head driven flow.	Yet to be demonstrated at meaningful scale	In the order of 100MW per installation  Electricity production Base load contributor – Energy BUT source intermittent but highly forecastable (years in advance)	Hazard to fish life passing through pipe.  Estimated to be little eco-system impact	unknown
<b>Wave</b>					
Technology a	Oscillating water column: Conversion of wave energy into pneumatic energy, channelled through bi-directional air turbine connected to rotary electrical generator.  Can be configured as floating structure, seabed fixed or fashioned into cliffs or breakwaters	Demonstrated at 500KW grid connected site. Presently with 4 year of operational service	Intermittent energy source. Forecast ability better than wind, but good reliability only based on future time period estimates of 6-8 hrs. Electrical generation 500-1500's KW size range per installation Capacity factor 40%	Yet to be fully understood but generic issues with: Marine mammal collision Risk to marine navigation and associated pollution risks (less if deeply submerged Changes in sediment transportation patterns Underwater cabling: -Seabed and habitat disturbance -Electromagnetic interactions with elasmobranchs	Based upon estimates rather than track record: Early full scale prototypes 11,000 to 26,000 \$/kW 63-72 c/KWh Early production models 7,000 \$/kW approx. 29 c/KWh
Technology b	Point Absorber: Conversion of wave heave motion into mechanical relative displacement between floating	Demonstrated at up to 100(?)KW power level in open sea	Intermittent energy source. Forecast ability better than wind, but good reliability only based on future time	Yet to be fully understood but generic issues with: Marine mammal collision Risk to marine navigation	as above

Resource / Technology	Technology Description	Technology Status	Type of Application - size - heat / electricity - peak / base / capacity	Environmental Effects	Costs*
	buoy on sea surface and other reference point. Variety of PTO options including; Fluid pumping (water or oil) Hose Pump Direct drive linear generator		period estimates of 6-8 hrs. Electrical generation + high pressure water pumping/desalination opportunities 100's KW size range per installation Capacity factor 40%	and associated pollution risks (less if deeply submerged) Changes in sediment transportation patterns Underwater cabling -Seabed and habitat disturbance -Electromagnetic interactions with elasmobranchs	
Technology c	Overtopping: Use of wall to focus wave energy into central location. Waves of certain size break over head wall and fill floating reservoir. Low head hydro turbines in floor of reservoir are connected to rotary electrical generator(s)	Demonstrated at up to 100KW level in open sea. Advance plans in place to deploy MW size device in 2007	Intermittent energy source. Forecast ability better than wind, but good reliability only based on future time period estimates of 6-8 hrs. Electrical generation 10's MW size range per installation Capacity factor 40%	Yet to be fully understood but generic issues with: Large mammal collision Risk to marine navigation and associated pollution risks (less if deeply submerged) Changes in sediment transportation patterns Underwater cabling -Seabed and habitat disturbance -Electromagnetic interactions with elasmobranchs	as above
Technology d	Attenuator: Semi-submerged, articulated structure of sections linked by hinged joints. The wave motion on these joints is resisted by hydraulic rams, which pump high-pressure oil through hydraulic motors which	750KW pre production prototype deployed. Commercial order placed for several devices for Portuguese deployment 2006.	Intermittent energy source. Forecast ability better than wind, but good reliability only based on future time period estimates of 6-8 hrs. Electrical generation 10's MW size range	Yet to be fully understood but generic issues with: Marine mammal collision Risk to marine navigation and associated pollution risks (less if deeply submerged)	as above

Resource / Technology	Technology Description	Technology Status	Type of Application - size - heat / electricity - peak / base / capacity	Environmental Effects	Costs*
	drive electrical generators		1-2MW size range per installation Capacity factor 40%	Changes in sediment transportation patterns Underwater cabling -Seabed and habitat disturbance -Electromagnetic interactions with elasmobranchs	

\*Sources: General experience of SKM and NaREC gained in a number of different renewable energy projects  
EHMS 2005 for solar thermal costs



## 4. Renewable Energy Potential

### 4.1 Introduction

This section reviews the existing and potential future renewable energy potential of the Manawatu-Wanganui Region, looking in turn at wind, solar, hydro, biomass, geothermal and marine energy.

### 4.2 Wind

#### 4.2.1 Wind Resource

Overall, New Zealand has good wind resource due to its location in the roaring forties, but wind speeds vary considerably around the country (Figure 10). Both wind resource maps in Figure 10 have limited accuracy but provide a good indication of high wind areas. The NIWA map is derived from met station data whereas the Canterbury map is based on weather model data.

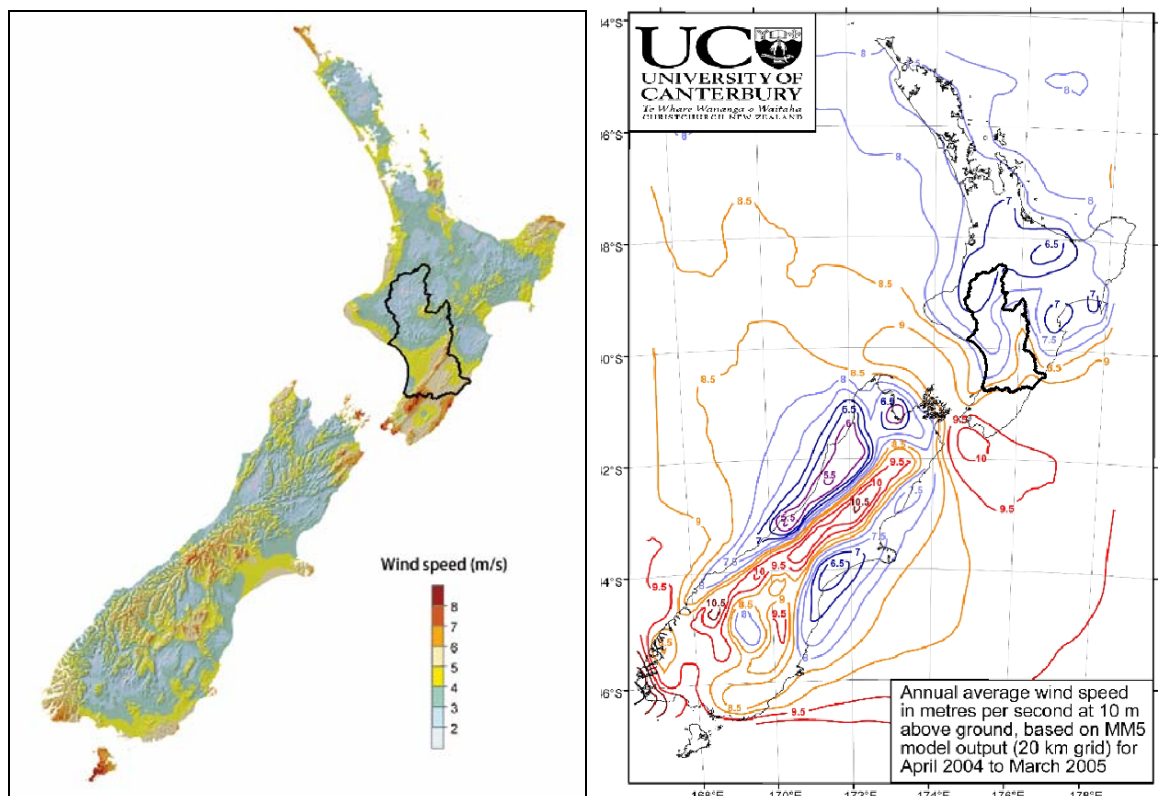

■ **Figure 10 Median and average wind speed at 10 m height (NIWA 2005a, Canterbury 2005)**



The wind speeds in the Manawatu-Wanganui region are among the highest in the country. The southern part of the North Island is the windiest area in New Zealand. Average wind speeds in the Tararua Ranges are about 10-11 m/s.

Earlier studies (EECA & CAE 1996, EECA 2001a) identified three potential areas in the Manawatu-Wanganui region with sufficient wind speeds: the Tararua Ranges (Manawatu Gorge), the northern part of the west coast and east coast hills/coastline. The wind speeds were estimated to be 10, 7 and 8 m/s at 50 m height, respectively.

Based on the more recently published wind maps it is estimated that there are also a number of elevated and exposed locations in the Tararua District with wind speeds of around 8-9 m/s at 60-80 m height (this is the hub height range for modern large wind turbines). Most of the terrain is very complex, which requires onsite wind measurements to assess the wind conditions on a project by project basis.

Furthermore, it is estimated that elevated and exposed areas on the central plateau around Waiouru have sufficient wind speeds (around 8 m/s).

#### **4.2.2 Potential Electricity Generation from Wind**

Wind power generation has become a significant contributor to electricity generation in many regions around the world (especially Europe and US). There is currently 60,000 MW of wind power installed worldwide. Germany alone has almost 18,000 installed wind turbines with a total capacity of around 18,500 MW. The development of wind power in New Zealand had been delayed for many years because of very low electricity prices, which made it uneconomic to install wind turbines. Rising electricity prices during the last few years have changed this, and wind farms are now competitive with other forms of electricity generation. New Zealand's total installed wind power capacity of 170 MW is still very low though when compared internationally.

There are currently two wind farms in the Manawatu-Wanganui region:

- Tararua I&II, 68 MW
- Te Apiti, 90.75 MW

A further two are currently under construction:

- Tararua III, 93 MW
- Te Rere Hau, 48.5 MW

Some wind farm developers have publicly announced further plans and projects:

- Scotts Road
- Turitea



- Shannon
- Barrells Road

It is difficult to accurately estimate the wind power potential for the Manawatu-Wanganui region. SKM has spoken to a number of wind power developers active in the region. Due to the highly competitive market situation, they were not able to provide project locations or planned capacities (other than the above). Those projects will only be made public once all landowner agreements have been signed and when there is high confidence about the viability of the project.

It is not only the wind speed that determines suitable areas, but a range of other factors including location of important natural features, proximity to population, site availability, topography, access and distance to electricity network or grid.

Figure 11 shows areas that will require careful and sensitive planning when proposing wind farms. Native forest and Department of Conservation (DoC) land can lengthen and complicate the consent process. Most of these areas are currently perceived as not suitable for wind farms. It can be seen that it may be difficult to obtain consents for some elevated and exposed areas with likely high wind speeds. However, it is assumed suitability will be assessed on a case by case basis, and that wind farm development on DoC land will be restricted rather than prohibited. For example, one of the planned wind farms, Turitea, is on DoC land and will require some clearance of native scrub (PNCC, 2006). Palmerston North City Council is currently proposing to amend the Turitea Reserve Management Plan to allow wind farm development on this particular reserve.

The accumulation of wind farms can potentially lead to cumulative environmental effects (mainly visual). The wind farms in the Manawatu-Wanganui region are currently concentrated on the Tararua Ranges and support for a wind farm is likely to decrease with every new wind farm.

Furthermore, the accumulation of wind farms in one area puts the transmission grid under more strain with concurrent variations in the power output of the wind farms. The system operator might have to request that wind farms are operated and controlled so that the power output variations are kept to a minimum.

Approximately five to seven wind farms could potentially be developed based on an initial screening of the region taking into account wind resource, topography, population density, distance to grid, accessibility and environmental factors (native forest and DoC land). Maps 2 through 4 in Appendix B show topography, native forest/DoC land and infrastructure in more detail than is shown in Figure 11.

The development of additional wind farms in the Manawatu-Wanganui region is likely to cause some controversy as it has done before and also does in other regions of the country.



*If carefully planned, approximately 200-400 MW of additional wind capacity could be installed over a number of years with environmental impacts that were broadly acceptable to local communities.* This excludes the existing 160 MW and the 140 MW under construction. The technically available potential is much larger.

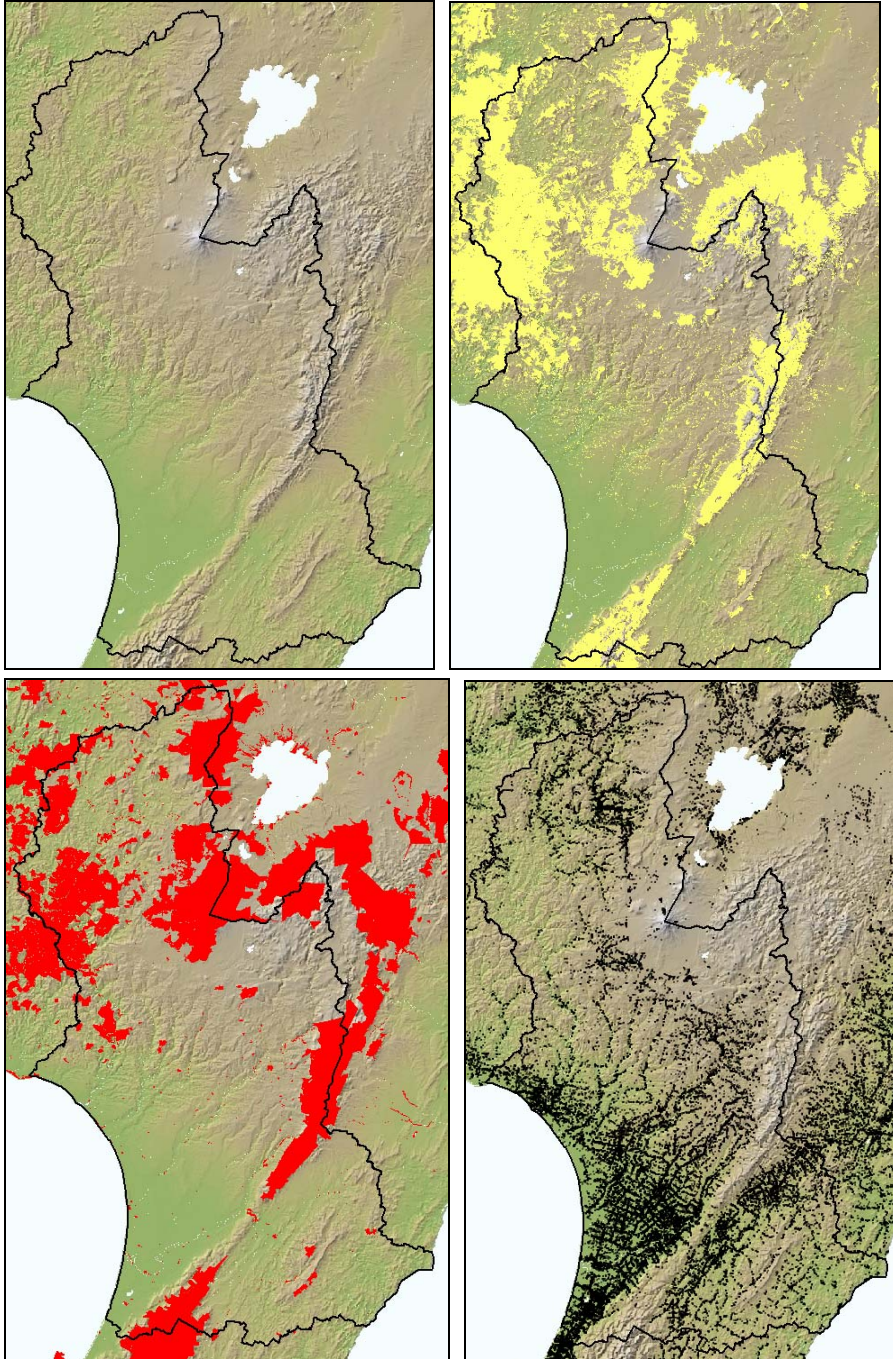

■ **Figure 11 Elevation, native forest (yellow), Department of Conservation land (red) and buildings (black dots)**



The development of wind farms in the Manawatu-Wanganui region needs also to be looked at in a nationwide context. Due to the intermittent nature of wind power there is a limit to how much wind power can be connected to the national grid. A recent study investigated the wind power integration limit (Energy Link & MWH NZ 2005). It was found that 20% of the nation's annual electricity consumption could potentially be met by wind generation. This leads to a potential wind power capacity of around 2,000 MW (based on today's consumption). There is currently only 170 MW of wind power installed in NZ but a number of large projects totalling more than 1,000 MW are under way or are being planned.

Small scale wind turbines (<10 kW), which are used for remote power supply, can successfully be operated in areas with lower wind speeds also. However, the lower hub heights (approx. 10-20 m) of these smaller turbines means more care needs to be taken when siting near local obstacles (*e.g.* trees and buildings). Small scale wind turbines will not play a significant role in future electricity generation, but they can become important for remote farms and settlements.

### 4.3 Solar

#### 4.3.1 Solar Resource in the Manawatu-Wanganui Region

Solar radiation across New Zealand is similar to that at many sites in Australia and higher than most areas in Europe (Table 4). Average solar radiation for the Manawatu-Wanganui region is approximately 1400 kWh/m<sup>2</sup>/yr, with values ranging from 1200 to 1500 kWh/m<sup>2</sup>/yr for Ruapehu and Ohakea respectively (Figure 12).

- **Table 4 Typical values of total global solar radiation for several sites (EECA 2001b, NIWA 2006a)**

	MJ/m <sup>2</sup> /yr	kWh/m <sup>2</sup> /yr
<b>Sydney</b>	6150	1708
<b>Melbourne</b>	5302	1473
<b>Kaitaia</b>	5288	1469
<b>Palmerston North</b>	<b>4949</b>	<b>1375</b>
<b>Gisborne</b>	5386	1497
<b>Paraparaumu</b>	5035	1403
<b>Christchurch</b>	4898	1360
<b>Invercargill</b>	4652	1292
<b>Germany</b>	3609	1003



The solar radiation varies greatly over the year. Figure 13 shows the variation at 5 weather stations in the region. The given radiation data is valid for horizontal surfaces. The gain of solar systems can be easily enhanced by tilting the system towards north. Optimum tilting angle is the value of the latitude of the site. For example, an increase in the performance of a solar system in Palmerston North of around 11% can be achieved by tilting the system by 40° towards north.

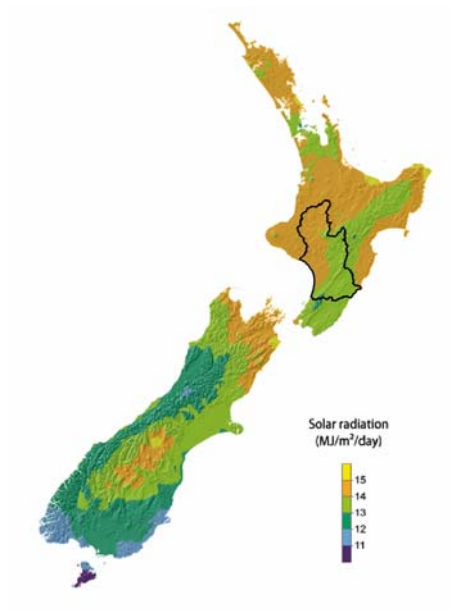

■ **Figure 12 Solar radiation distribution (NIWA 2005b)**

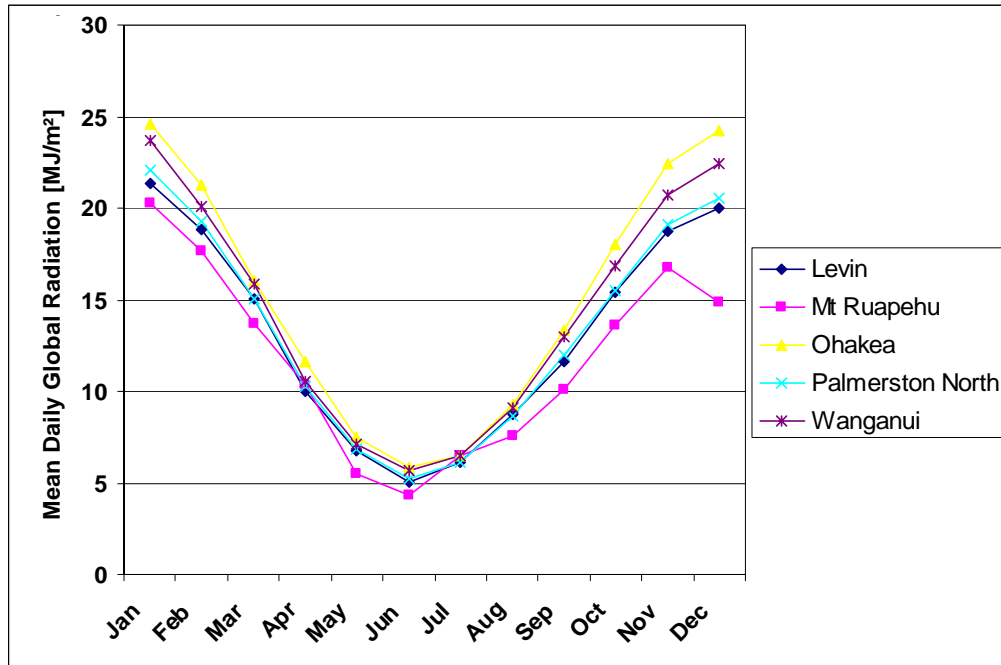

■ **Figure 13 Monthly variation of solar radiation (NIWA 2006a)**

#### 4.3.2 Potential for Solar Thermal

Households account for 37% of electricity demand in the Manawatu-Wanganui Region (EECA, 2004). Of this, about one third is usually for water heating (BRANZ 2004). A standard solar thermal system can produce around 55% of a household’s water heating. Hence, the installation of solar thermal technologies has the potential to address some of the regions overall supply issues.

Solar thermal systems are most economic when installed in new buildings. Population growth in the Manawatu-Wanganui Region has been a moderate 0.6% for the 2001 to 2006 period (Statistics NZ 2006). The number of occupied dwellings increased by approximately 2,000, with largest growth occurring in the Manawatu District and Palmerston North City. The areas with high demand in new housing and are best suited for promotion and installation of solar thermal systems.

Overall, *there is potential for a substantial increase in the uptake of solar thermal use in the Manawatu-Wanganui region.*

#### 4.3.3 Potential for Solar Photovoltaic

The biggest barrier for the large scale uptake of PV is the high cost of the technology. Consequently, uptake has predominantly been for remote power supplies, enthusiast users and commercial developments where renewable energy has additional value as a corporate strategy or image statement. In summary, *the current high costs of solar photovoltaic means that large scale*



*grid connected uptake in the region is unlikely, however small scale applications, particularly for remote power supply are expected to become more popular.*

#### **4.3.4 Potential for Passive Solar Building Design**

Solar space heating can significantly reduce the amount of energy use in new buildings. With solar space heating, the building is designed to maximise the absorption of solar energy. This can be applied to any building regardless of size or use (domestic/commercial). The building design considers building placement and orientation on the site and design features to capture, store and release solar energy in the building. Solar building design not only reduces the energy use, but it also can reduce moisture and condensation, improve sound insulation and provide a generally more comfortable and healthy living environment.

### **4.4 Hydro**

#### **4.4.1 Previous Hydropower Capacity Studies**

The potential for developing the hydro-electric potential of New Zealand has been the subject of study for more than 100 years, the milestone reports being:

- 1) **The Hay Report (1904):** The earliest full assessment of New Zealand's hydro-electric resource was conducted in 1904, when North and South Island reports were tabled in the House of Representatives. Nearly all of the schemes which have so far been developed were identified in these original reports.
- 2) **Ministry of Works and Development (1982):** MWD undertook a comprehensive assessment of the country's small and medium scale hydropower potential in the period 1978 to 1985, establishing a consistent assessment methodology to look for sites with a potential installed capacity in the range 500 kW to 50 MW assuming a typical plant factor of around 50%. The work involved a review of maps, gauged river flows and topography to identify opportunities for harnessing water power. Local features of the most promising sites were then assessed and preliminary concepts were devised. Tonkin and Taylor (1982) made an assessment of potential in the region comprising the catchments of Wanganui, Whangaehu, Turakina and Rangitikei rivers and the catchments of the Manawatu River east of the Manawatu Gorge and its tributaries – Pohangina and Oroua river systems. They estimated a potential installed capacity of around 450 MW from approximately 52 sites. The potential schemes including the ones identified in Works (1990) and their scheme parameters, where available, are tabulated by catchment area in Appendix A and their locations are shown on Map 1 (Appendix B).
- 3) **WORKS (1990):** Another nationwide survey was undertaken by WORKS which summarised the large schemes (>10 MW) from previous studies and went on to consider the practicability of some of the major schemes including some very large opportunities in South Island. This



study concluded that the Manawatu-Wanganui region had the potential for an additional 930 MW from 22 schemes. It identified 415 MW from the Wanganui River, of which 400 MW would be from two major schemes. However it also recognized that there might be considerable opposition to any development on the Wanganui River because of its high recreational, cultural and environmental value. The other significant potential developments identified were 330 MW on the Rangitikei River, with 310 MW coming from a cascade type scheme with nine dams. Other potential developments are three schemes on the Whangaehu River (140 MW), three schemes on Manawatu (totalling 35 MW) and one 10 MW scheme on the Turakina River.

- 4) **Ministry of Economic Development (2004):** In their 'Waters of National Importance' report, East Harbour Management Services considered the hydro-electric resources of New Zealand. A 'publicly known' nationwide future hydropower potential of around 2,500 MW is considered, recognising also that there are possibly a significant number of opportunities not publicly identified. In the Manawatu-Wanganui region, it identified seven schemes with a total potential capacity of 129 MW in the 'high' and 'medium' confidence category. Of these, five schemes were in the Wanganui catchment (110 MW), one in the Rangitikei (9 MW) and one in the Manawatu (10 MW). The total is equivalent to 5% of the national hydro potential.
- 5) **EECA Renewable Energy Industry Status Report (2005):** On behalf of EECA, East Harbour Management Services went on to report on the nationwide potential for additional renewable power generation. On a national basis, the report estimated an additional annual hydro potential of some 4,260 GWh (equivalent around 900 MW with a typical plant factor of 50%). Cost estimates were based on escalating the MWD data from the 1980's. In the Manawatu-Wanganui region, eight schemes below 16c/kWh (@10% weighted average cost of capital (WACC)) were considered having a combined capacity of 144 MW at the medium confidence level.
- 6) **Ministry of Economic Development (2005):** East Harbour Management Services reported on the overall scope and cost ranges for generating electricity and heat from renewables. In the Manawatu-Wanganui region, eight hydro schemes were identified with total installed capacity of 144 MW at the medium confidence level and at 16c/kWh (@10% weighted average cost of capital (WACC)).
- 7) **Electricity Commission (2005):** As part of the Electricity Commission's Statement of Opportunities a report was compiled by Parsons Brinckerhoff which provided a summary of all previously identified schemes – large and small. The report included cost estimates escalated from the MED report and developed ranges of possible cost (on a theoretical basis only) for schemes not previously estimated. The report summarised the schemes from previous references.



#### 4.4.2 Background

The region contains two of the North Island's largest rivers, the Wanganui and Rangitikei rivers. The catchment areas of the Wanganui and Rangitikei have widely varying topography – from the rugged slopes of Mt Ruapehu, the Kaimanawa Ranges, and the volcanic plateau around Waiouru to flat and gently rolling pasture land around and inland from the coast. The rainfall in the area also varies significantly, ranging from over 5,000 mm on Mt Ruapehu to 900 mm at the coast. There is seasonal snow in areas above 1,400 m. The major rivers are the Wanganui, Rangitikei and Wangaehu. The Wanganui river is around 305 km long, and with a mean flow of 200 m<sup>3</sup>/s at the river mouth, is the second largest river in North Island. The Rangitikei River has a mean flow of around 80 m<sup>3</sup>/s and is the sixth largest river in North Island. A proportion of the flow from the Wanganui River is diverted through the Tongariro power scheme to the Waikato hydro system.

The Manawatu catchment covers around 5,946 km<sup>2</sup>, draining the central east coast of the North Island. The mean annual rainfall in the region varies from 6,000 mm in the northern Tararua Ranges to 870 mm on the coast south of Foxton, with the majority of the area experiencing between 1,000 mm and 2,000 mm of annual rainfall.

For identifying the potential hydropower schemes in the region, the area has been divided into four major catchment areas on the basis of the major river systems, and one smaller catchment that includes Akitio and Owhanga Rivers and other smaller rivers originating in the Puketoi Range and flowing east to the Pacific Ocean.

The major rivers and lakes in these catchment areas are given in Table 5.

■ **Table 5 Manawatu – Wanganui Region Catchment Areas, Major Rivers and Lakes**

	<b>Catchment Area</b>	<b>Catchment Area (km<sup>2</sup>)</b>	<b>Major River(s)</b>	<b>Lakes</b>
1.	Wanganui	7,100	Whakapapa, Kakahi, Ongarue, Retaruke, Ohura, Mangapurua, Ruatiti, Tangarakau	
2.	Whangaehu – Turakina		Whangaehu, Turakina	
3.	Rangitikei		Rangitikei, Moawhanga	
4.	Manawatu	5,944 (3,231 in east and 2,713 west of the Manawatu Gorge)	Mangahao, Makuri, Tiraumea, Orua, Pohangina	3 small lakes formed by Mangahao Power Scheme
5.	Akitio-Owahango		Akitio, Owahango	



#### 4.4.3 Developed Hydropower Resources

There are two existing hydroelectric generation schemes in the region, as listed in Table 6.

■ **Table 6 Developed Hydro-Electric Schemes in Manawatu – Wanganui Region**

Catchment Area	Scheme	Scheme Rating (MW)	Year	Owner/Operator
Wanganui	Piriaka	1.55	1924	King Country Energy
Manawatu	Mangahao Power Station	38	1924, refurbished in 1994	Todd Energy / King Country Energy
	TOTAL	<b>39.55</b>		

#### 4.4.4 The Market for Hydropower Development

Since the cornerstone MWD (1982) report, the electricity industry in New Zealand has undergone significant changes. Different scheme design drivers apply today, affecting the way that the originally conceived schemes would be viewed as investment opportunities, in particular the need for a developer to keep to a minimum the risks and uncertainties associated with environmental effects, ground risk and hydrology.

Though hydropower technology is relatively mature, some technological improvements have been made in civil works, and plant construction and equipment efficiency. For example, the use of a tunnel boring machine (TBM) might nowadays allow a dam to be avoided and for an alternative scheme layout to be considered. Additional infrastructural development such as new roads and transmission/distribution lines may have helped to improve project economics, though conversely, more onerous consenting changes and environmental requirements may make some projects less feasible.

#### 4.4.5 Possible Future Hydropower Potential

The potential identified in the region are discussed in the following sections.

##### Wanganui Catchment

The major potential on the Wanganui River that has been previously identified are dam and powerhouse schemes at Atene and Retaruke with a combined capacity of around 400 MW. While these options were not investigated further at the time of their identification (because there were cheaper alternate generation sources) they may now prove competitive.

Several potential projects in the 1 MW to 5 MW range have been identified on different reaches of the Wanganui River and its tributaries.

Five schemes were identified on the tributaries of the Wanganui River that flow from Mt Ruapehu; one scheme on Mangatepopo stream and four on the Whakapapa River. Further downstream, the



western diversion of the Tongariro Power Development extracts significant flows from these rivers to Lake Rotoaira, and from there to the Waikato hydro system.

In the middle reaches of the Wanganui River, several sites have been identified that may be able to use the head across steep sections of the river and waterfalls. There are four sites that may have potential on Waimiha/Ongarue Rivers and the Manganui-a-te-ao River.

In the lower reaches, the economics of potential hydropower schemes are likely to be affected by the lack of major road access and nearby transmission lines to connect to.

### **Whangaehu-Turakina Catchment**

The region includes the area drained by the Whangaehu River and the Turakina River and their tributaries.

Several major potential developments have been previously identified to be possible on the Whangaehu River – three schemes in the range of 20 MW to 25 MW and another scheme of around 40 MW. Also the major tributaries of the Whangaehu may have significant potential. A large hydroelectric scheme of 60 MW capacity that would have a dam on the Mangawhero River in the vicinity of Oreore and a tunnel to a powerhouse on the Wanganui River have been mentioned as possible in earlier studies. Others that were identified are four schemes on Mangawhero and Tokiahuru Rivers and a possible diversion of upper Mangawhero tributaries into neighbouring Orautoha stream.

The Turakina River has its headwaters near Waiouru, and although a small river is quite long. The Turakina River itself was assessed to have little potential for hydropower because of its low gradient and relatively low rainfall over the catchment. A 10 MW scheme was considered possible by diverting it to the Whangaehu River through a 14 km long tunnel.

### **Rangitikei Catchment**

The headwaters of the Rangitikei are in the Kaimanawa Mountains. The Rangitikei River has an existing Water Conservation Order that may affect the development of the hydro schemes on it.

A cascade type scheme that consists of nine dam and powerhouse schemes was mentioned previously which has a combined capacity of around 310 MW. Another study conducted in 1985 assessed the viability of the potential 'diversion' type schemes in the region. This type of scheme in the Kaimanawa and Ruahine Ranges would be affected by access difficulties and transmission line requirements. The schemes considered to show the highest potential were two schemes on Hautapu River and one scheme each on upper Rangitikei River, Kawhatau and the Whakaurekou Rivers.



### **Manawatu Catchment**

Potential in the western reaches of the Manawatu River including its major tributaries Oroua and Pohangina has been studied previously. The tributaries originate on the western slopes of the Ruahine Ranges and flow south to meet the Manawatu River. Several schemes have been identified in the headwater regions of the tributaries as having some potential, while recognising that their development would face difficult geological and topographical conditions resulting from the proximity of the area to the main regional fault zone. Another potential scheme that has been considered is a low head scheme downstream of the Manawatu Gorge with a potential of around 15 MW.

The upgrade of the existing Mangahao power station by diverting water from the Ruamahanga River from the adjacent Wellington region is deemed possible and is estimated to have a capacity of around 10 MW.

### **Akitio-Owahango Catchment**

There are several rivers that flow east from the Puketoi Range to the coast – the Owahango River and the Akitio River. These rivers originate on the eastern slopes of the Puketoi range and meander predominantly eastwards over low hilly areas before flowing to the coast. There may be potential for micro and mini hydro schemes at localised falls in the rivers.

#### **4.4.6 Other Possible Hydropower Options**

Beyond the potential for conventional new hydro installations (developing head and diverting flow to generate electrical power by conventional water turbines), other means of increasing the contribution of hydropower include:

#### **Rehabilitation and/or Uprating of Existing Plant**

Modernisation and refurbishment of the water turbines and generators at existing hydropower schemes can typically realise an increase in output of 10 to 20% and/or (depending on their relative value in the power market) additional energy across the operating envelope of typically 2 or 3%.

#### **Alternative Technologies**

There are some experimental technologies that in the future may become viable to harness hydro potential. Helical turbines for example (for ‘ultra low head’ applications) are a reaction crossflow machine, developed between 1993 and 1995 at Northeastern University in Massachusetts. The turbine operates in the streamflow and extracts energy from the stream velocity. Steep reaches in rivers with water velocities  $>1.0$  m/s can provide potential sites for machines in series.

Other new technologies evolving, intended to reduce the complexities and capital costs of small hydro schemes, and for ‘modular’ applications, include siphon type turbines, variable speed and



PMG generators and plastic pipelines. For the very small schemes, waterwheels with gearboxes or belt-drives can still have a place.

#### 4.4.7 Summary

In summary:

- Two dam-powerhouse schemes with installed capacity of 400 MW on the Wanganui River, around 8 medium scale schemes with potential installed capacity of around 283 MW and a cascade system with nine dam/powerhouse schemes on the Rangitikei River with a combined capacity of 310 MW have been identified as potential in the region.
- Approximately 43 ‘mini’ or ‘small’ scale projects are believed to be possible in the region with a combined capacity of approximately 196 MW.
- Among the possible schemes, around 24 schemes with a total installed capacity of around 614 MW appear to be outside the Department of Conservation land and native forest areas.
- For the reasons of the dispersed nature of the resource, technical and regulatory complexities, proportionally high development overheads, landowner issues etc, the ‘micro’ hydro potential of the area has never been identified.

Additional potential hydro sites can be identified through the use of modern GIS techniques using updated geographical information. GIS techniques can be used to isolate reaches of rivers with reasonable slopes and to estimate flows to determine the theoretical energy potential of the site. This will be especially relevant in determining small, mini and micro hydro sites where this type of screening approach would potentially be very useful.

*The installed hydro capacity within the Manawatu-Wanganui Region is almost 40 MW. The remaining hydro potential is about 400 MW in two large scale projects, 283 MW in medium scale projects, 310 MW from a cascade project with nine schemes, and 196 MW in mini, small, and medium scale projects. The micro hydro potential has not been assessed. Altogether medium, small and mini schemes with a combined potential of 614 MW appear to be outside the Department of Conservation land and Native Forest areas.*

## 4.5 Biomass

### 4.5.1 Biomass Resource in Manawatu-Wanganui Region

The resources for the production and use of biomass as a renewable energy resource include agricultural crops, dairy and livestock farming, forestry and the residues associated with production and processing of these.



The Manawatu-Wanganui region is large and agriculturally very diverse, including the Rangitikei, Ruapehu and Tararua districts as well as Manawatu and Wanganui. The region includes areas of generally fertile soils and well-distributed rainfall that are suitable for cropping, although energy cropping would be at the expense of the currently dominant pastoral farming. The Horowhenua District has areas with climate and soils particularly suitable for intensive cropping and could become a source of crop-derived biomass. As much as 300,000 ha could be considered suitable for energy cropping (EnConsult, 1981), which compares with a similar area in the Waikato Region and 525,000 ha in Canterbury.

Manawatu-Wanganui's agriculture is characterised by livestock production, particularly dairy, and areas of more intensive agriculture. Much of the region is likely to remain a pastoral farming area, as indicated in the regional land use map (Figure 14).

#### **4.5.1.1 Agricultural Crops for Energy**

A wide range of crops can be grown in New Zealand that are suitable for renewable energy production, including both thermal and electrical energy and transport fuels. These include:

- grain crops - maize, wheat, oats and barley
- root crops - fodder beet, sugar beet, potatoes
- oil-seed crops - rape, linseed,
- herbaceous crops – kale, sweet sorghum, grass and lucerne

New Zealand produces around 950,000 t/year of grain and seed crops (Statistics NZ, 2002) with barley, wheat and maize grain being the leading components. Peas and other pulses contribute an additional 33,000 t/year. The starches in grains and pulses are readily converted to sugars and then fermented to produce ethanol. These crops are the basis of the very large “corn-based” fuel alcohol industry in the US. Blends of up to 10% ethanol in gasoline, known as “gasohol”, are widely available throughout much of the US.

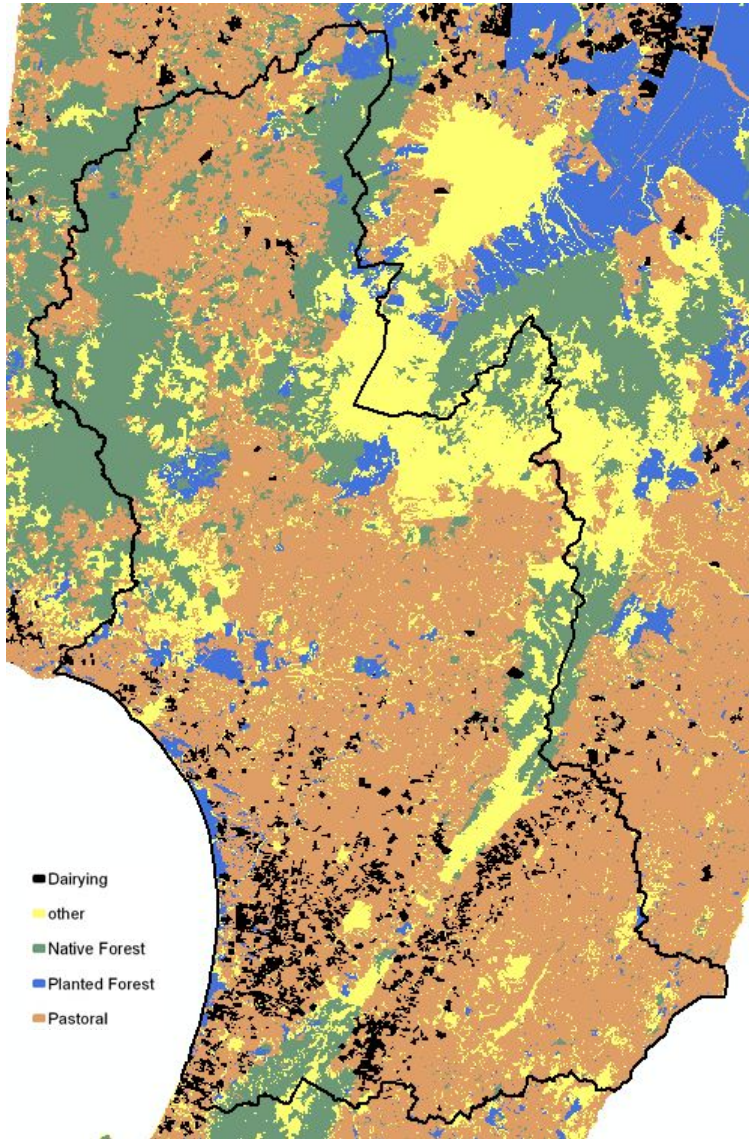

■ **Figure 14 Manawatu-Wanganui land use map**

Oil seed production in New Zealand is much smaller, at around 5000 t/year, and also highly variable. Most of the oil-seed production is based in the lower South Island. Vegetable oils are attracting increasing interest as a raw material for the production of transport fuels, especially “biodiesel”.

The Manawatu-Wanganui region is already a substantial producer of grains, including 24,000 t/year of maize grains, 23,000 t/year of barley and 6,600 t/year of wheat in 2002 (Statistics NZ, 2005). This production was derived from only 9,500 ha, indicating that the level of production could be increased significantly using just a portion of the available 300,000 ha of arable land in



the region. The current level of grains production (around 54,000 t/year of maize, barley and wheat) could provide for the manufacture of 27 ML/year of ethanol.

The climate and soils of the Manawatu-Wanganui region are well suited to root crops and somewhat higher yields, averaging around 10 ODt/ha, may be achieved with beet crops in particular, i.e. sugar beet and fodder beet. The manufacture of transport fuel from beet crops grown on the currently cropped 9,500 ha could deliver around 41 ML/year of ethanol.

Oil seed cultivation is not common in the Manawatu-Wanganui, presumably because of production economics rather than an adverse climate or unsuitable soils. Yields of oil-seed rape in Southland are typically in the order of 1.8 ODt/ha, equivalent to nearly 700 L/ha yr for biodiesel from this crop.

#### **4.5.1.2 Forestry and Wood Processing Residues**

Forestry has the potential to be a very major supplier of biomass for several types of renewable energy. New Zealand has around 1.75 million hectares of planted production forestry which is being harvested at a rate of 50,000 ha/year, producing around 22 million cubic metres of timber.

At April 2004 the Manawatu-Wanganui region included 127,700 ha of planted production forestry with an area-weighted average age of around 13 years (MAF, 2005). Nearly 40,000 ha of this area is classified as “unpruned and without production thinning”, indicating that it would be valued at the lower end of the scale, suitable for pulping, fibre-based manufacture (MDF *etc.*) or for energy.

Production of liquid fuels from just the “unpruned and without production thinning” forestry resource in the Manawatu-Wanganui region, without recovery of the harvesting residues, could result in around 135 ML/year of methanol and over 60 ML/year of ethanol. Use of this material in a “dendro-thermal” power plant for electrical generation could support a generation plant capacity of around 30 MW<sub>e</sub> and generate some 250 GWh/year.

#### **4.5.1.3 Short Rotation Woody Biomass for Energy**

In some countries where areas have been identified as suitable for the supply of woody-biomass (and where generation from renewables is subsidised) it is increasingly common to find the cultivation of fast-growing, coppicing species such as willow, poplar *etc.* This is usually grown as fuel for dendro-thermal power plants, but may also be used as a cellulose feedstock for the production of ethanol via hydrolysis, fermentation and distillation.

Small-scale cultivation trials of *Salix* (shrub willow) are currently underway in parts of New Zealand (although none in the Manawatu-Wanganui Region that we are aware of) with the expectation that the production would form the basis of fuel ethanol and possibly bio-polymer



industries. The suitability of such fast-growing and machine-harvestable sources of woody biomass, and the relative economics of production, will not be known for several years.

#### **4.5.1.4 Livestock Farming – Dairy and Meat**

As indicated in Figure 14, the Manawatu-Wanganui region includes large areas of pastoral farming.

##### **Dairy processing residues**

Manawatu-Wanganui is a significant dairy region in New Zealand with around 1,700 dairy farms and an aggregate dairy herd of more than 400,000. The region produces around 1,800 ML of raw milk per year and much of the milk from this region is processed at the Whareroa site in south Taranaki with relatively smaller amounts processed at Pahiatua (cheese) and Longburn (milk protein concentrate and casein). Products such as cheese and protein concentrate result in lactose-containing whey, but virtually all of the lactose streams from the Pahiatua and Longburn sites is processed to lactose at the Kapuni site in Taranaki.

Residual lactose streams of appropriate quality may be fermented and the ethanol recovered by distillation. Ethanol is produced at three sites in the Bay of Plenty and the Waikato, but none within the Manawatu-Wanganui region.

Dilute dairy effluent streams, some containing residual biodegradable materials, may also be amenable to anaerobic digestion, producing biogas. Although of relatively low calorific value, this biogas may be used directly for heat-raising or electrical generation. No sites in Manawatu-Wanganui region are known to be recovering biogas from anaerobic digestion of effluent.

The remaining effluent streams, some of which may contain lactose, but for which recovery or processing are regarded as uneconomic, are disposed of to local waterways or spray-irrigated onto adjacent farms.

##### **Meat processing by-products**

New Zealand produces almost 150,000 t/year of animal fats (*i.e.* tallow) from meat processing plants. In past years much of New Zealand's tallow production was used locally for soap manufacture, but most is now exported. Tallow may be used in the manufacture of biodiesel by way of a relatively simple esterification process.

Of New Zealand's 150,000 t of tallow produced in the year ending March 2006 (J O'Connell, pers. comm., Statistics New Zealand), some 147,800 t was exported. Of this tonnage, more than 400 t was edible grade tallow with an average value of around NZ\$1,300/t FOB. The balance of nearly 147,400 t consisted of inedible grades with an average value of NZ\$500/t FOB.



There are several meat processing plants and abattoirs in the Manawatu-Wanganui region, many of which have rendering plants to recover tallow. Accurate figures are difficult to obtain, but 51,000 t of tallow was exported through Napier Port and a further 33,000 t through Westgate Port, New Plymouth, in the year to March 2006.

### **Municipal Solid Waste**

Municipal solid waste (MSW) is included in this investigation and report on the basis that a proportion, the organic portion in particular, may be regarded as a renewable resource. The population of around 220,000 in the Manawatu-Wanganui region generates around 126,000 t/year of waste (Horizons, 2006), of which around two thirds is organic. The remainder is principally glass, metals and building materials.

### **Anaerobic digestion**

The anaerobic digestion of wet organic wastes (other than plastics) produces biogas, typically a mixture of methane and carbon dioxide with the methane content ranging from about 45% to 60% (CAE, 1992), sometimes as high as 80% by volume (dry basis) (East Harbour, 2005) and a calorific value between 12 and 30 MJ/m<sup>3</sup>.

No New Zealand councils or waste disposal contractors are known to be using bacterial digestion processes for disposal of solid wastes, although the technology is available.

Anaerobic digestion of MSW occurs naturally in landfills where it is a by-product of bacterial action. Relatively few of NZ's older landfill facilities were set up specifically to produce biogas, to contain it or to provide for its recovery and use. Although a few of the older landfill facilities have been developed for landfill gas production, the recovery rates are modest and much of the methane is lost to the atmosphere.

As older landfill facilities are closed, however, the newer and larger landfills are required to comply with the National Environmental Standard which was introduced in 2004. Under this standard, there must be provision to destroy the methane, either by flaring the gas or using it as an energy source.

### **Combustion**

Waste combustion is widely used in many other parts of the world, Europe in particular, where landfill disposal of waste is becoming increasingly unacceptable.

Of the more than 240,000 t/year of MSW generated in the Manawatu-Wanganui region, over 80,000 t/year is combustible material with an average calorific value of around 10 MJ/kg. Despite the relatively low calorific value, combustion of this material would produce around 45 GWh/year of electricity.



#### **4.5.1.5 Sewage**

Domestic sewage and liquid industrial wastes are collected from almost all municipal areas and reticulated to central plants for treatment and disposal. Typical quantities of domestic wastewater amount to 200 L/person-day, equivalent to a volumetric flowrate of 15,000 m<sup>3</sup>/day for the regions' largest city, Palmerston North. Effluent from sewage treatment plants is currently discharged to streams and rivers (Horizons Regional Council, 2005).

Total (dissolved and suspended) solids in the wastewater are expected to be in the range of 700 to 1000 mg/L, amounting to as much as 15 t/day of total solids.

#### **Anaerobic digestion**

Treatment of sewage typically involves a flocculation and sedimentation stage to increase the solids concentration and then sludge digestion by aerobic and/or anaerobic processes. Anaerobic digestion produces between 0.75 and 1.12 m<sup>3</sup> of biogas for every kg of volatile sewage solids destroyed, amounting to as much as 15,000 m<sup>3</sup>/day for Palmerston North City. This biogas will have a methane content of between 65 and 70%, by volume.

#### **Sewage sludge drying and combustion**

Sewage solids have been segregated, dried and burnt for over 100 years and modern sewage treatment plants around the world are routinely disposing of sewage solids in this manner. Where sewage solids are recovered from treatment plants in New Zealand they are usually disposed of to landfill. New Plymouth and Upper Hutt are believed to be the only two cities in New Zealand where sludge drying and alternative disposal options are currently available. Sewage sludge drying and combustion trials are understood to be underway in both Hamilton and Auckland with the objective of reducing the high costs of transport and landfill disposal.

Combustible solid recovered from digested sewage sludge is expected to have a calorific value of around 16 MJ/kg (bone dry basis). Despite the apparently high calorific value, the net recoverable energy from the combustion of sewage solids is relatively low, mainly due to the high energy demand associated with drying, sterilisation of the emissions and odour control.

#### **4.5.2 Technology**

##### **4.5.2.1 Transport Biofuels**

A range of transport fuels may be produced from biomass sources. These include:

- Biodiesel – from oil-seed crops, oil-bearing crops such as *jatropha*, and animal fats, via transesterification



- Ethanol – via direct fermentation from grains and root crops as well as via hydrolysis and fermentation from cellulosic material such as wood, straw *etc.*
- Methanol – via gasification of almost all biomass and catalytic re-combination of the resulting synthesis gas
- Biogas – via anaerobic digestion of almost all biomass
- Pyrolysis oil - by the pyrolysis of biomass material and the subsequent separation and refining of the produced liquid.

### **Biodiesel**

Biodiesel is a clean burning transport fuel produced from renewable resources including oil-seed crops and animal fats. Biodiesel contains no petroleum, but it can be blended at any level with petroleum diesel to create a biodiesel blend that can be used in compression-ignition (diesel) engines with little or no modifications. Biodiesel is simple to manufacture, biodegradable, non-toxic, and is free of sulphur and aromatics.

The technical definition for biodiesel (NZS7500:2005) is “a fuel comprised of mono-alkyl esters of long chain fatty acids derived from vegetable oils or animal fats. Typically these are methyl esters or ethyl esters, however higher alkyl groups can be used.” The New Zealand standard appears to follow the US standards (ASTM D 6751 in particular) reasonably closely.

A biodiesel blend (Bx) is a blend of biodiesel with mineral diesel fuel, where “x” represents the volume percentage of the biodiesel component in the blend. Biodiesel blends in New Zealand are presently limited to no more than 5% biodiesel by volume.

### **Ethanol**

The production of ethanol from agricultural biomass is well developed technology. Very large quantities of ethanol are currently manufactured from cane sugar (cf. Brazil) and grains (cf. the USA) specifically for transport fuels.

Starches in grains and pulses (and even potatoes) are readily converted to glucose and then fermented to produce ethanol. Sugars may be extracted directly from crops such as sugar cane, sugar beet etc. Ethanol is currently produced largely from wheat in Australia (EECA, 2006) and sugar cane is expected to become more widely used also. Sugar cane does not grow well in New Zealand although root crops, such as sugar beet, could be grown in most areas of New Zealand and extraction of the sugar is straightforward.

Cellulose, which is the major component of wood, straw, corn stover etc, may also be converted to pentose sugars by hydrolysis. Much of the early work on the hydrolysis of woody-biomass relied on cooking at high temperature and pressure with a dilute mineral acid. This relatively energy-



intensive process has been partially replaced by enzymatic hydrolysis, which requires expensive enzymes but takes place under less aggressive conditions.

Dilute sugar solutions are fermented using typical brewery technology to produce ethanol. The dilute ethanol solution is usually concentrated to around 94% by distillation. Ethanol must have a very low moisture content if it is to be used for blending with petrol and it is therefore distilled again with a ternary component to produce fuel-grade ethanol

The distillation stage is very energy-intensive and several processes, including membrane separations, are under development.

Bioethanol is the basis of the very large “corn-based” fuel alcohol industry in the US. Blends of up to 10% ethanol in gasoline, known as “gasohol”, are widely available throughout many states.

### **Methanol**

Methanol was originally known as “wood alcohol” as it was obtained by the destructive distillation (similar to pyrolysis) of wood. This process is not used in the manufacture of methanol on an industrial scale. The most common route to methanol is from natural gas via the production of synthesis gas and the catalytic reforming of that to form methanol.

Synthesis gas:  $2\text{CH}_4 + \text{H}_2\text{O} + \text{O}_2 = \text{CO}_2 + \text{CO} + 3\text{H}_2$

Gas shift:  $\text{CO}_2 + \text{H}_2 = \text{CO} + \text{H}_2\text{O}$

Methanol synthesis:  $2\text{H}_2 + \text{CO} = \text{CH}_3\text{OH}$

Synthesis gas may be produced by the combustion of almost any biomass under appropriate conditions. Clean woody-biomass is very well suited to the production of synthesis gas as it has a very low ash content.

Methanol is not being proposed as a transport fuel in New Zealand (EECA, 2006), despite extensive vehicle trials in the 1980’s, but is a component in the manufacture of biodiesel.

### **Pyrolysis Oil**

Many forms of biomass will produce a mixture of hydrocarbon-based liquids and gases when pyrolysed, *i.e.* heated to high temperatures under oxygen-starved conditions. The liquid may be further refined and separated to provide a range of potentially useful streams including fuels, solvents *etc.* The technologies require relatively severe processing conditions, and are at an early stage of development relative to the process routes identified above, and are not discussed further.

### **Biogas**

Biogas is generated as almost any biomass is broken down by biological processes.



#### **4.5.2.2 Electricity generation**

The generation of electrical energy from biomass is widely practised around the world and the technologies and economics are well understood. Biomass – typically woodwaste, grain husks, bagasse or straw – is burned to generate steam which is used to power an electrical generator. The combustors range from simple “dutch ovens”, through reciprocating and vibrating grates, to bubbling and circulating fluid bed boilers. Biomass is also increasingly co-fired with coal in stoker and pulverised-fuel boilers.

We are not aware of any examples of electrical generation based on renewable fuels in the Manawatu-Wanganui region.

#### **4.5.3 Summary of Resource Potential**

Overall, *there is some potential for production of both transport fuels and energy from biomass in Manawatu-Wanganui Region. This comprises about 27 million litres of ethanol per year for transport fuel from grain crops currently grown in the region. In addition, about 60 million litres per year of ethanol or 250 GWh/year of electrical energy from woody biomass derived from low-grade forestry.*

### **4.6 Geothermal**

#### **4.6.1 Power Generation**

The Manawatu-Wanganui region does not contain any of New Zealand’s high temperature geothermal fields, which only occur within the Taupo Volcanic Zone and in Northland. There has been recent volcanic activity on Mt. Ruapehu and at Ohakune (where there are small scoria cones), but neither of these locations are known to host exploitable geothermal resources.

With high temperatures at depth in oil and gas exploration wells, it may be possible to generate electricity (GNS 2006), at least in theory. Elsewhere in the world, power can be generated from geothermal fluids at temperatures as low as 80°C using binary power plant technology, though in New Zealand, power is only generated in binary plants from geothermal fluids at more than 120°C, for economic reasons.

It is necessary to have large volumes of fluid, and not just adequate temperatures, for power generation. Furthermore, that fluid would have to be water, rather than hydrocarbons, since oil (which is found at depths of about 2000 m) will be too cool for power generation, and gas, which is deeper (around 3500-4000 m) and thus hotter, does not have appropriate thermal properties for the extraction of heat. So if there are abandoned deep onshore wells that penetrate an overpressured water-filled aquifer at depth (>4000 m), they could potentially be used for electricity generation.



However, it is more likely that the temperatures and flow rates obtained would be too low for power generation, and would be more appropriately used for direct heat applications.

#### 4.6.2 Direct Use

Low temperature geothermal fluids (<150°C) can be used for a range of direct heat applications, depending on the temperature (Figure 15). Such fluids can be obtained from low temperature geothermal systems, or from deep within the earth. Warm water reaches the surface at springs near Jerusalem, Pipiriki, and in the Ruapehu crater lake (Table 7). To our knowledge, none of these warm water occurrences are put to any use.

Several deep onshore oil and gas exploration wells have been drilled in the Manawatu-Wanganui region, and downhole temperatures were found for four of these wells (Table 8). The temperatures (41 to 73°C) are sufficiently high for some applications, particularly since one of these wells (Parikino-1) is close to a school, marae, and several houses. Temperatures generally increase with depth, so even higher temperatures are likely at greater depth.

■ **Table 7 Warm springs in the Manawatu-Wanganui Region (from Mongillo & Clelland 1984)**

System		Flow l/s	Max. T °C	Notes
1	Jerusalem			"Warm springs"
2	Pipiriki	5	23	
3	Ruapehu crater		50	Acid, on an active volcano, and within a national park

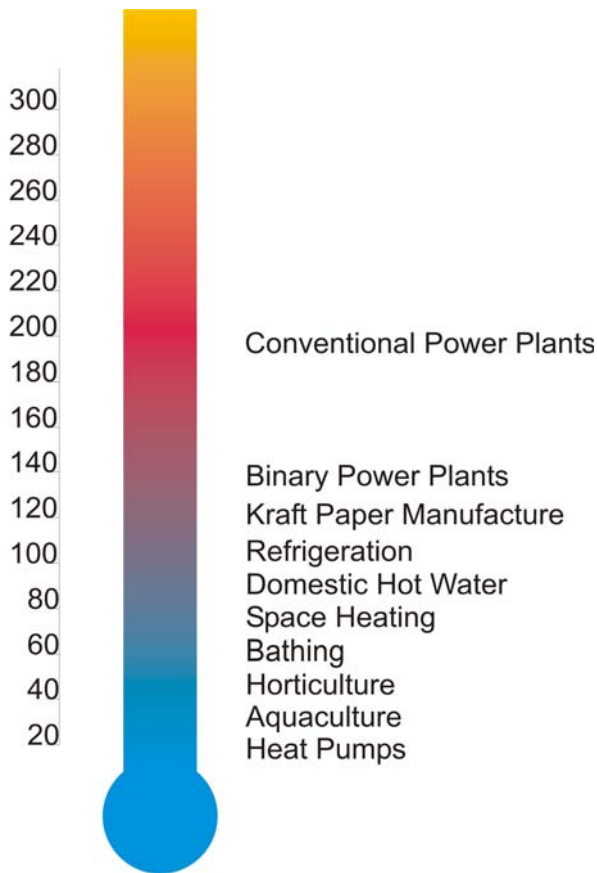

■ **Figure 15 Temperatures (°C) required for some direct use geothermal applications**

■ **Table 8 Temperatures in some onshore Manawatu-Wanganui oil and gas wells (from MED 2006)**

Well name		Depth	Max. T °C	Well status
1	Parikino-1	2316	41	Plugged and abandoned
2	Puniwhakau-1	2146	46	Plugged and abandoned
3	Waikaka-1	978	44	Plugged and abandoned
4	Whangaehu-1	3495	73	Plugged and abandoned

All of the onshore wells have been plugged and abandoned, although they could be reopened if it was worth it to extract the heat from them. However, it is important to recognise that in addition to heat, it is necessary to have fluid (water) present to bring that heat to the surface. Unless the fluid



within the well is overpressured, it will need to be pumped to reach the surface, in which case the benefits may be outweighed by the cost of pumping, depending on the fluid temperature.

**Horticulture** (greenhouse) geothermal heating systems have been developed in many countries, including at Mokai and Kawerau geothermal fields in New Zealand.

**Aquaculture** projects include the Wairakei prawn farm, which uses waste hot water from the Wairakei power plant.

A range of **industrial applications** can make use of geothermal fluids over a wide temperature range. These include timber drying, pulp and paper manufacture, dairy processing, and many other applications.

Geothermal **space heating** is common where high temperatures are present at shallow depths (*e.g.* in parts of Taupo), though ground source heat pumps may be more practical in Manawatu-Wanganui.

Elsewhere in the world, **ground source heat pumps** (GSHP's) have become widely used since the 1980s. Heat pumps permit the extraction of heat from the ground or from groundwater, in a similar way to standard air conditioning, only instead of using ambient air for the heat source (or sink), ground or groundwater is used (Figure 16). Ground source heat pumps are much more efficient than standard air conditioning units because in winter, when heating is required, the ground is warmer than the air (even away from thermal areas), and in summer, when cooling is required, the ground is often cooler. The only energy required is that needed to pump the circulating fluid through the system. This technology is used on a large scale in North America and Europe where the climate, high electricity prices and subsidies make this technology economic. These drivers are largely absent in New Zealand and as a result there has been little uptake of the technology here.

All other factors being equal, GSHP's are most cost effective in areas with climatic extremes (cold winters and hot summers) because the pump provides both heating and cooling and is used for longer periods and at high rates. As a result, the capital investment can be recovered in a relatively short time.

Thain *et al.* (2006) provide estimates of annual costs for space heating and assisted water heating using GSHP in New Zealand. For a typical household with an electricity price of 12c/kWh, and space heating for 800 hours per year, the annual heating cost (space and water) is \$520 compared to \$1320 for electricity alone, i.e: a saving of \$800 per year (~60%). However, this is not a sufficiently high saving to compensate for the initial high capital cost (about \$12,000). On this basis, it is unlikely that GSHP's will find favour for domestic heating in the Wanganui area, particularly if natural gas is available.

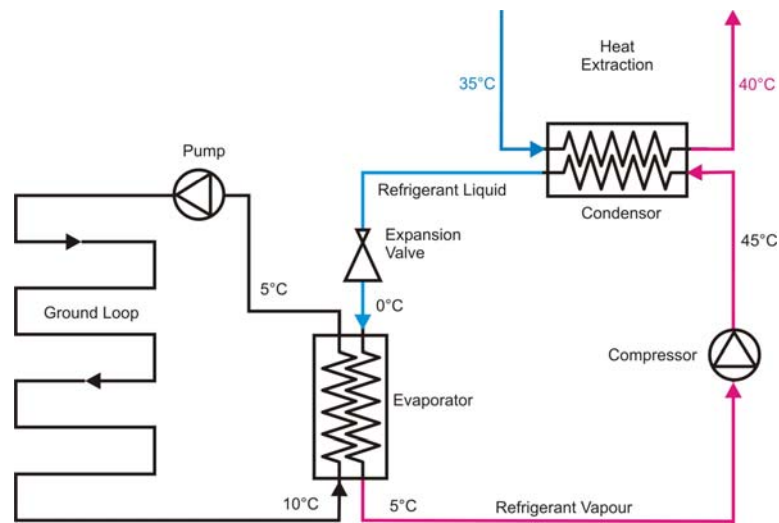
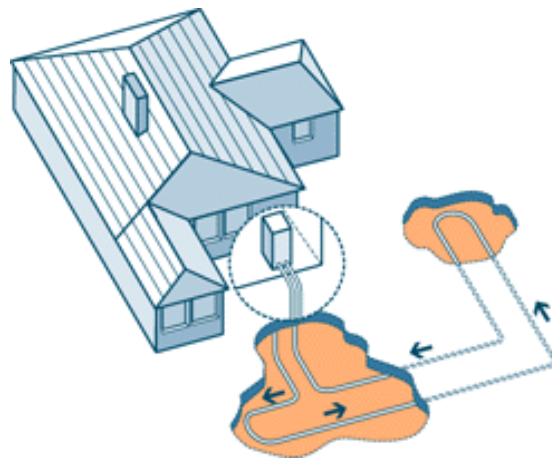

■ **Figure 16 Schematics of a ground source heat pump system.**

For larger commercial buildings which often require heating and air-conditioning, economies of scale may make GSHP's economic, particularly where there is a source of water to improve efficiencies (e.g.: river-side developments).



By far the most widespread use of low temperature geothermal resources in New Zealand is for **bathing**. Hot baths and spa complexes have been developed at many of the high and low temperature systems throughout the country, but not in the Manawatu-Wanganui Region.

#### 4.6.3 Summary of Resource Potential

*Temperatures in some abandoned oil and gas exploration wells are possibly sufficient for some direct use applications, provided adequate flows could be obtained.* Ground source heat pumps constitute a largely untapped resource, and can be used throughout the entire region, not just in areas of warm ground.

## 4.7 Marine

### 4.7.1 Tidal Resource

Tides are the periodic rise and fall of large bodies of water caused by the gravitational interaction between the astronomic bodies within our solar system. This may be simplistically understood as the gravitational attraction of the moon causing the oceans to bulge. Another bulge occurs on the opposite side, since the Earth is also being pulled toward the moon (and away from the water on the far side). Since the earth is rotating while this is happening, two tides cycles occur each day. At periodic 28 day intervals the alignment of the moon, sun and earth causes an additive effect creating stronger tides and conversely at other times weaker tides. Although the influence of these effects is generally diffuse, localised bathymetry concentrates tidal flows in certain regions into areas of highly energetic activity.

A number of factors come into play when estimating and assessing the extent of the resource and its 'harvestability'. These can be grouped into two categories: 'site' and 'technology'. Site assumptions are focussed around the extent of the resource itself while the technology group is focussed around the technical issues of harnessing the resource. A critical decision in determining the extent of the resource is based around estimating the flow velocity and its variability dependant upon the lunar cycle. As a complete set of detailed data for every site of potential interest is seldom available, certain assumptions or extrapolations must be made.

Typically these will concentrate upon:

- Influence of the boundary layers on flow rates (both seabed and channel sides) and the effect they have on flow through the channel cross section between 'mean peak spring velocities' and 'neap' flows (Figure 17)
- Variance of flow within tidal 'ebb' and 'flood'
- Presence of bathymetry oddities that cause 'hot' and 'cold' spots



- Thresholds of energy extraction beyond which tidal flow pattern will change in response to the extraction itself (*i.e.* channel blockage effects)

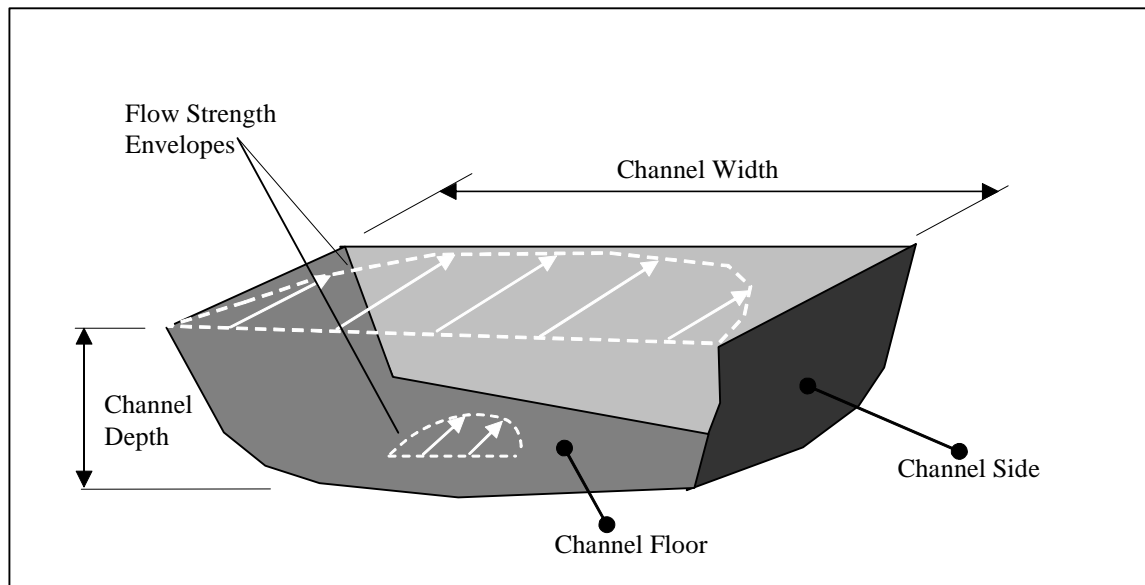

■ **Figure 17 Cross sectional view of tidal channel**

Factors influencing ‘harvestability’ are largely technology dependant:

- Efficiency of devices to capture energy and convert it to electrical power (Figure 18). As devices operate in flow environments that are far from constant, design compromises result in the device being designed to only operate across a selected range of conditions. Typically the device will have a ‘start up’ flow velocity, below which it does not operate, and a ‘rated power’ beyond which it does not operate. Below the cut in and above the rated power, the device will ‘shed’ power.
- Reliability of the device and the speed with which repairs can be executed
- The density of device deployment or spacing within an array
- The location of the device relative to boundary layers
- The transmission efficiency of the electrical connection relative both to land and the end user proximity
- Needs of other maritime users



The tidal range in New Zealand is low (2 to 3 m) compared to many other places around the world (up to 10 m in the UK). Nevertheless there are some sites around New Zealand with significant tidal currents. Most promising are the areas around headlands, together with Cook and Foveaux Straits and the entrances of some natural harbours. Maritime tidal atlases suggest that the maximum tidal current in those harbour entrances is approximately 2-3 m/s.

The information available regarding tidal flow patterns in the region is limited and indicates that the tidal flows seen within this region are insufficient for power generation.

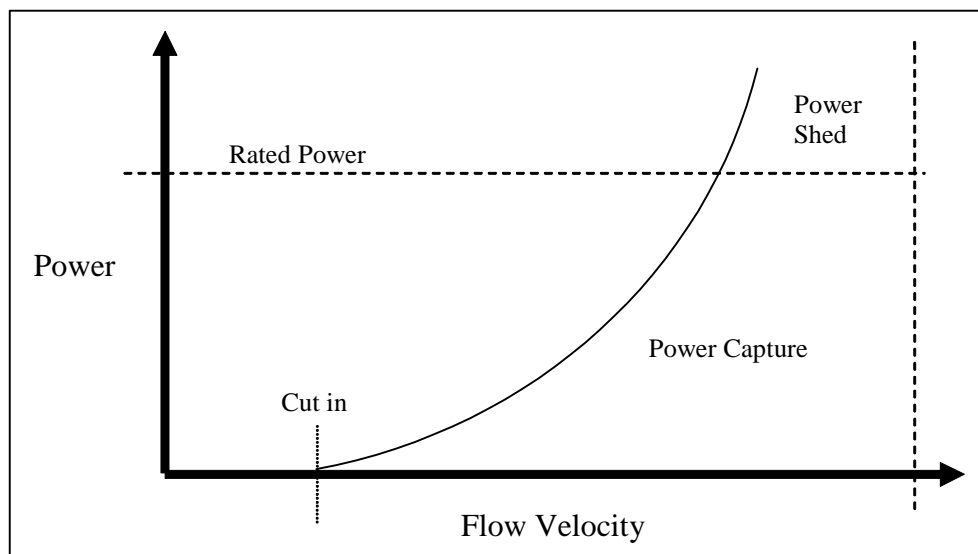

■ **Figure 18 Generic device power capture graph**

### Generation capacity

The two key geographical factors determine the suitability of a site for the deployment of tidal stream extraction technologies are flow rates and water depths;

- 1) Flow rate is highly significant as the power is proportional to the cube of the flow velocity. This may be illustrated by understanding that the power increases by a factor of 8 every time the flow doubles. Therefore tidal developments in the short to medium term are only likely to be economically viable in sites of higher flow. Discussion with existing technology developers suggests that sites where spring peak flows exceed 5 knots are required. In the context of the areas covered within this study this is greater than the available resources.
- 2) As water channels are generally much greater in width than depth, water depth acts as the constraining factor in available energy capture. This factor is compounded by the seeming



convergence in the development of horizontal axis twin bladed turbine type technologies, whose power capture is determined by a swept circular cross section. Full sized machines have a blade diameter of typically 20m and are situated in 30-40m of water if mounted on a mono-pile foundation, with options for greater than 40m if based upon floating - sea bottom tethered configurations. In the context of the areas covered within this study the technology presently being developed is not suitable for deployment in the relatively shallow waters found within harbour regions.

To summarise, the sites considered within this study are not well suited to tidal technology developments both in terms of insufficient tidal flow velocities meaning that these sites are not well suited to short to medium term exploitation.

#### **4.7.2 Wave Resource**

Ocean waves are created by the conversion of kinetic wind energy acting across the surface of an area of open water, where the energy within the wind acts upon the surface friction of the water such that with time it creates an orbital water particle motion. The open space expanse over which the wind and water have opportunity to interact is referred to as the fetch. The interaction between the wind and sea is such that the energy transfer between the mediums will continue until such a point that either equilibrium is reached (this is known as a fully developed sea) or that the fetch length is such that the waves enter shallow waters and break. Wave energy additionally has a directionality component related to the wind direction driving the fetch.

As wave energy propagates nearer to coastal regions, it experiences several physical changes whose additive effect is to reduce the levels of energy resource found in shallow coastal waters as compared to their deep water ocean counterparts. The driving factor in this transformation is water depth. As deep water waves enter coastal waters (deep water is where the water depth is greater than half the wave length), a transition in the wave characteristics occurs. Whilst the wave frequency remains the same, three factors change:

- The wave length shortens
- The wave amplitude increases
- The wave velocity reduces

The above changes are underpinned by the fundamental mode change of the wave's water particle velocity path from circular to elliptical. This is caused by the influence of the seabed and its friction acting upon the wave propagation. At a point where the wave has grown in height by around 1.3 times, its steepness will be such that it topples over and can be visually seen as surf.

As with the tidal case study, the estimates of both the total and attainable wave resource are based upon a set of assumptions that significantly impact the overall results. These assumptions are summarised:



- Distance to land mass for grid connection
- Single device capture efficiency
- Device availability
- Device spacing within array
- Transmission efficiency
- Minimum allowable site area
- Site survey data
- Needs and rights of other maritime users

Many of the above are directly analogous with the tidal situation. However wave device power capture efficiency is somewhat different. Unlike tidal, where the dominant variable in the power calculation is velocity, with waves, power capture is a combination of wave period and height (Figure 19), thus creating a 3-D scenario. Typically a device will be designed such that below a certain threshold or ‘cut in’ the device will shed power. Above a certain threshold associated with its rated power, the device will also shed power, and in high energetic storm conditions the device may shed power as a survivability strategy.

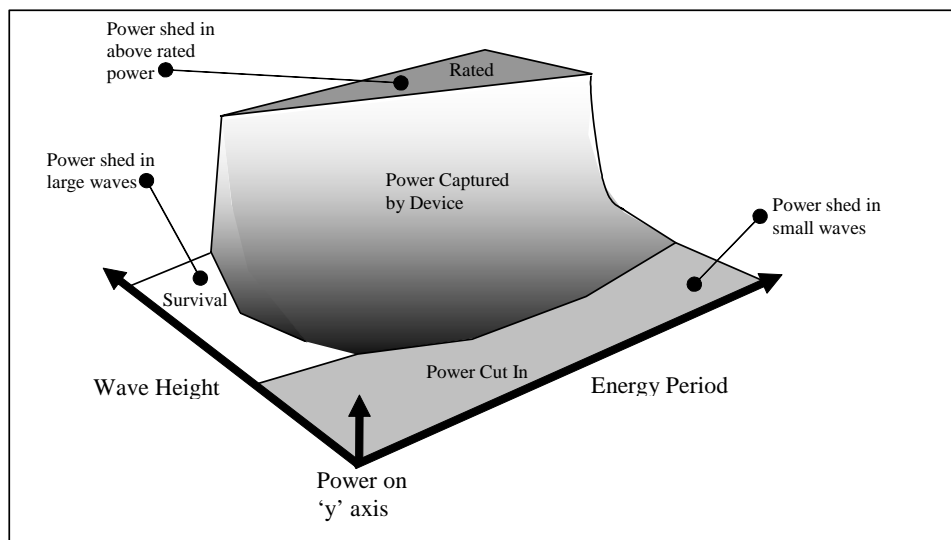

■ **Figure 19 Typical wave device power capture**

In New Zealand, the weather systems that are driven up from the southern ocean play a major influencing role. It follows that offshore and coastal regions exposed to these influences will contain a greater abundance of wave energy than more sheltered areas. Accordingly, reports show that the annual average wave power around the New Zealand coast varies from 8 kW/m at East Cape to 99 kW/m near Stewart Island. A typical value is around 30 kW/m, which is favourable in



terms of global energy potential. Figure 20 shows average significant wave height for coastal areas of New Zealand for the period 1979-93. The presentation is given in terms of ‘Significant Wave Height’ (a simple statistical tool of averaging the height of the highest one third of the waves in a given sea state). As a guide, areas with greater significant wave height have better potential for wave power electricity generation.

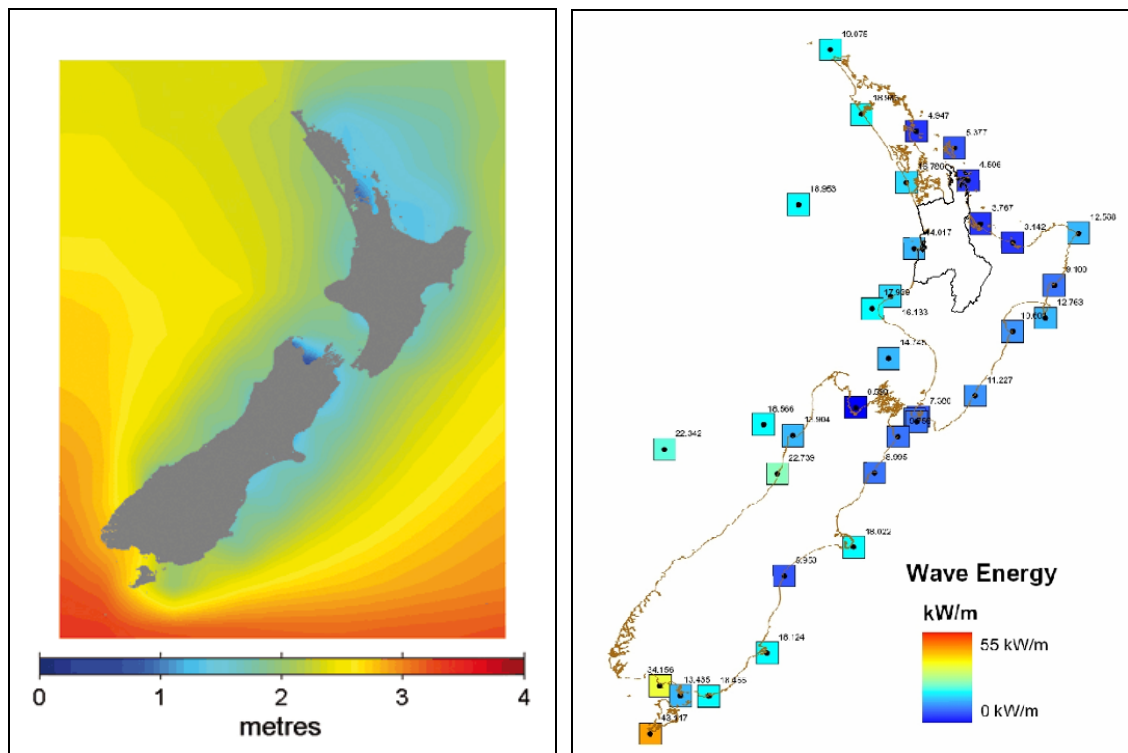

■ **Figure 20 Mean wave height from 1979 to 1998 and wave energy (NIWA 2006d, East Harbour Management Services 2005)**

Another study provides an annualised average wave energy atlas for selected locations around the New Zealand coastline and offshore deep waters (Figure 20). This information is provided in kW/m. Relative to this region, data is provided 98 km due west of the region. This information states that resource potential power levels of 14.7KW/m.

To illustrate the attainable power potential a simple case study based upon resource potential and assuming Pelamis (<http://www.oceanpd.com/>) deployed technology may be considered to demonstrate the wave power extraction viability. Operating in the 15.7 KW/m wave climate environment each unit would produce around 150 KW (Significant wave height 2.0m and wave period of 8 seconds) and spacing the units 150 m apart a farm array of 14 devices would occupy a



foot print of 2100 m by 150 m. Assuming the developers quoted load factor of 40%, the annual energy production per unit would be 526 MWhr which approximates to 7.36 GWhrs per farm.

Several practical issues must be borne in mind. A wave farm further from a shoreline connection point will have a more significant subsea electrical cabling connection cost burden than one nearer. This can be overcome by locating the farm nearer to the shore but a trade off exists as energy resource availability will decrease in shallower water depths (<50 m) (Figure 21). Additionally dependent on the strength of the local shoreline electrical transmission systems upgrade measures may be necessary, which also have an associated cost burden.

*Based on these numbers it is estimated that about 7 MW/km<sup>2</sup> of wave energy devices could be installed. With a coastline length of around 100 km, this equates to a capacity potential from wave energy in the several hundreds megawatt range, ignoring environmental constraints and conflicts with other maritime users.*

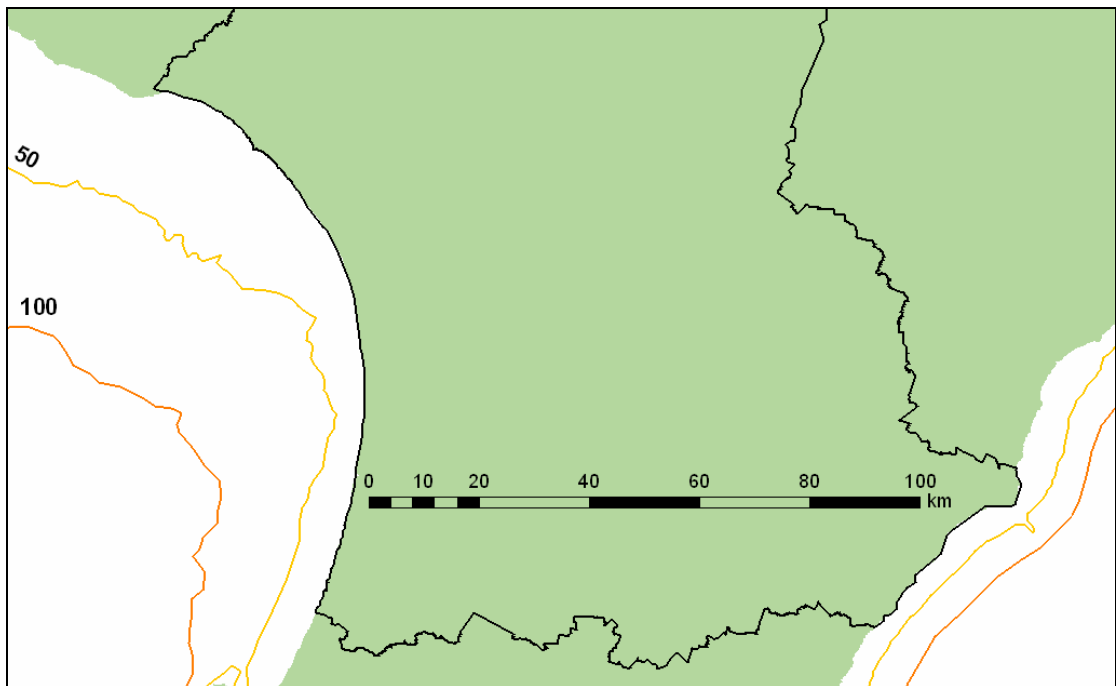

■ **Figure 21 Water depth contours along the Manawatu-Wanganui coastline (depths in metres)**



## 5. Enabling Assistance

### 5.1 Introduction

Although the focus of the current study has been to assess renewable energy resources and regulatory approaches at the regional level, there are a variety of non-regulatory methods (referred to here as ‘enabling assistance’) which could also be developed to encourage greater renewables uptake. This chapter presents a number of such approaches for consideration by councils, particularly for those regions where there is a clear and pressing energy issue such as those outlined in Section 2.6.

### 5.2 Renewable Energy Expertise

Renewable energy can be viewed as a development activity with potentially adverse local environmental impacts but with national energy benefits (*e.g.* security of supply) and international environmental benefits (*e.g.* climate change). As such, the inclusion of renewable energy in the Resource Management Act (RMA) needs to be recognised as a departure from the norm for councils who have primarily been responsible for managing regional environmental resources. At the same time, the inclusion of renewable energy in the RMA is consistent with the councils’ role in the meeting of national and international objectives on issues such as biodiversity.

As such, with a number of notable exceptions, the majority of councils have limited in-house expertise on issues relating to energy and renewable energy. This is perhaps unsurprising given councils’ core functions under the RMA, the relatively recent inclusion of renewable energy in the RMA and the rapid development in renewable energy technologies. However, it is clear that if the councils are to play a role in the greater uptake of renewables through either regulatory or non-regulatory approaches, then additional expertise is required. This should be such that a council’s capacity with regard to renewable energy is commensurate with that of its other functions, *e.g.* soil conservation or water quality. This would assist the high-level resolution of how proposed renewable energy developments might affect aspects of the regional environment.

Whilst the requirements for renewable energy expertise will vary between councils, it will largely be determined by the region’s and council’s aspirations and the renewable resources available in the region.

### 5.3 Renewable Energy Plans / Strategies

The urgency and type of energy issues varies substantially between regions. For those regions with one or more pressing energy issues, such as those outlined in Section 2.6, councils may wish to consider the development of an energy plan / strategy. This would typically be positioned as an economic development or infrastructure plan / strategy rather than an implementation mechanism under the RMA. Such an approach would provide for design flexibility, speed of implementation



and the ability to consider wider, non-renewable energy issues. A preliminary indication of this regional approach is provided by the Southland Regional Energy Strategy (2004).

#### **5.4 Resource / Constraint Mapping**

The issue of developing spatial representations of renewable energy resources overlaid with information relating to development constraints (*e.g.* outstanding landscapes, areas of high cultural value) was raised at a number of discussions with councils. Whilst Section 4 provides an indication of the magnitude and location of renewable energy resources in the region, more detailed information would be required to prepare resource maps of value to regional policy statements and plans. This type of more detailed information is likely to be held by a disparate group of organisations including renewable energy developers, research organisations and regional / district councils. For instance, with regard to wind resources, extensive field studies have been undertaken by developers and historic records are held by meteorological departments. The most detailed and reliable information is commercially sensitive and as such, is unlikely to be made available to councils. However, broad-scale resource maps could be developed in a cost effective manner by combining information held by public institutions with commercially available numeric models or numeric modelling capabilities.

It is to be noted that mapping also presents a potential new constraint to greater renewables uptake in that broad scale resource mapping may overlook small high potential areas. Furthermore, constraint mapping without adequate consultation with the renewable energy sector may inadvertently screen out areas of medium or high potential. As such, decisions on whether and how to develop resource / constraint maps requires careful consideration. Developers also express concern that once detailed resource maps are available, landowners can demand much higher access or “mitigation” fees, presenting a secondary barrier to renewables. Section 6.2.1 provides a further discussion on the identification of suitable sites for renewable energy developments.

#### **5.5 National Renewable Energy Forums**

In order to promote good practice on both regulatory methods and enabling assistance and develop a deeper appreciation of the issues associated with renewable energy, a programme of forums involving selected councils from across New Zealand could be established. Alternatively, renewable energy could be brought into existing forums, such as those for the Chief Executives of councils.

#### **5.6 Economic Instruments**

RMA financial contributions are to be taken, and used, for a purpose specified in the relevant plan. These could be used to charge a greater contribution to energy generation methods that create the greatest environmental damage. For example non-renewable generation that creates air discharges could be charged on the basis of the volume of type of discharges produced.



The rules providing for such contributions would have to be written into a Plan and would be a requirement on resource consents. There are a number of issues with such financial contributions.

Firstly the process of placing the required rules into a District Plan is complex and may take a considerable effort and time. The environmental effects that the financial contribution relates to will need to be fully justified and defined accurately in terms that can be translated into monetary terms.

There is also a case that can be argued that the environmental effects of emissions are national in nature and reducing such emissions creates national benefits. It may therefore be that any economic instruments are better justified at a national level rather than at the local level.

Other economic instruments such as carbon taxes, tax incentives for renewable energy projects and variable electricity pricing (giving advantages to renewable energy) are not available to councils and will rely on Central Government implementation. Councils may have an advocacy role in respect of these matters.



## 6. Regulatory Approaches

### 6.1 Current Regulatory Approaches

The main regional policy and regulatory document in the Manawatu – Wanganui Region is the Regional Policy Statement. The Regional Policy Statement was made operative in July 1998. The Regional Policy Statement is currently under review.

The RPS contains a comprehensive section on energy with the objectives and policies being;

#### *29.3 Objective 28*

*To promote the sustainable management of energy resources.*

#### *Policy 28.1*

*To promote the sustainable supply and use of energy resources to meet the needs of the regional community.*

#### *Policy 28.2*

*To promote the increased use and development of renewable energy sources where practicable.*

#### *Policy 28.3*

*To promote efficiency in the use of energy and the implementation of energy efficiency procedures.*

#### *29.4 Objective 29*

*To avoid, remedy or mitigate the adverse effects of energy generation in the Region.*

#### *Policy 29.1*

*To ensure that proposals for developments of energy generation undertake full Environment Impact Assessments in accordance with the requirements of Section 88(6)(a) and the Fourth Schedule of the Act prior to consideration by the relevant authorities.*

The Regional Policy Statement lists a number of implementation methods and seeks to balance promotion of renewable energy with managing adverse effects. This section of the Regional Policy Statement also identifies a number of other objectives that may impact on energy generation. These relate mainly to the protection of resources. The Regional Policy Statement does not appear to consider the 2004 amendments to the Act which is assumed to be largely due to the age of the document.



The Council is proposing to review the Regional Policy Statement and incorporate it within a single Resource Management Plan or “One Plan” for the Region. The Council has made available draft versions of the new “One Plan” that will concentrate on a smaller range of more achievable outcomes than the current document. At this stage indications are that the energy section will be reduced, but will concentrate more on renewable energy. At this stage these provisions are not fully developed.

The Horizons Regional Council has the following regional plans;

- Regional Air Plan – Operative January 1998
- Regional Plan for the Beds of Rivers and Lakes and Associated Activities – Operative March 2001.
- Regional Coastal Plan - Operative 1997 with updates operative 2002.
- Oroua Catchment Water Allocation Plan – Operative 1997
- Manawatu Catchment Water Quality Plan – Operative October 1998
- Land and Water Regional Plan – Operative September 2003

While a number of these plans directly affect renewable energy, for example controlling use of rivers for dams, they do not explicitly promote renewable energy and in some instances will prevent it.

There are 7 Territorial Local Authorities within the Manawatu - Wanganui Region. The current regulatory approaches of the Councils are summarised below.

### **Horowhenua District Council**

The Horowhenua District Plan became operative in 1999. The Plan appears to have no specific policies relating to renewable energy.

### **Manawatu District Council**

The Manawatu District Plan became operative in 2002. This District Plan contains a section on energy and water use and air quality. This contains the following objective and a number of associated policies.

*EWA 1) To promote sustainability of energy and water use through more efficient use, conservation and a higher degree of local self sufficiency, as well as a move toward renewable energy sources.*



The regulatory methods used in the District Plan include providing for solar access to buildings.

### **Palmerston North City Council**

The Palmerston North City District Plan became operative in 2004. The District Plan contains a specific section relating to utilities but does not specifically provide for renewable energy.

### **Rangitikei District Council**

The Rangitikei District Plan became operative in 1999. The District Plan contains a specific section relating to utilities but does not specifically provide for renewable energy.

### **Ruapehu District Council**

The Ruapehu District Plan became operative in 2000. The District Plan provides for existing hydroelectricity generation facilities as a special activity. Otherwise the District Plan does not make specific provision for renewable energy.

### **Tararua District**

The Tararua District Plan was made operative in 1998. The District Plan contains a section relating to utilities. Energy conservation and provision for renewable energy is provided for in terms of energy conservation in buildings and subdivisions.

### **Wanganui District**

The Wanganui District Plan was made operative in 2004. The Plan appears to have no specific policies relating to renewable energy.

## **6.2 Potential Regulatory Approaches**

The following policy suggestions examine some ideas concerning how the Horizons Council may be able to provide for renewable energy use and generation through its Regional Policy Statement and Regional Plans.

### **6.2.1 Identification of Suitable Renewable Energy Locations**

Regional Policy Statements and Plans can assist the provision of renewable energy by identifying the potential locations where forms of renewable energy generation that have specific locational constraints may be appropriately located. Resources that have potential locations that can be identified typically include wind-power sites, hydro, geothermal and marine based energy sources. These locations can be illustrated on maps within the Policy Statement or Regional Plan.

The development of this mapping should include the identification of any potential environmental effects that may limit or preclude the use of the resource in terms of sustainable management of natural and physical resources. For example, some areas suitable for wind generation may also be



in areas of outstanding landscape value. Some rivers that may be able to be used for hydro electricity generation may have high environmental values that would preclude such development.

An alternative to mapping areas with particular energy potential (where this is not possible or desirable) is to identify broader natural area classifications where particular types of energy development is appropriate and provide for more permissive rules for development within those areas.

Following the 2005 amendments to the RMA, Regional Policy Statements can where appropriate direct District Plans to make suitable provision for the development of renewable energy in locations identified in such mapping. Alternatively the mapping can be used to give policy direction to resource consent processing at both regional and district levels. The maps can also be used to develop appropriate rule packages in the council's own Regional Plans concerning the use and taking of water and the coast etc.

While such locational based policy development has not to date been used extensively in Regional Policy Statements and Plans the approach is valid and is starting to be used more frequently. For example the Auckland Regional Policy Statement details the Metropolitan Urban Limits on a map. A mapping approach is also enabled via the 2004 amendment to the Resource Management Act that enabled the establishment of aquaculture management areas. A similar approach is also taken in the geothermal chapter of the Environment Waikato Policy Statement.

### **Recommendations**

- (i) That where possible the Regional Policy Statement identify areas within the region suitable for renewable energy development including wind, hydro, geothermal and marine based generation. The location of these areas should be developed taking into account the potential effects of such generation facilities and the sustainable management of natural and physical resources.
- (ii) That District Plans should be amended to ensure that rules do not preclude renewable energy development in areas identified in the Regional Policy Statement. (For example landscape protection areas should not identify areas deemed suitable for wind power generation in the Regional Policy Statement.)
- (iii) That Regional Plans and District Plans provide for existing renewable energy generation facilities. For example specific zones may be provided for existing hydro stations.



### **6.2.2 Non-Locational Policy Development**

Some renewable resources are not locationally constrained or there may be insufficient information about a resource and its effects available to develop a locational approach (e.g. biomass generation).

Regional Policy Statements and Plans can assist the provision of renewable energy by developing detailed policy on how “trade offs” between various resources can be made. It is considered that this approach is mandated by the changes to the Resource Management Act that requires Councils to have particular regard to the benefits to be derived from the use and development of renewable energy. This approach essentially considers the benefits of renewable energy and looks at various “trade offs” between the local and wider benefits of that development and the localised environmental effects that may result from renewable energy generation and transmission within the context of sustainable management of natural and physical resources. If direction on such decision making is not specified by the council, then it is difficult for councils to balance the benefits of renewable energy against other environmental effects when considering consent applications. It is considered that these policies need to be as detailed as possible so as to give firm direction.

Examples of this approach may include;

- Developing policy to the effect that in some areas of outstanding landscape value wind farms will be allowed because of the nature of the wind resource in that area. I.e. trading off landscape values against renewable energy resources. The policies recommended could say that where the wind resource is greater than a particular level then it may take preference over landscape values. Another approach may be to have policies that allow wind farms in all but the most outstanding landscapes.
- Developing policy to the effect that where rivers have already been compromised then further hydro development may be appropriate or deciding that hydro is appropriate on all rivers except those with conservation orders on them.
- Developing policy to the effect that tidal power development is appropriate in the Coastal marine area except where such development will effect endangered species of marine fauna and flora. This is trading off the natural character of the coast except where the most valued natural resources are located. A similar approach is taken with marine farm sites in some areas which are based on not effecting special marine resources such as some areas of threatened sea weed that are necessary for fish reproduction and feeding.

### **Recommendations**



- (i) That the Regional Policy Statement include a series of objectives and policies outlining how “trade offs” between localised effects and the benefits of renewable energy should be made.
- (ii) That District Plans be amended to give effect to the Objectives and Policies developed in (i) above.

### **6.2.3 Consents**

Discussions with industry players have indicated that consenting issues are a significant disincentive to the development of some forms of renewable energy. There are a number of consenting options that councils can investigate that would provide encouragement for the development of renewable energy.

Ways in which consenting can be modified include the use of incentives within the consenting processes to encourage the use of renewable energy. Incentives could include:

- greater air discharge thresholds for biomass energy generation (where this can be supported by appropriate ambient air quality), or
- reduced consent thresholds (types) when based on renewable resources, or
- longer consent periods before consent renewal for use of renewable resources than for non-renewable resources.

Codes of practice for renewable generation can be used within consenting processes. Such an approach requires the development of codes of practice, and compliance with these will be accepted instead of the need to comply with rules, or alternatively result in simpler forms of resource consent where compliance with the code of practice is achieved. This technique is reasonably common in Resource Management Act plans with some other issues. Regional Energy Strategies and Regional Energy Forums may be suitable avenues for developing codes of practice around a number of renewable energy resources. These will likely need development in association with generators, District Councils and other interested parties.

### **Recommendations**

- (i) That Regional Plan rules be amended to provide greater air discharge thresholds for biomass energy generation where this can be supported by ambient air quality.
- (ii) That Regional Plan rules be amended to reduce consent thresholds for energy generation based on renewable resources.
- (iii) That Regional Plan rules be amended to provide longer consent periods for renewable energy projects.



- (iv) That the council work with energy generators, District Councils, Tangata Whenua and other interested bodies to develop industry codes of practice for renewable energy production.

#### **6.2.4 Domestic or Small Scale Developments**

The scale of potential renewable energy projects may also be considered by Councils in setting policy, consents thresholds and notification requirements within plans. In some cases it may be just as difficult to obtain consent for a small scale project that has a low level of local environmental effects as for a large renewable energy project, as plans do not always make distinctions between small and large scale effects. This tends to encourage large scale projects that may have more significant effects than a series of smaller scale projects.

For example, small scale hydro generation projects that do not use dams or do not divert significant volumes of water could be rendered subject to lower consent thresholds than large projects. For example, a wind farm with only one or two turbines will have less visual effects than a large wind farm, yet often a similar consent process is required for both. This situation could be changed by setting scale thresholds for resource consents whereby smaller scale projects are made subject to controlled or restricted discretionary activity consents whereas larger scale projects require fully discretionary resource consents. Domestic scale generation may be able to be a permitted activity.

At the District level for example, Franklin District Council makes specific provision for some small scale renewable energy generation as permitted activities in rural areas.

#### **Recommendations**

- (i) That the Regional Policy Statement, Regional Plans and subsequently District Plans be amended to make appropriate provision for various scale energy generation facilities.
- (ii) That the Regional Policy Statement, Regional Plans and subsequently District Plans be amended to allow small scale renewable energy production (including solar and wind) as permitted activities.
- (iii) That District Plan subdivision rules provide site orientation provisions in order to support solar heating and power generation.
- (iv) That District Plans rules should be amended to ensure that development control rules (*e.g.* maximum height rules) do not unreasonably preclude domestic scale renewable energy production (*e.g.* allows solar panels on roofs) and protect solar access to nearby properties.



### **6.2.5 District Plans**

Section 75(3) of the Resource Management Act requires District Plans to give effect to a Regional Policy Statement. Councils are therefore able to give direction to the types of rules and policies that the constituent District Councils are able to place in District Plans that directly control land use.

Good practice would dictate that this power should be used in conjunction with a collaborative approach to issues with District Council. Councils are well positioned to influence how District Plans in their region provide for renewable energy generation through specific policy direction within Regional Policy Statements. The nature of the energy resources within the region are such that each District has its own unique range of resources. The response of each District is likely to be different based on the nature of resources in each District.

#### **Recommendation**

- (i) That the council work closely with the District Councils within the region to ensure that District Plans reflect the renewable energy objectives and policies of the Regional Policy Statement.

### **6.2.6 Future Proofing Policy Statements and Plans**

In developing the next generation of Regional Policy Statements and Plans, Councils should have regard to the potential developments in renewable energy that may occur in the region over the life of the Policy Statement or Plan.

For example, many regions have large areas of coastline that may be suitable for one or more forms of marine electricity generation through the life of a Regional Policy Statement or Regional Coastal Plan. Because this technology is still evolving, polices (and rules in Regional Coastal Plans) could consider how new technologies may be used in the future, what potential environmental effects may result and the circumstances in which such technology may be put in place. In effect polices may be developed in a way that future proofs the policy statement/plan by making provision for new technology to the extent possible under current levels of knowledge.

#### **Recommendations**

- (i) That the Regional Policy Statement and Regional Plans be amended to recognise potential future renewable energy technologies and make high level policy provision for such technologies.
- (ii) That the council monitor the state of technology development and make changes to the Regional Policy Statement and Regional Plans to make appropriate provision for developing technologies.



## 7. References

BRANZ, 2004: Study Report No. SR 133. Energy Use in New Zealand Households – Report on the Year 8 Analysis for the Household Energy End-use Project (HEEP).

Canterprise, 2005: <http://www.windenergy.org.nz/images/050902-Canterprise-WindMap99kb.gif>

CAE 1992: Our waste our responsibility: towards sustainable waste management in New Zealand: project report. University of Canterbury Centre for Advanced Engineering.

Deffeyes, K. S. 2001: Hubbert's Peak: The Impending World Oil Shortage. Princeton University Press, Oxfordshire.

East Harbour Management Services, 2004: Waters of national importance – identification of potential hydroelectric resources. Report prepared for Ministry of Economic Development.

East Harbour Management Services, 2005: Renewable energy industry status report 2<sup>nd</sup> Edition. Report prepared for EECA. Includes data from NIWA (Frazerhurst).

East Harbour Management Services, 2005: Availabilities and costs of renewable sources of energy for generating electricity and heat. Report prepared for Ministry of Economic Development.

EECA, 2001a: Review of New Zealand's Wind Energy Potential to 2015, EECA, 2001

EECA, 2001b: Solar Energy Use and Potential in New Zealand, EECA, 2001

EECA, 2004: EECA Energy End Use Database (<http://www.eeca.co.nz/enduse/index.aspx>)

EECA & CAE, 1996: New and Emerging Renewable Energy Opportunities in New Zealand.

Enconsult 1981: A comparative assessment of the production of transport fuels in New Zealand from coal and biomass. Report produced for the Liquid Fuels Trust Board by En-Consult Technology Limited, June 1981.

Hay, P.S. & Hancock, L.M. 1904: The Hay report.

Jackson, S., 2001: Hot springs of New Zealand. Reed Publishing, Auckland.

Lund, J., Sanner, B., Rybach, L., Curtis, R., and Hellstrom, G. 2003: Geothermal (ground-source) heat pumps: a world overview. Geo-Heat Centre Quarterly Bulletin 25 No 3: 1-10.

MAF, 2005: Ministry of Agriculture and Forestry website, Production statistics 2005: <http://www.maf.govt.nz/statistics/primaryindustries/forestry/index.htm>



Ministry of Economic Development (MED), 2003: Energy Outlook to 2025.

Ministry of Economic Development (MED), 2006: Energy Data File January 2006

Ministry of Economic Development (MED), 2006: New Zealand petroleum well reports.  
[http://www.crownminerals.govt.nz/petroleum/data/Petroleum\\_Wells\\_Search.asp?](http://www.crownminerals.govt.nz/petroleum/data/Petroleum_Wells_Search.asp?)

Mongillo, M.A., Clelland, L., 1984: Concise listing of information on the thermal areas and thermal springs of New Zealand. DSIR Geothermal Report No. 9.

NIWA, 2006a: The National Climate Database

NIWA, 2006b: [http://www.niwascience.co.nz/pubs/wa/13-4/images/renewable3\\_large.gif/view](http://www.niwascience.co.nz/pubs/wa/13-4/images/renewable3_large.gif/view)

NIWA, 2006c: [http://www.niwascience.co.nz/pubs/wa/13-4/images/renewable4\\_large.gif/view](http://www.niwascience.co.nz/pubs/wa/13-4/images/renewable4_large.gif/view)

NIWA, 2006d: [http://www.niwascience.co.nz/pubs/wa/13-4/images/ocean2\\_large.gif/view](http://www.niwascience.co.nz/pubs/wa/13-4/images/ocean2_large.gif/view)

OECD, 2006 Factbook 2006: Economic, Environmental and Social Statistics

Palmerston North City Council, 2006: Turitea Reserve Consultation Document:  
[www.pncc.govt.nz/Council/Consultation/ConsultingOn.htm?Channel=Consulting&ChildGuid={6608EF8A-5C94-4797-AE30-390A4B6CBAC6}](http://www.pncc.govt.nz/Council/Consultation/ConsultingOn.htm?Channel=Consulting&ChildGuid={6608EF8A-5C94-4797-AE30-390A4B6CBAC6})

Parsons Brinkerhoff Associates, 2005: Hydro-electric potential in New Zealand – a hydro-electric resource database. Report prepared for Electricity Commission.

Rybach L. (1997) Market Penetration of BHE Coupled heat pumps. The Swiss Success Story. Geothermal Resources Council Transactions, Vol 22, September 20-23,1998.

Statistics NZ, 2002: Statistics New Zealand website: <http://www.stats.govt.nz>

Thain I., Reyes A.G. and Hunt T. (2006) A practical guide to exploiting low temperature geothermal resources. GNS Science Report 2006/09

Works Consultancy Services, 1990: Hydro resources of New Zealand.



## Appendix A Previously Identified Hydro Schemes

Scheme nos.	Catchment Area/River	Head	Mean Flow	Capacity	Energy <sup>(1)</sup>	Remarks
		(m)	(m <sup>3</sup> /s)	(MW)	(GWh)	
	<b>Wanganui</b>					
MW1	Tangarakau R <sup>(3)</sup>	54	3.2	1.7	7.4	
MW2	Wharawhara/Okauaka Stm	57	1.9	1.5	6.6	
MW3	Maramaraha Stm <sup>(3)</sup>	56	2.5	1.9	8.3	
MW4	Waione/Mangatukutuku Stm	59	2.6	2.1	9.2	
MW5	Ongarue River	83	3.1	3.87	17.0	
MW6	Ongarue River	29	3.1	1.35	5.9	
MW7	Waimiha/Koromiko Stm <sup>(3)</sup>	125	4.3	7.4	32.4	Alternative - 6.1 MW, 125 m head, 4.3 m <sup>3</sup> /s
MW8	Mangatapopo/Tawhitikuri Stm	88	1.5	1.9	8.3	
MW9	Wanganui River <sup>(3)</sup>	75	2.47	2.7	11.8	Alternative - 1.5 MW, 77 m head, 1.36 m <sup>3</sup> /s
MW10	Wanganui River <sup>(3)</sup>	91	1.4	1.8	7.9	
MW11	Wanganui River <sup>(3)</sup>	76	1.36	1.5	6.6	
MW12	Whakapapa <sup>(3)</sup>	144	7.3	15.3	67.0	
MW13	Piopiotea/Hakaratu Stm <sup>(3)</sup>	47	3.6	2.5	11.0	
MW14	Piopiotea/Makaretu Stream <sup>(3)</sup>	100	1.9	2.8	12.3	
MW15	Whakapapanui/Makahikato a Stm <sup>(3)</sup>	4343	6.3	3.9	17.1	
MW16	Makahikatoa Stm <sup>(3)</sup>	53	3.3	2.1	9.2	
MW17	Whakapapaiti Stm <sup>(3)</sup>	100	2.4	1.8	7.9	
MW18	Kakahi Stm	95	0.9	0.91	4.0	
MW19	Kakahi Stm	72	0.9	0.87	3.8	
MW43	Kakahi Stm		0.9	0.72	3.2	
MW21	Manganuiateao River/Orautoha R <sup>(3)</sup>	172	11.1	28.1	123.1	Alternatives - 21.3 MW, 154 m head, 11.1 m <sup>3</sup> /s 23.8 MW, 172 m head, 11.1 m <sup>3</sup> /s
MW20	Manganuiateao River	117	10.4	15	65.7	
MW22	Manganuiateao/Mangaturu turu R	240	3.3	9.8	42.9	
MW23	Waimarino <sup>(3)</sup>	107	4.2	5.6	24.5	



MW24	Retaruke <sup>(3)</sup>	57	2.2	1.4	6.1	
MW56	Atene <sup>(3)</sup>			400		MW72/MW73 – combined potential of 400 MW
MW57	Retaruke <sup>(3)</sup>					
	<b>Whangaehu – Turakina</b>					
MW25	Mangawhero R	14	14.4	2.4	10.5	
MW26	Mangawhero R	44	13.6	7	30.7	
MW27	Mangawhero R		9.1	7.3	32.0	
MW28	Makotuku R	89	3	2.6	11.4	
MW29	Mangawhero/Makotuku R	89	9.1	9.5	41.6	
MW30	Mangawhero R	28	6.1	2.7	11.8	
MW31	Makotuku/Makara R	70	1	0.64	2.8	
MW32	Makara/Orautoha	115	4.8	6.9	30.2	Alternatives - 2.5 MW, 115 m head, 1.73 m <sup>3</sup> /s 4.8 MW, 115 m head, 3.3 m <sup>3</sup> /s
MW33	Whangaehu	160	17.1	44	192.7	
MW34	Whangaehu	87	17.1	24	105.1	
MW35	Whangaehu	94	16.9	25.7	112.6	
MW36	Whangaehu	86	16.7	23.2	101.6	
MW37	Tokiahuru/Mangaehuehu/Mangawherawhera	12	9	12	52.6	
MW38	Tokiahuru/Mangaehuehu	8.4	8.3	8.4	36.8	
MW39	Tokiahuru/Waihurekeke	1.7	3.3	1.7	7.4	
MW40	Turakina/Mangapapa	3.2	8.3	3.2	14.0	
MW41	Mangaio	1.6	4	1.6	7.0	
MW58	Mangawhero-Wanganui			60		Dam on Mangawhero around Oreore, tunnel to PS on Wanganui
	<b>Rangitikei</b>					
MW42	Hautapu R	227	3.3	9.4	41.2	
MW44	Moawhango <sup>(3)</sup>	142	3.7	7.4	32.4	Alternatives - 9.4 MW, 227 m head, 3.3 m <sup>3</sup> /s 4.9 MW, 115 m head, 3.3 m <sup>3</sup> /s
MW45	Whakaurekoe	93	8.2		33.3	7.6 MW, Potentially conflicts with MW75
MW46	Hautapu R at Ohotu	69	5.1		19.3	4.4 MW, Potentially conflicts with MW75
MW47	Rangitikei at Ohinewaione	70	20		78.8	18 MW, Potentially conflicts with MW75



MW48	Kawatau at Upper Kawhatau	82	9.4	8.9	39.0	
MW59	Rangitikei <sup>(2)</sup>			310		9 schemes in the river reach 45 km to 195 km upstream from the mouth
	<b>Manawatu</b>					
MW49	Manawatu/Pohangina <sup>(3)</sup>	11.5	103	14	61.3	Alternative - 11.5 MW, 11.5 m head, 83 m <sup>3</sup> /s
MW50	Oroua/Pohangina <sup>(3)</sup>	290	11	33.5	146.7	Alternatives - 11.8 MW, 175 m head, 6.2 m <sup>3</sup> /s 19.5 MW, 290 m head, 6.2 m <sup>3</sup> /s
MW51	Oroua/Tunupa/Umutoi Ck	87	5.8	5.6	24.5	Alternatives 3.7 MW, 87 m head, 3.9 m <sup>3</sup> /s 4.8 MW, 87 m head, 4.9 m <sup>3</sup> /s
MW52	Pohangina <sup>(3)</sup>	231	6.5	15	65.7	Alternatives - 9.5 MW, 167m head, 5.7 m <sup>3</sup> /s 12.9 MW, 190 m head, 6.5 m <sup>3</sup> /s 11.4 MW, 210 m head, 5.7 m <sup>3</sup> /s
MW53	Pohangina <sup>(3)</sup>	270	4.8	13	56.9	
MW55	Pohangina <sup>(3)</sup>	109	7.6	9.6	42.0	
MW54	Makawakawa <sup>(3)</sup>	118	1.6	1.9	8.3	

(1) Flows to achieve 50% pf.

(2) Location unknown

(3) Potentially within or close to Department of Conservation land or National forests.



## Appendix B Resource Maps