

New Zealand Standard

Energy Efficiency – Installing Insulation in Residential Buildings

NZS 4246:2006



NZS 4246:2006

COMMITTEE REPRESENTATION

This Standard was prepared under the supervision of the P 4246 Committee the Standards Council established under the Standards Act 1988.

The committee consisted of representatives of the following:

Nominating Organisations

BRANZ
Department of Building and Housing
Eco Insulation
Employers' and Manufacturers' Association
Energy Efficiency and Conservation Authority (EECA)
Housing New Zealand Corporation
Insul-fluf Holdings Limited
Insulation Services Hawkes Bay
Insulpro Manufacturing Limited
Ministry for the Environment
Terra Lana Products

The amendment no.1 committee consisted of representatives of the following:

Nominating Organisations

BRANZ
Department of Building and Housing (DBH)
Eco Insulation
Energy Efficiency and Conservation Authority (EECA)
Expol Limited
Housing New Zealand Corporation
Insulation Specialists
Insulpro Manufacturing Limited
Tasman Insulation New Zealand Limited
Terra Lana Products

ACKNOWLEDGEMENT

Standards New Zealand gratefully acknowledges the contribution of time and expertise from all those involved in developing this Standard.

In particular, Standards New Zealand wishes to acknowledge the financial support of EECA, the Department of Building and Housing, BRANZ and Tasman Insulation, and the photographs and illustrations supplied by Insulpro Manufacturing, Eco Insulation, EECA, BRANZ and Tasman Insulation.

AMENDMENTS

No.	Date of issue	Description	Entered by, and date
1	April 2010	Amended to clarify requirements and incorporate information on new products	Incorporated in this reprint

NZS 4246:2006

Incorporating Amendment No. 1

New Zealand Standard

Energy efficiency – Installing insulation in residential buildings

Copyright Standards New Zealand

NOTES

Copyright Standards New Zealand

CONTENTS

Committee Representation	IFC	
Acknowledgement	IFC	
Copyright	IFC	
Referenced Documents	6	
Latest Revisions	6	
Foreword	7	
Review	7	
Section		
1 Introduction	9	
1.1 Objective	9	
1.2 Scope	10	
1.3 Compliance	11	
1.4 Interpretation	11	
1.5 Notes and commentary clauses	11	Amd 1 April '10
1.6 Referenced documents	11	
1.7 Definitions	12	
2 Insulation products	14	
2.1 Insulation products included	14	
2.2 Insulation products excluded	14	Amd 1 April '10
3 Special considerations	15	
3.1 Storage and transport	15	
3.2 Labelling	16	
3.3 Insulation compression	16	
3.4 Water damage	16	
3.5 Recessed light fittings (downlights)	17	
3.6 Recessed spaces (dropped ceilings)	18	
3.7 Heating appliance flues	19	
3.8 Electrical cables	19	
3.9 Built-in appliances and enclosures containing electrical equipment	19	
3.10 Plumbing	19	
3.11 Wall underlay	20	
3.12 Drained and ventilated cavities	21	
3.13 Access hatches	25	
3.14 Strapping	25	
3.15 Roof space ventilation	25	
3.16 Unducted fan units	25	
3.17 Unducted passive vents	25	
3.18 Insulation of cold and hot water pipes in ceiling spaces	26	Amd 1 April '10
4 Loose-fill	27	
4.1 Walls – unlined	27	
4.2 Pitched roof, flat ceiling	28	➤

Amd 1
April '10

Amd 1
April '10

Amd 1
April '10

Amd 1
April '10

Amd 1
April '10

Amd 1
April '10

Amd 1
April '10

5	Segments and blanket products.....	29
5.1	Ceilings – unlined.....	29
5.2	Ceilings – lined.....	31
5.3	Walls – unlined.....	34
5.4	Floors – new and existing.....	38
6	Rigid and semi-rigid sheets.....	40
6.1	Fixings.....	40
6.2	Pipes and plumbing.....	40
6.3	Electrical cables.....	40
6.4	Ceiling – unlined and lined.....	41
6.5	Walls – unlined.....	41
6.6	Underfloor – new and existing.....	42
7	Hot water cylinder wraps.....	45
8	On-ground vapour barriers.....	47
9	Pipe insulation.....	49
9.1	Fitting the insulation.....	49

Appendix

A	Climate zones (Informative).....	50
B	Health and safety (Informative).....	51
C	Effect of clearances on roof R-value (Informative).....	64
D	Summary of key changes in NZS 4246:2006 Amendment No. 1 (Informative) ..	66

Table

B1	Installing underfloor insulation with power on.....	60
B2	Installing underfloor insulation with power off.....	60
C1	Clearance 200 mm – Approximate reduction in R-value from R-3.0 by number of downlights per 10 m.....	64
C2	Clearance 200 mm – Approximate reduction in R-value from R-3.0 by distance between the centre of downlights.....	65
C3	Clearance 50 mm – Approximate reduction in R-value from R-3.0 by number of downlights per 10 m ²	65
C4	Clearance 50 mm – Approximate reduction in R-value from R-3.0 by distance between the centre of downlights.....	65

Figure

1	Recessed light fitting.....	18
2	Recessed ceiling space.....	19
3	Retrofitting wall underlay.....	20
3a	Roof detail for a low slope.....	23
3b	Skillion roof with metal tile cladding.....	23
3c	Low pitch roof with metal tiles.....	23
3d	Profiled metal roof.....	24
3e	Metal tile roof.....	24
4	Segments in unlined ceiling.....	30
5	Blanket in ceiling secured with strapping.....	31

6	Pitched roof – Segments installed in lined ceiling to top plate with continuous blanket overlaid by 150mm	32
7	Truss roof – Segment installed to top plate with full thickness blanket abutted to end of segment between truss.....	32
8	Blanket torn over the ceiling joist 300mm back from the top plate.....	34
9	Example of ‘tucking in’ showing undesirable compression of insulation at edges	35
10	Segments correctly installed in new wall installation	35
11	Tearing blanket to fit	36
12	Stapling blanket.....	37
13	Completed blanket installation in framed walls.....	37
14	Installing underfloor blanket	39
15	Installation of underfloor rigid floor insulation.....	42
16	Fitting semi-rigid sheets.....	44
17	Insulated hot water cylinder.....	46
18	Installing an on-ground vapour barrier.....	48
19	On-ground vapour barrier	48
A1	New Zealand climate zones.....	50
B1	When not to install underfloor foil insulation	59

Amd 1
April '10

Copyright Standards New Zealand

REFERENCED DOCUMENTS

Reference is made in this document to the following:

NEW ZEALAND STANDARDS

NZS 4214:2006	Methods of determining the total thermal resistance of parts of buildings
NZS 4218:2009	Energy efficiency – Housing and small buildings
NZS 4243 - - - Part 1:2007	Energy efficiency – Large buildings Building thermal envelope
NZS 4305:1996	Energy efficiency – Domestic type hot water systems

JOINT AUSTRALIAN/NEW ZEALAND STANDARDS

AS/NZS 4859.1:2002	Materials for the thermal insulation of buildings. Part 1 – General criteria and technical provisions
AS/NZS 3000:2007	Electrical installations (Australian/New Zealand wiring rules)

Other Publications

- BRANZ House Insulation Guide (current edition)
- BRANZ. Study Report SR 7. *A survey of moisture damage in southern New Zealand buildings*. Wellington: BRANZ 1988.
- How to choose the most efficient windows for your home: Window Efficiency Rating Scheme (WERS)(published by WANZ).

New Zealand Legislation

- Health and Safety in Employment (HSE) Act 1992
- Building Regulations 1992 (New Zealand Building Code (NZBC))

Latest Revisions

The users of this Standard should ensure that their copies of the above-mentioned New Zealand Standards are the latest revisions. Amendments to referenced New Zealand and Joint Australian/New Zealand Standards can be found on www.standards.co.nz.

FOREWORD

This Standard is intended to provide clear and sound guidance to installers of insulation to ensure that the design thermal performance and thermal durability of the building element is achieved.

New Zealand has become very aware of the importance of healthy homes and conservation of energy as part of the move to sustainable building. Insulation correctly installed plays a large part in ensuring efficient use of energy and a healthy internal environment in New Zealand buildings.

If insulation is installed incorrectly, e.g. with gaps, tucking in, or folds, is compressed, bent or becomes wet, the thermal resistance and the durability of insulation will be reduced.

Correctly installing insulation in buildings is critical if thermal performance is to be optimised. This Standard details installation methods for specified insulation which, when followed, will ensure that the design thermal performance is achieved. Although vapour barriers are not, in themselves, methods of insulation, they have been included as a means of protecting and enhancing the performance of insulation products.

As there are a number of concerns with reflective pliable membranes the P 4246 A1 committee has removed the section on installation of these materials from the Standard. The research data gathered to date identified the following issues with installation of these products in residential houses:

- (a) Safety. Reflective pliable membranes that conduct electricity (e.g. metallic foil) pose a number of electrical safety risks for installers and house occupants. To some extent, mitigation of these risks is covered in Appendix B of the Standard. However, following these recommendations cannot guarantee the safety of installers, tradespeople and house occupants should they come in contact with these membranes at any stage during the life of the house. The committee agreed that the original content of Appendix B should remain in the Standard for future reference;
- (b) Variable performance. The in situ thermal performance of reflective pliable membranes is highly variable and depends on many factors including changing temperatures, dust, ventilation, surface corrosion, drap height, etc;
- (c) Lack of durability. It is unlikely that most of these products will last even 15 years (NZBC Clause B2 Durability requires 50 years), particularly in exposed or semi-exposed underfloor installations;
- (d) Creating a moisture barrier. Attempts to improve the performance of installations with reflective pliable membranes increase the risk of condensation forming on top of the membrane. Consequently, thermal performance of the membrane will be undermined as well as durability of adjacent building elements (floor joists, floor boards).

In addition, the committee also concluded that while reflective pliable membranes were cost-effective compromises in the absence of better alternatives when first introduced, better alternatives have recently become available on the market, making further use of reflective pliable membranes unnecessary.

To assist users familiar with NZS 4246:2006, Appendix D provides a summary of the key changes as a result of Amendment No. 1.

REVIEW

Suggestions for improvement of this Standard will be welcomed. They should be sent to the Chief Executive, Standards New Zealand, Private Bag 2439, Wellington 6040.

NEW ZEALAND STANDARD

ENERGY EFFICIENCY – INSTALLING INSULATION IN RESIDENTIAL BUILDINGS

1 INTRODUCTION

1.1 Objective

NZE 4246 provides guidance to insulation installers in order to achieve the design thermal performance and durability of building elements, as well as minimising the risk to installers.

1.2 Scope

1.2.1 Inclusions

The Standard covers methods of installing common insulation products in common residential construction types, and information on the safe installation of insulating materials is appended.

Amd 1
April '10

Loose-fill products are included, but only to the extent of generic guidelines. On-ground vapour barriers have been included although they are not, in themselves, insulation products, because keeping ground moisture out helps to keep indoor air dryer, reducing condensation and improving the quality of the living environment.

Amd 1
April '10

The detail in the Standard is based on residential-type construction, but the methods may be appropriate to other constructions.

The Standard covers both the installing of insulation in new buildings during construction and the retrofitting of insulation in existing buildings.

1.2.2 Exclusions

This Standard excludes installation of:

- (a) Structural elements of buildings that provide thermal resistance by any particular building material or part of a building. Information on thermal resistance may be found in NZS 4214, NZS 4218, NZS 4243.1, NZS 4305 and the BRANZ House Insulation Guide;
- (b) Insulation in buildings with specific design, including freezers or cool stores;
- (c) Insulation in buildings where insulation is part of the cladding material, e.g. exterior insulation and finish systems (EIFS);
- (d) Insulation for purposes other than for thermal benefit, e.g. acoustic;
- (e) Vapour barriers where these may be required in building elements around areas such as spa pools, swimming pools or mountain lodges;
- (f) External applications;
- (g) Pre-assembled insulating systems;
- (h) Double-glazing (for further information on glazing and *R*-values, see NZS 4218 and the WERS guide);

▶
Amd 1
April '10

- (i) Expanding in situ foams;
- (j) Radiant barriers in walls and ceilings;
- (k) Slab on ground; and
- (l) Reflective pliable membranes.

Amd 1
April '10

1.3 Compliance

1.3.1 General

Insulation is the main component in the make-up of any compliant construction *R*-value and helps to achieve compliance with the New Zealand Building Code (NZBC) Clause H1.

The current NZBC clauses that are relevant for thermal insulation are outlined below.

Amd 1
April '10

1.3.2 Energy efficiency

NZBC Clause H1 sets an energy performance level for housing. An acceptable solution for housing and other small buildings is provided through the NZBC Compliance Documents.

1.3.2.1 Selecting levels of insulation

New Zealand is divided into three climate zones to determine appropriate insulation requirements for various building elements. NZS 4218 defines these climate zones.

See Appendix A for a New Zealand climate zone map.

Amd 1
April '10

Amd 1
April '10

1.3.3 Prevention of fungal growth

The Acceptable Solution to NZBC Clause E3 Internal Moisture requires the insulation of exterior walls and ceilings of habitable spaces, and the exterior walls and ceilings of wet area rooms of housing. This is to ensure internal surface temperatures can be maintained at levels that reduce the likelihood of condensation and consequent fungal growth on building elements. Achieving the *R*-values specified is highly dependent on the quality of the installation.

1.3.4 Durability of insulation

In the context of this Standard insulation products are required to not only be structurally durable but also to maintain their claimed thermal performance for the service life of the product. NZBC Clause B2 requires that building products continue to provide compliance with the other clauses of the NZBC for varying prescribed lengths of time depending on their function, accessibility, ease of replacement and detection of failure.

Failure of insulation thermal resistance on site is difficult to measure. Thus, regardless of its ease of access and replacement, thermal insulation is required to have a durability of not less than 50 years. Refer to NZBC Clause B2.

For example: loose-fill products will almost always experience some settling after installation and therefore the product must be installed in such a way that the claimed thermal performance will still be achieved at the point when it is expected to be serviced. In practice this would require the product to have an initial thermal performance above the claimed value to allow for the inevitable settling.

NOTE – The ingress of moisture, settlement, air movement, and slight movement of materials encasing the insulation are some of the causes of deterioration of insulation products or their installation.

Amd 1
April '10

Amd 1
April '10

Amd 1
April '10

Amd 1
April '10

Amd 1
April '10

1.3.5 Risk of fire

Insulation shall not be installed in such a manner that a fire risk is created. For heating appliances, chimneys and flues, minimum clearances shall be maintained in accordance with Acceptable Solution C/AS1, of Compliance Document for NZBC Clause C.

Amd 1
April '10

1.4 Interpretation

For the purposes of this Standard the word 'shall' refers to practices that are mandatory for compliance with this Standard. The word 'should' refers to practices which are advised or recommended.

The term 'Informative' is used in this Standard to define the application of the Appendix to which it applies. An 'Informative' Appendix gives additional information, and is only for guidance. It does not contain requirements.

Amd 1
April '10

1.5 Notes and commentary clauses

1.5.1 Notes

Clauses prefixed by 'NOTE' are intended as comments on the corresponding mandatory clauses. They are not to be taken as the only or complete interpretation of the corresponding clause nor should they be used for determining in any way the mandatory requirements of compliance within this Standard.

Amd 1
April '10

1.5.2 Commentary clauses

Clauses prefixed 'C' and printed in italic type are intended as comments on the corresponding clauses. They are not to be taken as the only or complete interpretation. The Standard can be complied with if the comment is ignored.

Amd 1
April '10

1.6 Referenced documents

The full titles of reference documents cited in this Standard are given in the list of Referenced Documents immediately preceding the foreword.

1.7 Definitions

Amd 1
April '10

BLANKET. Non-rigid insulation product provided in a roll. The roll may be available in varying widths, lengths and thickness.

Amd 1
April '10

FORMED-IN-PLACE. Insulation products that change in composition or physical properties during or immediately after installation. Examples are sprayed foam and adhesive stabilised loose-fill.

Amd 1
April '10

HOT WATER CYLINDER WRAPS. Comprised of a blanket insulation product with a cotton or foil exterior.

IN SITU FOAMS. Formed in place insulation made from foam that expands in place.

INSULATION MATERIAL. Indicates a product that gains its properties once it is installed.

INSULATION PRODUCT. A commodity that is produced by manufacture or by a natural process and is offered for sale.

LOOSE-FILL. Insulation that is in the form of small particles or fibres that are blown into place.

MINERAL WOOL. Fibrous insulation made from inorganic oxides or minerals, rock slag or glass. The most commonly used mineral wool insulations are glass wool and rock wool.

PIPE INSULATION. Insulation products designed for insulating pipes.

PITCHED ROOF. Roof constructed with a space between the rafters and ceiling joists/truss chords where the ceiling and the roof are not parallel.

R-VALUES. The value of thermal resistance of a building element (e.g. wall, floor or roof) which is the sum of the surface resistances on each side of a building element and the thermal resistances of each component of the building element including any cavities in the element. It is determined by calculation or by measuring the temperature difference between the internal air on one side and the external air on the other side of a building component, when there is unit heat flow in unit time through unit area using internal and external conditions considered as typical for buildings ($m^2 \cdot ^\circ C/W$).

RECESSED LUMINAIRE/RECESSED LIGHT FITTING. A light fitting intended by the manufacturer to be fully or partly recessed into a mounting surface such as a floor, wall or ceiling.

REFLECTIVE INSULATION. A product with one or more low emissivity layers attached to bulk insulation.

REFLECTIVE PLIABLE MEMBRANES. Products with one or more low emissivity layers.

RIGID SHEET INSULATION. Insulation in the form of a rigid board that cannot be folded or bent but must be cut to fit into place. These are usually of rigid cellular plastic.

SEGMENTS. Also known as pieces or pre-formed shapes. Non-rigid insulation product pre-cut to small standard units. The pre-formed shape may be available in varying sizes and thickness.

SEMI-RIGID SHEET INSULATION. Insulation in the form of sheets that are self-supporting on a vertical or horizontal plane, but can be folded when required. This type is a firm but flexible insulation product that is of a medium to high density.

Amd 1
April '10

Amd 1
April '10

Amd 1
April '10

Amd 1
April '10

Amd 1
April '10

SKILLION ROOF. A pitched roof where the ceiling lining is parallel and close to the roof cladding. The roof may consist of more than one roof plane. The rafters may or may not be exposed below the ceiling.

THERMAL RESISTANCE (R). A measure of resistance to the flow of heat. It can be determined by measuring the temperature difference which is maintained between surfaces or planes when there is constant heat flow between them in unit time through unit area ($\text{m}^2 \cdot ^\circ\text{C}/\text{W}$).

Amd 1
April '10

TOTAL THERMAL RESISTANCE (R_T). The total thermal resistance, including surface thermal resistances, between the air on either side of a building element.

WOOL. Wool derived from the fleece of a sheep, or animal with similar fibres.

Amd 1
April '10

2 INSULATION PRODUCTS

There is a variety of types of insulation products which may take various product forms. Ensure that the insulation product chosen is deemed 'fit for purpose' by the manufacturer for that application. Refer to the manufacturer's technical literature for further information.

Only some of these types of insulation are covered by this Standard.

2.1 Insulation products included

The following insulation products and applications are covered by this Standard:

- (a) Loose-fill product, (e.g. wool, rock wool, glass wool or cellulose fibre);
- (b) Segment and blanket products, (e.g. wool, rock wool, glass wool, polyester);
- (c) Rigid sheet products, (e.g. expanded or extruded polystyrene (EPS or XPS));
- (d) Semi-rigid insulation, (e.g. wool, rock wool, glass wool, polyester);
- (e) Pipe insulation, (e.g. pre-formed tubular foam);
- (f) Hot water cylinder wrap, (e.g. wool, glass wool or polyester blanket with cloth or foil backing).

2.2 Insulation products excluded

The following insulation products are not covered by this Standard and are excluded:

- (a) Any in situ foam product;
- (b) Any product with a reflective insulation layer used in the roof, ceiling or walls;
- (c) Sub-floor reflective insulation, (e.g. foil).

3 SPECIAL CONSIDERATIONS

This section describes some areas where special care shall be taken when handling and installing insulation.

Amd 1
April '10

The total *R*-value of a building element e.g. wall, floor or roof is the sum of the surface resistances on each side of a building element and the thermal resistances of each component of the building including any cavities and the representative structure of the building element less the effects of any thermal bridging.

In practice the total *R*-value of a building element will depend to a large extent on the *R*-value of the insulation product installed and the quality of the installation itself. In order for building elements to meet the *R*-values in NZS 4218, NZS 4243.1 or the building design, insulation must be installed correctly.

Amd 1
April '10

Insulation is an important part of the building envelope and as such is required to interface with other building elements and fittings. The effect of poor installation, e.g. folds, tucking in and gaps will reduce the effectiveness of insulation. Gaps around the edges of insulation, either on all four edges or with gaps on both sides and a double height gap at the top, will reduce the effective *R*-value of the insulation by approximately 3% for every 1mm gap. For example with 16mm gaps the material *R*-value of the insulation should be assumed to be half of the nominal *R*-value ($16 \times 3\% = 48\%$). The occurrence of face gaps in conjunction with edge gaps is even more detrimental to thermal performance and should be avoided at all cost as the thermal performance of the insulation is likely to be completely negated. Face gaps will occur if the nominal thickness of the insulation is less than the depth of the frame cavity or if in situ foam shrinks. Settlement of loose-fill will result in a gap on the top edge only and in those cases the reduction in *R*-value of the insulation material should be assumed to be 1% for every 5mm of settlement.

Amd 1
April '10

Prior to the installation of any insulation product, the installer shall be satisfied that conditions within the building are appropriate for the installation to begin. This includes checking that:

Amd 1
April '10

- (a) There is sufficient space available for the insulation to achieve its designed thermal performance;
- (b) The final cladding material has been installed (if a new building);
- (c) There is provision for insulation support, or where required for installation the support is in place;
- (d) In existing buildings, no obvious leaks are present; and
- (e) The moisture content of timber is 20% or less.

Amd 1
April '10

Information on the health and safety aspects of installing insulation is set out in Appendix B.

3.1 Storage and transport

All insulation products shall be protected from the weather until use and be undamaged and dry when installed.

Amd 1
April '10

Insulation products shall be top stowed only and shall not have products loaded on top of them on-site either temporarily or permanently, e.g. insulation bales shall not be used as seating.

Amd 1
April '10

3.2 Labelling

All installations shall have a product label in accordance with AS/NZS 4859.1, permanently fixed on site where it can be easily found for future inspection. This includes:

- (a) Product name;
- (b) Description of contents;
- (c) Name and address of manufacturer and installer;
- (d) Declared *R*-value;
- (e) Nominal coverage (area per unit mass);
- (f) Stabilised thickness (mm); and
- (g) Nominal net weight of contents or supplied quantity (kg).

Amd 1
April '10

3.3 Insulation compression

One of the main components in achieving the design *R*-value of a bulk insulation product is design thickness. It is critical to product performance that when installing any given product, the design thickness is known and achieved in order for the design *R*-value to be met.

Insulation products shall be installed in a cavity at least sufficiently large to accommodate the design thickness plus any required clearance. Compressing the insulation into a cavity smaller than the design thickness will reduce its actual delivered *R*-value approximately in direct relation to the amount compressed, e.g. compressing a product that delivers *R* 2.0 at 100mm down to 80mm will result in an *R*-value of approximately 80% of 2.0, or 1.6. This means it is important to ensure that the insulation has room to remain at its designed thickness.

Amd 1
April '10

Amd 1
April '10

3.4 Water damage

All insulation affected by dampness and water damage, including insanitary and unsafe material, shall be removed and/or remediated. The source of moisture/water ingress shall be identified and made good. All cavities and materials shall be dried and cleaned of contaminants, mould and mildew and treated with approved solutions prior to the installation of new insulation products.

If in doubt, advice shall be obtained from a suitably qualified building consultant before insulation is installed.

3.4.1

Where a reflective pliable membrane has been installed as a roof underlay, insulation shall not be installed and the home owner/occupier shall be advised.

Amd 1
April '10

C3.4.1

It is not uncommon to find foil-based (non-absorbent) products used as roof underlays. Such products may be non-compliant in new housing because Acceptable Solution E2/AS1, of Compliance Document for NZBC Clause E2 requires absorbent roofing underlays.

Water damage of insulation in roof spaces is not uncommon and is generally caused by one or a combination of:

- (a) Roof leaks;*
- (b) An excess of 'construction moisture' (wet framing timber) being present during or at the completion of construction; and/or*
- (c) Air from a conditioned space which is suspending moisture, is allowed to pass into an 'unconditioned' area, such as a roof space.*

In (c) any moisture carried into the roof space will condense on any non-absorbent material and be released directly onto the insulation and ceiling below.

3.5 Recessed light fittings (downlights)

Recessed light fittings compromise the effectiveness of ceiling insulation due to the required clearance of insulation around the light fitting and possible air movement through the fitting itself.

NOTE – Appendix C provides guidance on reduction in the *R*-value of the ceiling depending on the number of downlights per 10m².

3.5.1 Clearance between downlight and insulation

Important: Insufficient clearances around recessed light fittings substantially increase the risk of fire. Under no circumstances shall insulation be installed over the top of downlights and their auxiliary equipment (such as transformers).

If the manufacturer's specified clearances for downlights are known they shall be followed. If they are not known then clearance in accordance with figure 1 shall be made.

Where the type of lamp in accordance with figure 1 cannot be determined, a minimum clearance of 200mm shall be made between the downlight and insulation material.

Amd 1
April '10

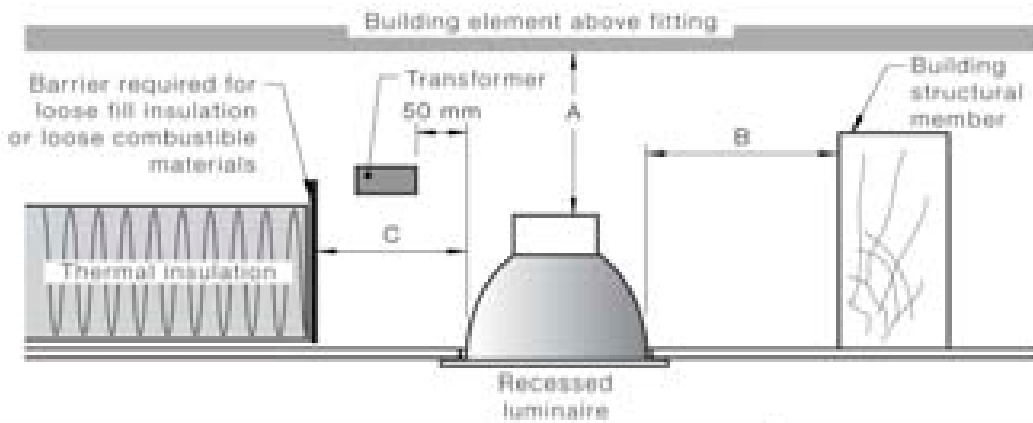

Dimension	Incandescent lamp	Halogen lamp
A - Clearance above luminaire	50 mm	200mm
B - Side clearance to structural member	100 mm	200 mm
C - Clearance to thermal insulation	50 mm	200 mm
D - Clearance to supply transformer	50 mm	

NOTE – Figure 1 has been reproduced from AS/NZS 3000.

Figure 1 – Recessed light fitting

Where insulation is retrofitted to the existing ceiling, any old insulation shall be cleared away from the downlight to maintain the required clearance.

Clearances for loose-fill insulation shall be set by placing around the light a cylindrical open ended collar. The collar shall be made of rigid material, extending at least 75mm above the installed insulation layer and be permanently fixed to prevent dislodgement when installing insulation.

NOTE – Installation of combustible loose-fill product where there are recessed lights fittings is not recommended.

3.5.2 Auxiliary equipment

Insulation shall not be installed over the top of auxiliary equipment e.g. transformers. A clearance shall be maintained between the transformer and the luminaire at the minimum distance set out in the manufacturer’s installation instructions or in accordance with figure 1.

3.6 Recessed spaces (dropped ceilings)

Insulate down walls and across recessed ceilings (e.g. bathrooms and internal wardrobes) (see figure 2). Soffit or porch areas shall not be covered with insulation.



Figure 2 – Recessed ceiling space

3.7 Heating appliance flues

A clearance of 50mm shall be left around metal chimneys and flues where they penetrate a wall or ceiling.

NOTE – Acceptable Solution C/AS1 paragraph 9.4, of Compliance Document for NZBC Clause C requires a ventilated space of 50mm between the outer face of a fireplace or chimney and any insulation product.

Amd 1
April '10

3.8 Electrical cables

Care shall be taken to avoid damaging electrical cables and/or equipment. Refer to a registered electrical worker for further guidance.

Amd 1
April '10

3.9 Built-in appliances and enclosures containing electrical equipment

If built-in appliances or enclosures containing electrical equipment are present in the space to be insulated, thermal insulation shall not be placed around the appliance or enclosure. Built-in appliances include heaters, ovens and stoves.

Amd 1
April '10

3.10 Plumbing

Install insulation around the plumbing whilst ensuring minimal disruption to the plumbing.

Amd 1
April '10

3.11 Wall underlay

In retrofit situations, before installing insulation in the wall cavity, there shall be a check for signs of moisture in the wall cavity. If there are any signs of moisture in the cavity the cause of this shall be remedied before insulation is installed.

If there are no signs of moisture entering the cavity and a wall underlay is in place and in good condition, insulation can then be installed in the wall cavity.

If there are no signs of moisture in the cavity and there is no wall underlay in place, a wall underlay shall be installed following the details shown in figure 3, before insulation material is installed in the wall cavity.

C3.11

Before retrofitting wall insulation in an existing building it is good practice to assess the weather tightness risk for the location, design and cladding type. See Acceptable Solution E2/AS1, of Compliance Documents for NZBC Clause E2 for more details.

A wall underlay installed in the way described in figure 3 will create a still air space and help protect the insulation from absorbing any moisture or condensation from the inside of the wall cladding. It will not provide a secondary line of defence for weather tightness. This method is not to be used for new construction and is a compromise to best practice, based on what can practically be achieved in some retrofit situations.

Acceptable Solution E2/AS1, of Compliance Document E2, contains information on the properties of roof underlays and building wraps, and should be consulted for the selection of an appropriate wall wrap.

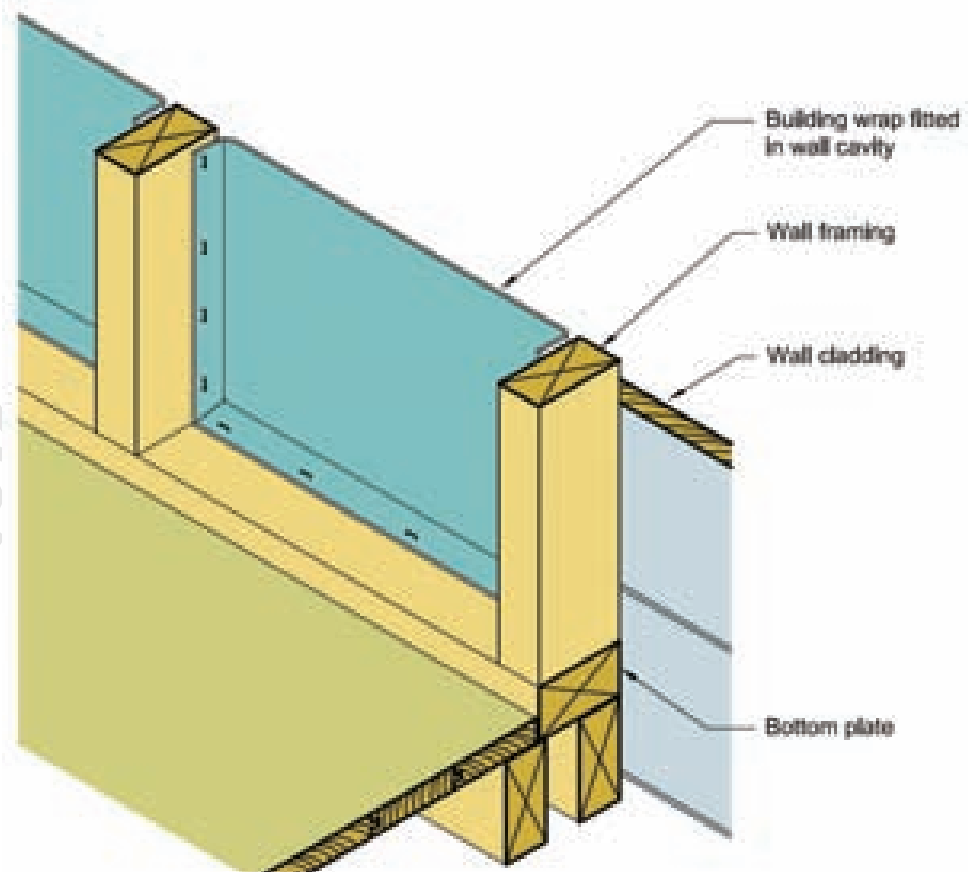

Figure 3 – Retrofitting wall underlay

NOTE – The procedures outlined in this section are best practice for retrofitting wall underlay, in preparation for the fitting of insulation in a typical timber-framed construction dwelling where the timber frame and structure is dry (as in Acceptable Solution E2/AS1, of NZBC Clause E2 External moisture).

As there are many different types of construction, and means of achieving weather tightness, installers and contractors should use their discretion, or seek advice from a suitably competent building consultant or building contractor for the best method to ensure a suitable wall underlay is in place to keep the insulation dry.

Amd 1
April '10

3.12 Drained and ventilated cavities

The nominal thickness specified on the pack label of compression packaged fibrous insulation products is not necessarily the actual thickness of the product once it is installed. Sometimes the products will loft to a thickness that is greater than the nominal value and the lofting can take a few months and may not be completed until the building experiences a summer climate. Uncertainty about installed thickness can have implications in situations where there is a need to maintain a cavity adjacent to the insulation. If, during the installation process such issues become apparent, then the product shall not be installed and the designer shall be consulted. Required ventilated cavities shall not be filled with insulation product.

Amd 1
April '10

The most common situations are:

- (a) Wall systems which include a cavity between the exterior cladding and the insulated frame space to allow for drainage and/or ventilation;
- (b) Skillion and low slope roof systems where there is a need to have a cavity of a minimum of 25mm between the top surface of the insulation and the underside of the roof (and underlay) to prevent the wicking of moisture into the insulation; and
- (c) Around the perimeter of the roof space under a pitched roof where there is limited space between the underside of the roof (and/or underlay) and the ceiling. This is also to prevent the wicking of moisture.

Amd 1
April '10

Amd 1
April '10

3.12.1 Wall systems with a cavity behind the cladding

Usually there is an underlay covering the framing and insulation. To maintain the cavity between the frame and the exterior cladding it is important that the insulation is a good fit in the frame space and that the insulation does not loft to the extent that it bulges (even with the restraint from the underlay) into the cavity.

To achieve a good fit, and to also prevent insulation sag in the frame space, segment or blanket insulation needs to touch on all six faces including against the underlay and against the interior lining. To prevent the insulation from bulging out into the cavity the actual thickness of the insulation and the thickness it would have eventually lofted to when unrestrained, shall be no more than 10% greater than the width of the frame space into which it is installed.

Amd 1
April '10

C3.12.1

For example, if 90mm framing is used the insulation thickness would therefore need to be a recovered thickness of no more than 100mm nominal thickness to prevent bulging and to maintain a ventilated cavity, but at least 90mm to prevent sag.

Amd 1
April '10

3.12.2 Around the perimeter of the roof space under a pitched roof

Around the perimeter of the roof space it is important to allow for lofting of the insulation after installation to prevent the insulation touching the underside of the roofing product or underlay. A minimum gap of 25mm needs to be maintained between the insulation and the underside of the roof (or underlay) to prevent wicking of water into the insulation. One means to achieve this is to fix a rigid product to the underside of roof framing as a physical restraint to the insulation loft.

Amd 1
April '10

Amd 1
April '10

Amd 1
April '10

3.12.3 Beneath a skillion or low slope roof

Beneath a skillion or low slope roof it is important to allow for lofting of the insulation after installation. To ensure that a minimum cavity height of 25mm is retained between the top of the insulation and the underside of the roof (and underlay), even after summer heat exposure, either the insulation shall be physically restrained by wire mesh or an insulation product used for which the installed maximum loft is known.

Figures 3(a) to (e) are typical roof construction details illustrating common framing configurations at the roof framing/ exterior wall framing junctions. Except for figure 3(a) they are all dimensioned for 'worst case' scenarios i.e. climate zone 3 with exterior walls of 'solid' construction (excluding solid timber).

NOTE – For new roofs the insulation type must be determined before the roof design is undertaken so that the size of the framing members can be specified to accommodate the thickness of the insulation in addition to the minimum 25mm clearance required between the insulation and any non-rigid roofing underlay.

Figure 3(a) is a likely existing framed roof detail for a low slope roof. In the case of tiled roofs (metal or masonry) the underlay will always be installed to the underside of the tile battens which reduces the available space for insulation.

NOTE – It will not always be possible to retrofit insulation in existing houses to the same standards as new housing due to the constraints of the sizing of existing framing members.

Figure 3(b) is a typical low slope skillion roof with metal tile cladding.

Figures 3(c), 3(d) and 3(e) are timber trusses which have been manufactured specifically to accommodate the specified thickness of insulation and roof underlay separation.

Amd 1
April '10

Amd 1
April '10

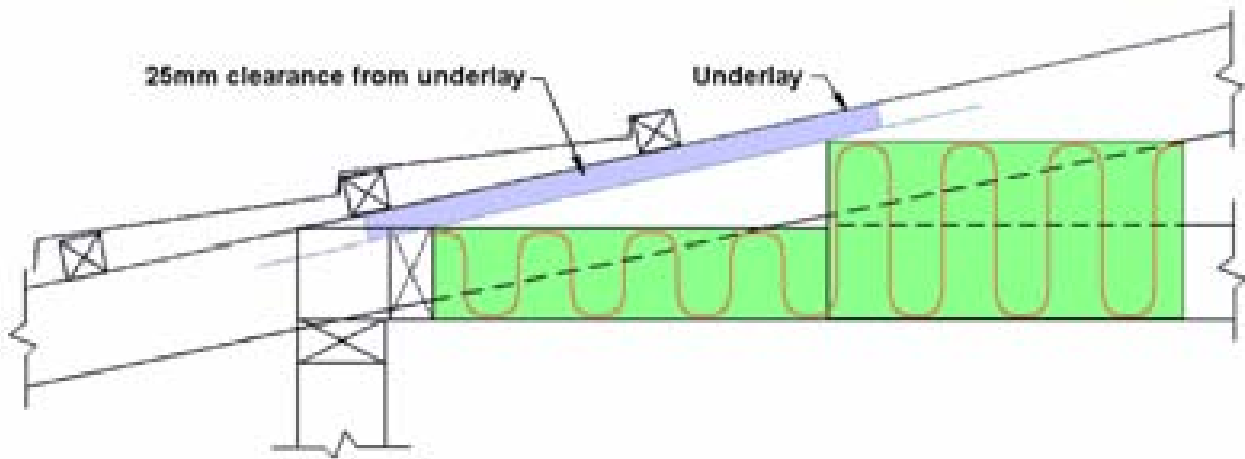

Figure 3(a) – Roof detail for a low slope

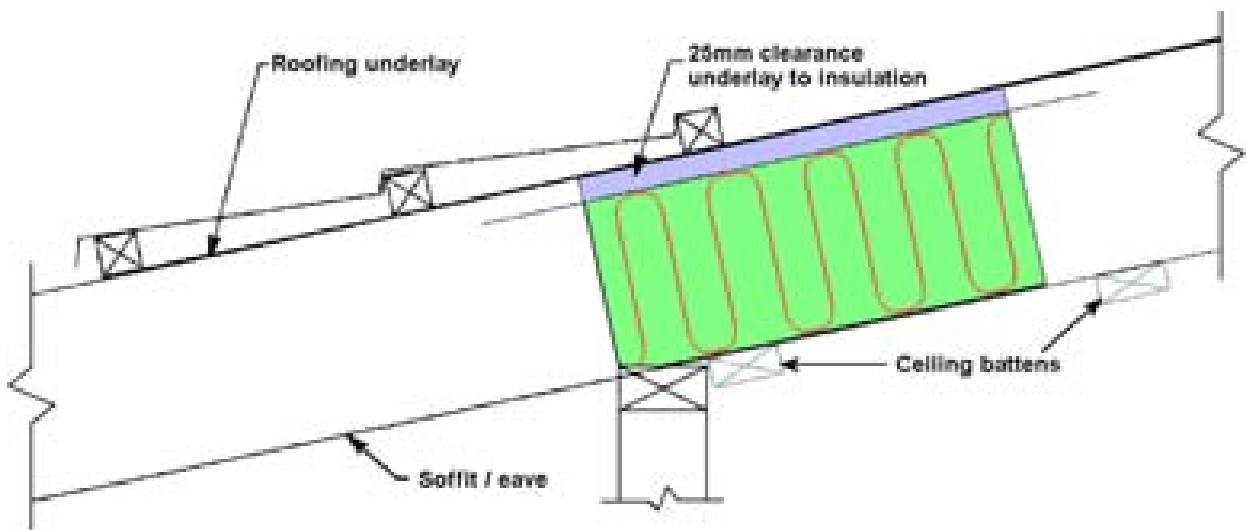

Figure 3(b) – Skillion roof with metal tile cladding

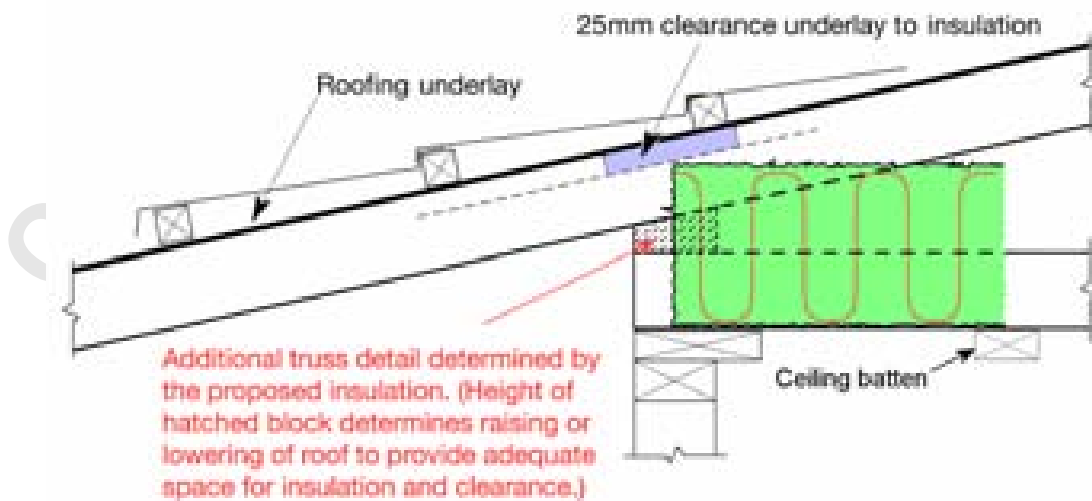

Figure 3(c) – Low pitch roof with metal tiles

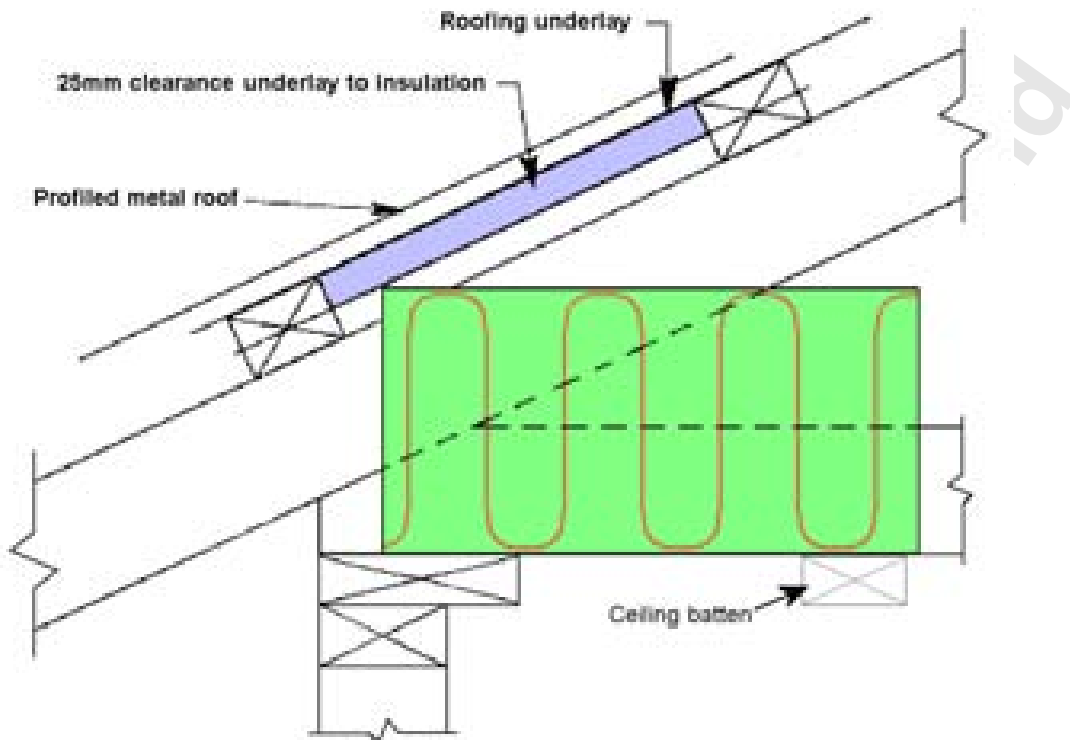

Figure 3(d) – Profiled metal roof

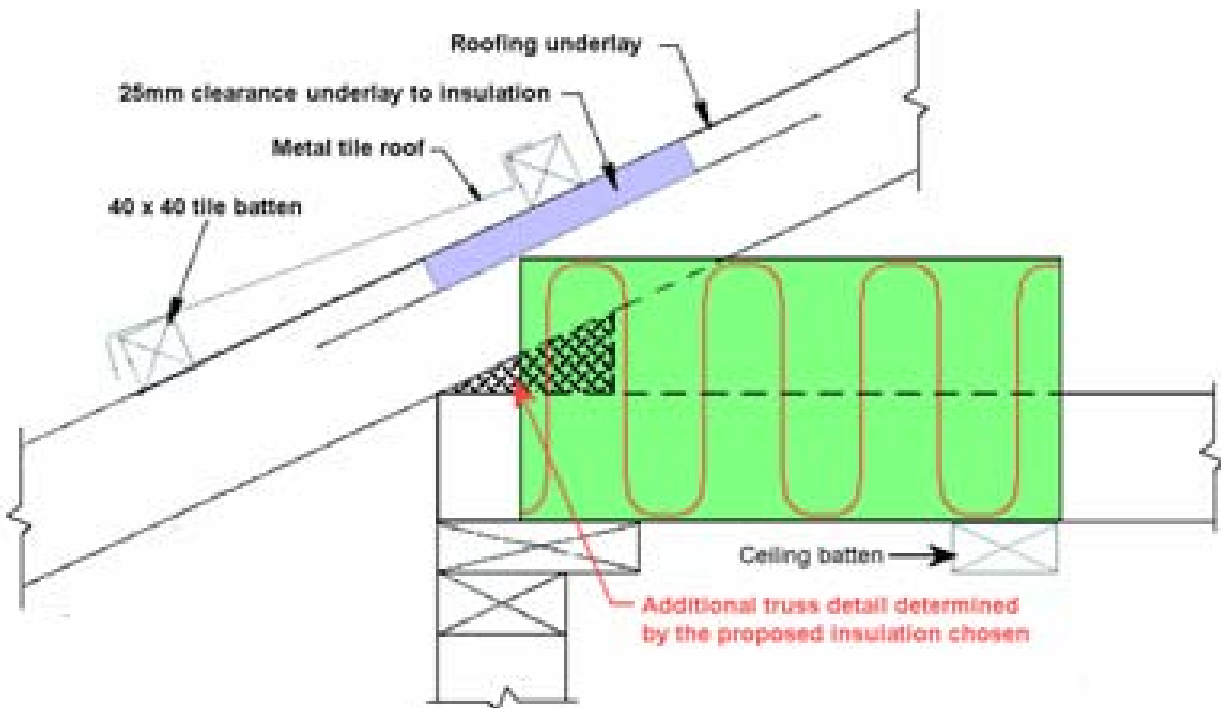

Figure 3(e) – Metal tile roof

3.13 Access hatches

Access hatches shall be insulated with a separate piece of insulation, which shall be permanently fixed to the top of the hatch (stapled or glued) without undue compression.

Amd 1
April '10

3.14 Strapping

To ensure permanent placement of segment and blanket insulation, strapping shall be used for all walls which will not be lined, for example, in an internal wall adjacent to the ceiling or underfloor area. Sufficient strapping shall be used to ensure permanent placement of the insulation and be fixed horizontally at no more than 300mm centres.

3.15 Roof space ventilation

Houses may have mechanical or passive ventilation systems in the form of fans, ductwork, and/or vents. Where mechanical or passive ventilation systems are ducted to the exterior of the building and/or fully ducted, insulation shall be fitted against the outside wall of the duct. If the mechanical or passive ventilation is not ducted to the exterior of the building, care shall be taken to ensure that thermal insulation does not enter open fan units or vents, which are installed in ceilings.

3.16 Unducted fan units

A clearance of 200mm shall be maintained around open fan units to contain the insulation when installed in ceilings.

Home owners shall be notified that the fan unit is unducted and that the insulation shall be kept clear of the fan unit as required by 3.16.

3.17 Unducted passive vents

Subject to approval from the home owner, passive (non-mechanical) vents that open into the roof space shall be sealed and insulation installed to cover the vents. The vents shall be sealed using plastic sheet taped over the top-side of the vent to form an air-tight seal, or covered with a piece of plastic (insulation bale wrap is acceptable) at least three times the size of the vent, positioned as near as practical over the centre of the vent, fitted under the insulation.

Where passive vents must remain functional, a contained clearance of 200mm shall be maintained around the vents for the insulation.

Amd 1
April '10

C3.17

The home owner should be advised that passive vents and unducted fans may:

- (a) Allow insulation and other particles from the roof space to enter the interior during windy weather;*
- (b) Allow warm air from inside to escape (making the room hard to heat);*
- (c) Transfer excessive moisture into the roof space (compromising the performance of the insulation by increasing the amount of roof condensation);*
- (d) Reduce condensation inside by allowing the internal moisture to escape.*

A recommendation should be made to the home owner to:

- (e) Duct fans to the exterior of the building and then fully insulate the ceiling;*
- (f) Seal passive vents or duct to the exterior of the building, and then fully insulate the ceiling.*

3.18 Insulation of cold and hot water pipes in ceiling spaces

In climate zone 3 (see Appendix A for the map of New Zealand climate zones) the entire length of all water pipes protruding above ceiling insulation shall be insulated in accordance with section 9.

NOTE – Installing insulation reduces the rate of heat losses through the ceiling. In houses situated in areas subject to temperatures below 0°C, particularly those with header tanks (low pressure hot water), introduction of ceiling insulation can cause freezing of water pipes protruding above the insulation.

4 LOOSE-FILL

This section details methods of insulation for loose-fill products in walls and ceilings in new and existing constructions. Loose-fill materials shall be installed by professional applicators, who are trained in using particular product types to the specifications of the manufacturer. Ventilated cavities shall not be filled with loose-fill materials.

Amd 1
April '10

Before starting installation, investigate the conditions of the job and plan accordingly. Take into account:

- (a) Safety factors;
- (b) Difficult access areas (low pitched roof, behind ceiling runners, etc.);
- (c) Chimneys and flues;
- (d) Recessed light fittings;
- (e) Air conditioning/other ducted systems/vents;
- (f) Water heaters/header tanks; and
- (g) Recessed spaces.

4.1 Walls – unlined

The following steps shall be taken when installing loose-fill insulation in unlined walls. Any required electrical and plumbing work shall be completed before insulation is installed. Any obvious signs of water ingress shall be investigated and remedied prior to installation.

Amd 1
April '10

Step	Action
1.	Define total weight of material required for the area on the basis of the area of the wall, allowing for framing and depth of stud.
2.	The wall cavity shall be filled and suitable adhesive shall be included as recommended by the manufacturer as compatible with other building products.
3.	The face of the insulation shall be dressed flush after installation.
4.	Allow appropriate drying time to ensure that the loose-fill material and any adjacent framing is dry. See section 3 (e) for maximum permitted moisture content of not greater than 20% for framing which will equally apply post installation of the insulation and before installing wall linings. NOTE – Drying time will vary depending on materials used and local climatic conditions. Drying time depends on the solvent, whether water or spirit based.

Amd 1
April '10

Amd 1
April '10

4.2 Pitched roof, flat ceiling

Step	Action
1.	Any existing insulation shall be levelled and any damp insulation removed, see 3.4. Any displaced existing insulation shall be refitted prior to commencing work.
2.	Insulation shall be installed from the edges, back into the centre and to the hatch (to minimise disturbance of product already laid).
3.	Adjust the machine setting as necessary to ensure constant material density, particularly if pumping over longer than usual distances or above usual height, e.g. above two stories.
4.	Use rigid pipes as necessary to access areas inaccessible by other means.
5.	Use a blowing machine that has the facility for separate adjustment of both air and material flow.
6.	Material shall be of an even depth throughout the ceiling. Levelling markers or posts shall be used showing installed level.
7.	There shall be a total cover of the ceiling including at least 50% of the exterior wall top plate (except where obstructed by other framing members e.g. ceiling joists) ensuring minimal overflow into eaves.
8.	All space below bracing timbers (ceiling runners) and platforms (header tanks, air conditioning units etc.) shall be filled.
9.	Where possible material shall be installed under any ducting/piping systems/wiring/cables.
10.	No material shall be in contact with roofing products/underlay. A minimum gap of 25mm is required.

Amd 1
April '10

Amd 1
April '10

Amd 1
April '10

Amd 1
April '10

Amd 1
April '10

Copyright Sta

5 SEGMENTS AND BLANKET PRODUCTS

Installers shall provide written information in English on the product installed, e.g. bale label or product certificate in an accessible place such as a meter box, hot water cupboard or by an access hatch so that it is visible for future inspections. Amd 1
April '10

5.1 Ceilings – unlined

NOTE – These methods assume that the insulation will be installed from below before the ceiling lining is installed. Where appropriate, the installation can be also performed from the top in accordance with 5.2.

5.1.1 Segments and blankets (installation between ceiling joists/truss chords) Amd 1 April '10

The following steps shall be taken when installing insulation segments and blanket products in unlined ceilings.

Step	Action
1.	Cut the segments in accordance with the manufacturer's instructions to allow a good friction fit. Amd 1 April '10
2.	Gently push the cut segments into the ceiling space over the ceiling battens. There shall be no gaps around the outer edges of the segments and no folds in the segments themselves. Where segments are butted together there shall be no gaps between them (see figure 4).
3.	There shall be a total cover of the ceiling including at least 50% of the exterior wall top plates (except where obstructed by other framing members e.g. ceiling joists) ensuring minimal over flow into the eaves. Amd 1 April '10
4.	A minimum clear space of 25mm shall be maintained between the insulation product and either the roof underlay or the roofing (if exposed). Allow for the continued expansion of some insulation products after installation. If the insulation comes into contact with the roof underlay or the roofing before reaching the (middle of the) top plate, then maintaining a minimum of 25mm space shall take precedence over insulating to the middle of the top plate. Amd 1 April '10
5.	If necessary, apply strapping to support the segments temporarily until the lining is fitted. (See figure 5.) Amd 1 April '10
6.	A label from the product installed that includes the bale weight, design <i>R</i> -value, thickness (mm), date installed, product installed and installation company shall be left on site in a dry accessible and visible position, on ceiling rafter or truss. Amd 1 April '10
7.	At the end of the installation the installer shall check and repair any visible gaps, tucking in or folds, and use any offcuts to fill small gaps around doors, windows or double stud cavities.



Figure 4 – Segments in unlined ceiling

5.1.2 Blanket (installation between ceiling joists/truss chords)

Blankets of the correct width shall be used.

Step	Action
1.	Measure the blankets against the truss spacing and ensure the width is correct.
2.	The blanket shall be fitted slightly oversize to ensure a good friction fit.
3.	Gently pull the blankets into the ceiling space over the ceiling battens.
4.	There shall be no gaps around the outer edges of the blankets and no folds or tucking in, in the blankets. Where blankets are butted together there shall be no gaps between them.
5.	There shall be a total cover of the ceiling including at least 50% of the exterior wall top plates (except where obstructed by other framing members e.g. ceiling joists) ensuring minimal overflow into the eaves.
6.	Maintain a minimum clear space of 25mm height between the top of the insulation and the underside of the roof (and underlay). If the insulation comes into contact with the roof underlay or the roofing before reaching the (middle of the) top plate, then maintaining a minimum of 25mm space shall take precedence over insulating to the middle of the top plate.
7.	If necessary, apply strapping to support the blanket temporarily until the lining is fitted (see figure 5).
8.	A label from the product installed that includes the bale weight, design <i>R</i> -value, thickness (mm), date installed, product installed and installation company shall be left on site in a dry accessible and visible position, e.g. on ceiling access hatch.
9.	At the end of the installation the installer shall check and repair any visible gaps, tucking in or folds, and use any offcuts to fill small spaces such as around doors, windows or double stud cavities.



Figure 5 – Blanket in ceiling secured with strapping

5.2 Ceilings – lined

5.2.1 Segments

The following steps shall be taken to install insulation segments in lined ceilings. See figure 6.

Amd 1
April '10

Step	Action
1.	Any existing insulation shall be levelled and any damp insulation removed, see 3.4. Any displaced existing insulation shall be refitted prior to commencing work.
2.	Installation shall be started at the furthest points away from the ceiling access hatch.
3.	Poles should be used to push insulation into difficult to reach corners. Care shall be taken so that the insulation does not fold or tear.
4.	There shall be a total cover of the ceiling including at least 50% of the exterior wall top plates (except where obstructed by other framing members e.g. ceiling joists) ensuring minimal over flow into the eaves.
5.	A minimum clear space of 25mm shall be maintained between the insulation product and either the roof underlay or the roofing (if exposed). Allow for the continued expansion of some insulation products after installation. If the insulation comes into contact with the roof underlay or the roofing before reaching the (middle of the) top plate, then maintaining a minimum of 25mm space shall take precedence over insulating to the middle of the top plate.
6.	Trim around recessed luminaires and place auxiliary control equipment above the insulation. The gap between luminaires and edge of insulation is dependent on fitting type. See 3.5.
7.	A label from the product installed that includes the bale weight, design <i>R</i> -value, thickness (mm), date installed, product installed and installation company shall be left on site in a dry accessible and visible position, e.g. on ceiling access hatch.
8.	At the end of the installation the installer shall check and repair any visible gaps, tucking in or folds, and use any offcuts to fill small spaces such as around doors, windows or double stud cavities.

Amd 1
April '10

Amd 1
April '10

Amd 1
April '10

Amd 1
April '10

Amd 1
April '10

Amd 1
April '10

NOTE – Insulation should remain fully sealed in a plastic bag until the bag is completely within the roof cavity.

Amd 1
April '10

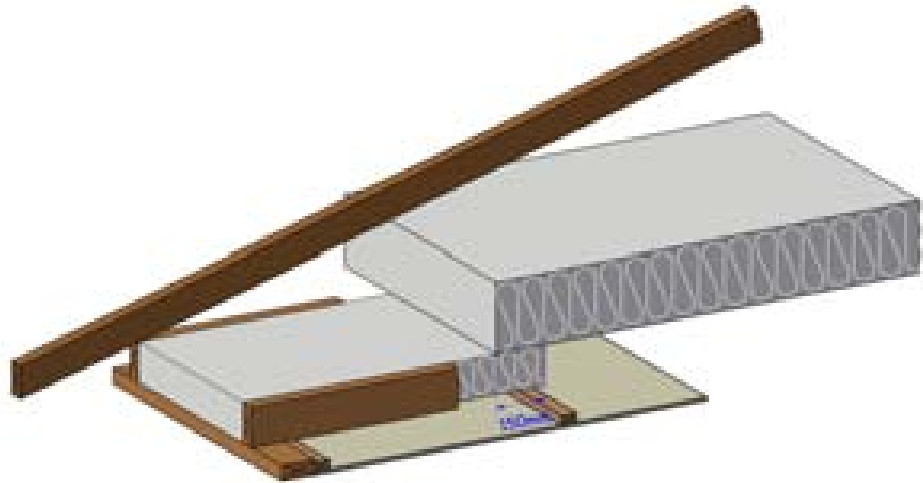

Figure 6 – Pitched roof – Segments installed in lined ceiling to top plate with continuous blanket overlaid by 150mm

5.2.2 Blanket

In lined ceilings blanket insulation can be installed over the timber structure perpendicular to joists/truss chords, rafters or trusses. Blanket insulation installed over the timber structure perpendicular to joists/truss chords, rafters, or trusses where there is no existing insulation shall be installed to prevent cross air flow ventilation occurring between insulation and ceiling lining. Where blanket insulation is installed between joist/truss cords see figure 7.

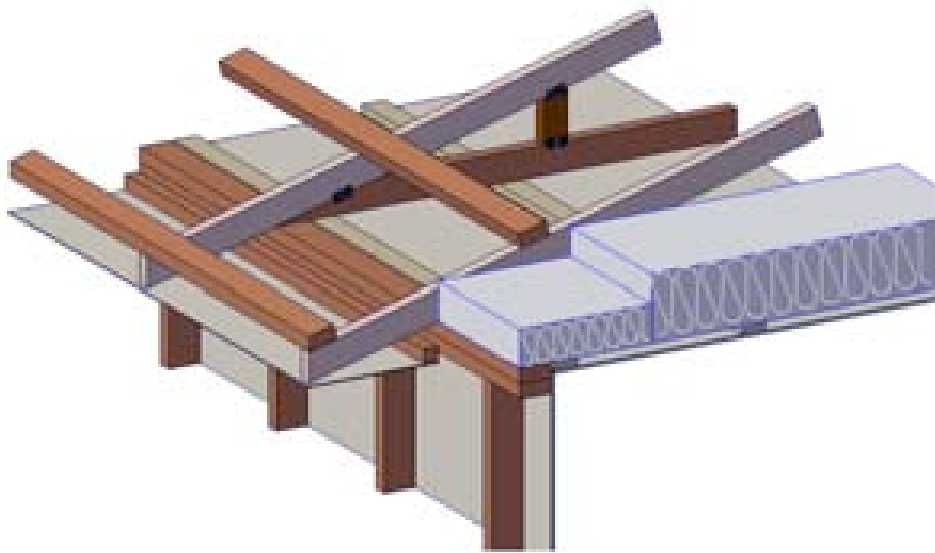

Figure 7 – Truss roof – Segment installed to top plate with full thickness blanket abutted to end of segment between truss

Step	Action	
1.	Any existing insulation shall be levelled and any damp insulation removed, see 3.4. Any displaced existing insulation shall be refitted prior to commencing work.	Amd 1 April '10
2.	Installation shall be started at the furthest points away from the ceiling access hatch. NOTE – Poles should be used to push blanket insulation into difficult to reach corners. Care should be taken that the insulation does not fold or tear.	Amd 1 April '10
3.	Allowance shall be made for a slight drooping of the blankets into the joist cavity to prevent ends of the blanket from creeping apart.	Amd 1 April '10
4.	Where roll lengths are butted together to form longer lengths, end connections shall be at the same height and square to one another. A supporting bridge (insulation offcuts) shall be used to achieve this.	
5.	The blanket shall be cut to fit to edges of the ceiling runner.	
6.	Along the perimeter of the ceiling open air pockets beside the joists/truss chords ends shall be blocked by: (a) Either tearing the blanket insulation over ceiling joists/truss chords 300mm back from the top plate (see figure 8) and the edge of the insulation and laid flat to the top plate of exterior, walls with the top plate covered to at least the middle; or (b) Blocking over top plate to the same height as the joists/truss chords using offcuts of insulation. NOTE – If using option (b) insulation shall have a recovered thickness of no more than the joist/truss chord depth and the blanket will be overlaid a minimum of 150mm onto blocking.	Amd 1 April '10
7.	All accessible areas of ceiling shall be insulated including under header tanks. Recessed areas and walls (including walls of porch areas) and ceilings of porch areas need not be covered. NOTE – Insulating under concrete header tanks is not recommended as these may crack.	Amd 1 April '10
8.	A minimum clear space of 25mm shall be maintained between the insulation product and either the roof underlay or the roofing (if exposed) to prevent condensation at the point of contact. Allow for the fact that some insulation products may continue to expand after installation. If the insulation comes into contact with the roof underlay or the roofing before reaching the top plate, then maintaining a minimum space of 25mm shall take precedence over insulating to the middle of the top plate.	Amd 1 April '10 Amd 1 April '10 Amd 1 April '10
9.	Passive (non mechanical) vents that open into the roof space shall be covered using a plastic sheet over the vent before fitting the insulation.	
10.	A label from the product installed that includes the bale weight, design R-value, thickness (mm), date installed, product installed and installation company shall be left on site in a dry accessible and visible position, e.g. roof rafter/truss.	
11.	At the end of the installation the installer shall check and repair any visible gaps, tucking in or folds, and use any offcuts to fill small spaces such as around doors, windows or double stud cavities.	Amd 1 April '10

NOTE – Insulation should remain fully sealed in a plastic bag until the bag is completely within the roof cavity.

Amd 1
April '10



Figure 8 – Blanket torn over the ceiling joist 300mm back from the top plate

5.2.3 Multiple layers

Where two layers of blankets are to be installed the first layer shall be installed in accordance with steps 1, 2, 4, 5 and 6 in 5.1.2. Fit the second layer, according to steps 2 – 10 in 5.2.2, perpendicular to the first layer, ensuring there are no gaps between the layers of insulation.

5.3 Walls – Unlined

5.3.1 Segments

Step	Action
1.	Cut the segments about 5mm greater than the space available against a firm straight surface.
2.	Gently push the segments into the wall space. There shall be no gaps around the outer edges of the segments and no folds or tucking in, in the segments. Where segments are butted together there shall be no gaps between them.
3.	Some products may need to be supported by either touching on all six faces or being fastened into place, without undue compression of the product. If so strapping may be installed horizontally at sufficient intervals to support the insulation until lining is installed. Strapping is only acceptable as a permanent means of support if installed at no greater than 300mm centres and where building wrap is not required to act as a moisture or air barrier.
4.	Where insulation does not fill the cavity, it shall be fitted flush with the external side of the framing.
5.	Continue cutting and fitting the segments, working along the walls until all of the exterior walls and any required interior wall spaces are filled from top to bottom plates. Wherever possible, segments should be laid behind electrical wiring or pipes. It is important that the insulation is not compressed. This can be achieved by cutting through part of the insulation and placing it around the pipes or wires.
6.	Use offcuts from the walls to fill small gaps around window and door framing and between double studs. However, segments shall not be tucked in at the edges of the framing in such a manner that decreases the thickness of the insulation (see figure 9). Installed segments must be of full thickness across the whole cavity.
7.	A label from the product installed that includes the bale weight, design <i>R</i> -value, thickness (mm), date installed, product installed and installation company shall be left on site in a dry accessible and visible position on ceiling rafter or truss.
8.	Inspect the finished job to ensure there are no gaps, tucking in, or folds (see figure 10).

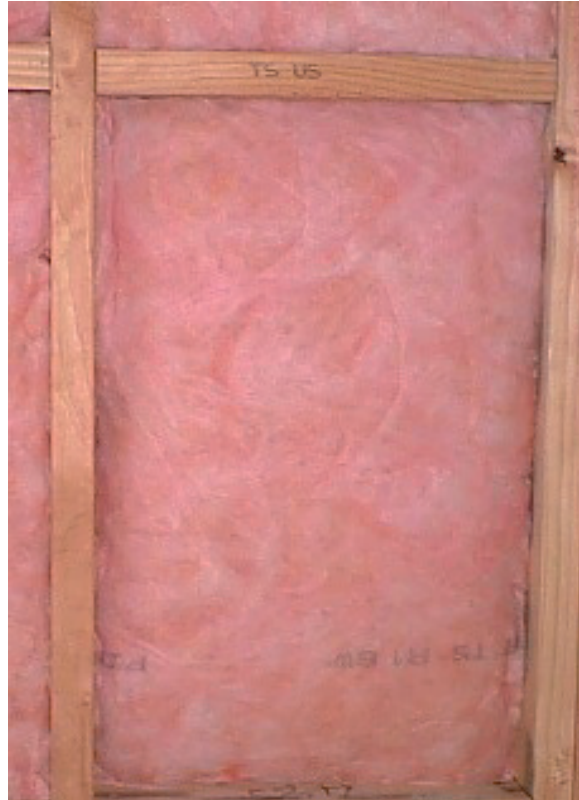

Figure 9 – Example of ‘tucking in’ showing undesirable compression of insulation at edges



Figure 10 – Segments correctly installed in new wall

5.3.2 Blanket – framed walls

Blanket intended for installation in walls and of the correct width shall be used.

Step	Action
1.	Measure the blankets against the wall framing to find the best fit. The product shall be fitted slightly oversize to ensure a good friction fit.
2.	Depending on manufacturer’s instructions, tear or cut the blankets about 5mm greater than the space available against a firm straight surface (see figure 11).
3.	Gently push the blanket pieces into the wall space. There shall be no gaps around the outer edges and no folds or tucking in, in the blanket pieces. Where blanket pieces are butted together there shall be no gaps between them.
4.	Some products may need to be supported by either touching on all six faces or being fastened into place, without undue compression of the product, for instance, by stapling (see figure 12). Strapping may be installed horizontally at sufficient intervals to support the insulation until lining is installed. Strapping is only acceptable as a permanent means of support on unlined walls, if installed at no greater than 300mm centres and where building wrap is not required to act as a moisture or air barrier.
5.	Where insulation does not fill the cavity, it shall be fitted flush with the external side of the framing.
6.	Continue cutting and fitting the blanket, working along the walls until the entire exterior wall and any required interior wall spaces are filled from top to bottom plates.
7.	Wherever possible, blanket insulation shall be laid behind electrical wiring or pipes. It is important that the insulation is not compressed. This can be achieved by cutting through part of the insulation and placing it around the pipes or wires.
8.	Use offcuts from the walls to fill small gaps around window and door framing and between double studs.
9.	A label from the product installed that includes the bale weight, design <i>R</i> -value, thickness (mm), date installed, product installed and installation company shall be left on site in a dry accessible and visible position on ceiling rafter or truss.
10.	Inspect the finished job to ensure there are no gaps, tucking in, or folds (see figure 13).



Figure 11 – Tearing blanket to fit

Copyright Standards New Zealand. This PDF is provided to
 EECA under copyright licence number 000787.
 Amd 1 April '10
 Amd 1 April '10
 Amd 1 April '10
 Amd 1 April '10
 Amd 1 April '10
 Amd 1 April '10



Figure 12 – Stapling blanket



Figure 13 – Completed blanket installation in framed walls

Amd 1
April '10

5.3.3 Segments – masonry walls

Segments specifically intended for use between strapping over masonry walls shall be installed in accordance with 5.3.3 (steps 1 – 5) and 5.3.4 (steps 1 – 5) respectively.

Step	Action
1.	See manufacturer's instructions regarding preparation of the wall prior to installation.
2.	Friction fit segments between vertical strapping members against masonry wall.
3.	It may be necessary to staple the top of the insulation temporarily until the wall linings are in place.
4.	There shall be no gaps, tucking in, or folds.
5.	Inspect the finished job to ensure there are no gaps, tucking in, or folds.

Amd 1
April '10

5.3.4 Blankets – masonry walls

Blanket specifically intended for use in masonry walls, and at the correct width, shall be used.

Step	Action
1.	Install the blanket as a continuous roll in between battens. The blanket shall be secured at the top of the wall and draped down to the bottom plate. The blanket shall be the same thickness as the batten.
2.	Blanket insulation shall be cut to size where necessary to fit between pipe work or cable in the wall cavity and the wall lining.
3.	Blanket insulation shall have no joins and should be continuous inside the framed cavity.
4.	For bulkheads, the blanket shall be cut and staple fixed on all edges so as to minimise the formation of thermal bridging. No joins are allowed.
5.	Inspect the finished job to ensure there are no gaps, tucking in, or folds.

5.4 Floors – new and existing

5.4.1 Blanket

Ensure that the blanket insulation is designed to be installed under the floor between the joists. The product shall be fitted slightly oversize to ensure a good friction fit. If the insulation is designed to be fitted with one surface uppermost, check that this surface is clearly identified.

If there is existing insulation in place, in poor condition, this shall be removed before the new insulation is fitted.

Amd 1
April '10

Amd 1
April '10

Step	Action
1.	Distribute the bags or rolls of insulation to the areas to be covered. Leave them bagged.
2.	Split or open the bags and pull out the product. Run the product in a continuous length between the floor joists and over the main bearers. Ensure that the designated outer layer is towards the ground.
3.	Gently push the insulation up to the bottom of the floorboards, while still retaining its loft. Ensure there is no tucking in or folds in the blanket pieces and there are no gaps where the rolls or pieces are butted together.
4.	Stapling should be as per the manufacturer's instructions, ensuring the insulation material shall remain in full contact with the underside of the floor. (See figure 14.) Do not staple directly to the underside of the floor – this will compress the product and reduce its effectiveness.
5.	Where the joist spacings vary, measure the gap by holding the product up to the joists and simply rip across the roll to size. Alternatively the roll can be cut with a straight edge to facilitate stapling. Push into place as above, staple, and repeat until the joist row is complete.
6.	On completion, remove all plastic bags and leftover product from the underfloor space. Ensure that there are no gaps, tucking in, or folds. Check that all electrical and TV cables have not been damaged. Cut a label from the blanket installed and staple alongside the access where it can be easily found during subsequent inspection.



Figure 14 – Installing underfloor blanket

6 RIGID AND SEMI-RIGID SHEETS

Rigid sheet insulation can be installed under and/or between floor joists, within wall framing, over or between ceiling joists/rafters of timber buildings.

6.1 Fixings

When installing rigid sheet insulation under timber floors, non-corrosive fixings shall be used to support panels.

C6.1

When cutting polystyrene sheet use a sharp knife to achieve a smooth edge.

Any other cutting method should be as recommended by the manufacturer.

For timber floors, walls, and ceilings, a number of manufacturers have added concertina cuts to the edges of sheets to ensure a snug fit between framing.

These concertina-cut edges can also be used for trimming sheets to size.

6.2 Pipes and plumbing

To accommodate obstacles such as protruding pipes and plumbing, use a sharp knife to cut the panel and notch around the difficult areas. A gap of approximately 100mm shall be maintained between sheets and the plumbing pipe work and fittings in case of water leaks. This gap will ensure there is adequate service access to repair damaged pipes and fittings.

6.3 Electrical cables

When installing polystyrene insulation in areas around PVC-coated cables ensure there is no contact between the polystyrene and the PVC.

Methods of avoiding contact include:

- (a) Installing cables in a conduit;
- (b) Using polyethylene or polypropylene tape between the PVC and polystyrene;
- (c) Using cables with a non-migratory PVC sheath; or
- (d) Separating electrical cables from polystyrene insulation, with products specified by the insulation manufacturer.

6.4 Ceiling – unlined and lined

When installing rigid sheet insulation in ceilings the following steps shall be taken.

Step	Action
1.	Any existing damp insulation shall be removed before installing more insulation.
2.	If insulation product is being installed between the timbers it shall be cut to a width at least 2mm greater than the distance between the framing timbers and placed hard against the internal lining.
3.	If insulation is installed over the framing timber, then any open air pockets beside the joists/truss chords ends along the perimeter of the ceiling shall be blocked by blocking over top plate to the same height as the joists/truss chords using offcuts of insulation.
4.	All edges and join lines shall be filled after installation with flexible extruded filler.
5.	Installation shall cover all of the ceiling area between the outside wall plate lines.
6.	Spaces below ceiling runners, header tank platforms and any ducting shall be insulated.
7.	At the end of the installation check for any visible gaps. Fill any gaps found and fit a segment of insulation equivalent to the design <i>R</i> -value to the access cover space.

Amd 1
April '10

Amd 1
April '10

6.5 Walls – unlined

When installing rigid sheet insulation in walls the following steps shall be taken.

Step	Action
1.	Any existing damp insulation shall be removed before installing more insulation, see 3.4.
2.	If insulation product is being installed between the framing timbers it shall be cut to a width at least 2mm greater than the distance between the framing timbers.
3.	Where insulation does not fill the wall cavity, it shall be fitted flush with the external side of the framing.
4.	All edges and join lines shall be filled after installation with a flexible extruded filler as the insulation product is installed.
5.	Installation shall cover all of the wall area between the top and bottom wall plate lines.
6.	Place the cut segments into the wall cavity space between the framing timber. There shall be no gaps between any segment and the framing timber or adjoining segments.
7.	Insulation product shall be cut around or between pipes or wires, separated from PVC-coated cables (see 6.3).
8.	At the end of the installation check and repair any visible gaps by using the insulation offcuts or foam to fill small gaps around doors, windows, or double stud cavities.

Amd 1
April '10

Amd 1
April '10

Amd 1
April '10

6.6 Underfloor – new and existing

NOTE – This installation method assumes no existing underfloor insulation is present.

6.6.1 Rigid floor installation

Step	Action
1.	If insulation product is being installed between the timber it shall be cut to a width at least 2mm greater than the distance between the framing timber and pushed in hard against flooring. NOTE – With some products it can be easier to position one side of the rigid sheet in the corner between the floor and the floor joist and then push up the other side while squeezing the concertina edge. That will ensure a very good friction fit of the rigid sheet.
2.	Installation shall cover all of the floor area.
3.	Cut insulation around any plumbing protruding through the floor (see 6.2).
4.	At the end of the installation check and repair any visible gaps, and use offcuts of insulation or foam to fill small gaps except around plumbing.

See figure 15 for an example of installing rigid floor insulation.



Figure 15 – Installation of underfloor rigid floor insulation

6.6.2 Semi-rigid floor installation

6.6.2.1 Semi-rigid sheets that are friction fitted only

These products shall be installed only when the building is closed in (weather tight) and the construction products have achieved the required maximum permitted moisture content or less.

Semi-rigid sheets are manufactured and designed for friction fitting between the joists.

Always check the manufacturer's specification for the minimum or maximum sizes per sheet. This ensures that the friction fit is adequate and the sheet does not fall out of the space between the joists.

Installation widths will be on the bale label as a requirement of AS/NZS 4859.1.

For semi-rigid sheets that are installed by friction fitting the insulation between the floor joists, the following steps shall be taken.

Step	Action
1.	Hold the long edge of the sheet against the internal corner formed by the joist and the floor junction.
2.	The body of the sheet shall be pressed hard up against the underside of the floor, leaving no gap between the insulation material and underside of the flooring (see figure 16).
3.	Fold the trailing edge to make a sharp crease ensuring that the friction fit is tight and the sheet is secure.
4.	Check the depth of folding edge is correct as specified by the manufacturer (generally 25 – 75mm).
5.	The ends of each sheet shall be snugly fitted and there must be no gaps between subsequently installed strips.
6.	When a single joist becomes a double joist thickness, make a right angle cut and fit the semi-rigid sheet so that it fits snugly.
7.	It is important to either cover the bottom plates of the exterior walls or butt an end of the semi-rigid sheet to the plate if that plate is below the level of the floor.
8.	When sheets are installed in brick veneer buildings or a building with a ventilated cavity in the walls, fit the semi-rigid sheet to the outer edge of the bottom plate. Do not block the ventilated cavity as this will minimise air circulation and result in excessive moisture in the walls.
9.	A maximum of 100mm shall be maintained between the semi-rigid sheets and the plumbing pipe work and fittings in case of water leaks. This gap will ensure there is adequate access for a serviceman repairing damaged pipes and fittings.
10.	A quality check shall be conducted upon completion to ensure that folds are correct and all the sheets are fitted properly.

Amd 1
April '10



Figure 16 – Fitting semi-rigid sheets

Copyright Standards

7 HOT WATER CYLINDER WRAPS

Amd 1
April '10

A hot water cylinder wrap is used to insulate an electric hot water cylinder (electric storage water heater), to reduce the standing heat losses from the cylinder (see figure 17 for an illustration of a completed wrap).

Hot water cylinder wraps shall not be installed on gas storage water heaters.

Installation of a hot water cylinder wrap shall comply with the following steps.

Step	Action
1.	Ensure that the cylinder is electric. Follow all of the wrap manufacturer's instructions.
2.	Inspect the cylinder and ensure that there are no leaks, and electrical connections are in good condition. Ensure that the element /thermostat cover is in place. If a problem is found report it to the owner/agent and discontinue installation.
3.	Turn off the power to the cylinder either at the fuse box or at the isolating switch. Take care not to damage pipes.
4.	Remove any earthquake strapping and retain pieces.
5.	Measure the height and circumference of the cylinder.
6.	Remove the cylinder wrap from the bag and lay it out with the exterior facing upwards and mark the dimensions out on the foil.
7.	Using the straight edge, cut through the exterior and insulation with the knife. NOTE – It will be easier if it is cut on a timber surface.
8.	Find the side with the larger gap between the cylinder and the cupboard to insert the wrap, so the wrap is less likely to jam. A cord can be tied to a bottom corner of the wrap to assist with pulling the wrap around the cylinder.
9.	Pull the join together and partially tape or tag the join checking that it is near where the thermostat and element control box are, so that these can be accessed by other tradespersons.
10.	Gather the top of the wrap tightly around the pipe over the pipe lagging ensuring there are no air gaps and tie tightly with the tie provided. If a lid is provided or required it shall be installed at this stage.
11.	Seal the join down the wrap using the fastening products provided ensuring a snug fit and repairing any minor tears from installing.
12.	Reinstall any earthquake strapping previously removed.
13.	A bale label or product certificate containing the following information shall be fixed to the wrap so that it is visible for future inspections: (a) Product name; (b) Name and address of manufacturer; (c) Safety instructions; (d) Nominal net weight of contents (kg); (e) Nominal stabilised thickness; and (f) R-value.
14.	Inspect the job to ensure that the cylinder is fully enclosed and that the air gap around the top and sides of the cylinder is properly sealed.
15.	Turn the power to the cylinder back on.

Amd 1
April '10

Amd 1
April '10



NOTE – The Compliance Documents for NZBC Clause G12 requires seismic restraint straps to be fitted to all hot water cylinders. A minimum of two straps are required for cylinders up to 200 litres, and three straps for cylinders greater than 200 litres.

Figure 17 – Insulated hot water cylinder

8 ON-GROUND VAPOUR BARRIERS

Vapour barriers installed on the ground under suspended timber floors shall cover the accessible subfloor area, and:

- (a) Have a vapour flow resistance of no less than 50 MN s/g, and a thickness of no less than 0.25mm; and
- (b) Be of virgin polythene film, or any other product that satisfies this requirement.

NOTE – A ground vapour barrier should only be installed where there is an enclosed perimeter wall foundation.

C8

The need for vapour barriers (see figure 18) can arise from a variety of situations, for example:

- (a) *Under-floor ventilation is inadequate; and/or*
- (b) *Condensation is appearing in the roof space.*

Roof space condensation (particularly during winter) can be a significant problem in older buildings and is most often caused by the migration of moist air from the subfloor space to the roof space by the framing and drainage cavities. Buildings most commonly affected are those with masonry veneer cavities and suspended timber floors. The most effective remedy for this problem is to install a vapour barrier to the subfloor area to limit moisture emission from the subfloor space. For further information refer to the BRANZ Study Report SR 7 (1988).

Amd 1
April '10

Step	Action
1.	Prepare the ground to be covered by the vapour barrier by removing any product that is likely to puncture the membrane and rake where necessary to create a smooth, even surface.
2.	Prepare a sheet of polythene the length of the house and wide enough to be cut around and extend past the outermost edge of the first row of piles.
3.	Lay the polythene up to the inside edge of the foundation wall on one side and at each end, and across to and cut around the first row of piles. Repeat the process until the entire subfloor area has been covered.
4.	The polythene shall be: <ul style="list-style-type: none"> (a) Overlapped by a minimum of 150mm; (b) Pinned or weighted to secure the sheets in place at no more than 1 m spacing; and (c) On sloping sites, lapped to prevent ground water from running over the sheets, see figure 19.
5.	The polyethylene shall be cut from the edge of each run to the piles, to allow the sheet to be positioned with the slit around the pile.
6.	Small cuts shall be made in the polyethylene around the piles to allow the sheet to be taped to the piles.
7.	All the joins from the piles to the sheet edge and the joins between the sheets shall be taped.
8.	All joins where the piles protrude through the polyethylene shall be taped. NOTE – Taping in steps 7 and 8 is required for durability but not for moisture seal.

Amd 1
April '10

Amd 1
April '10

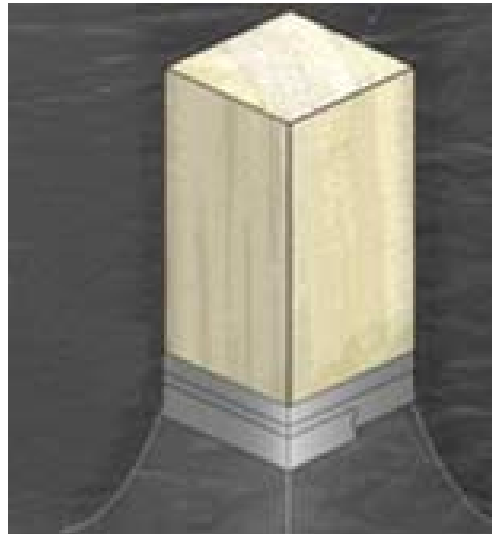

Figure 18 – Installing an on-ground vapour barrier

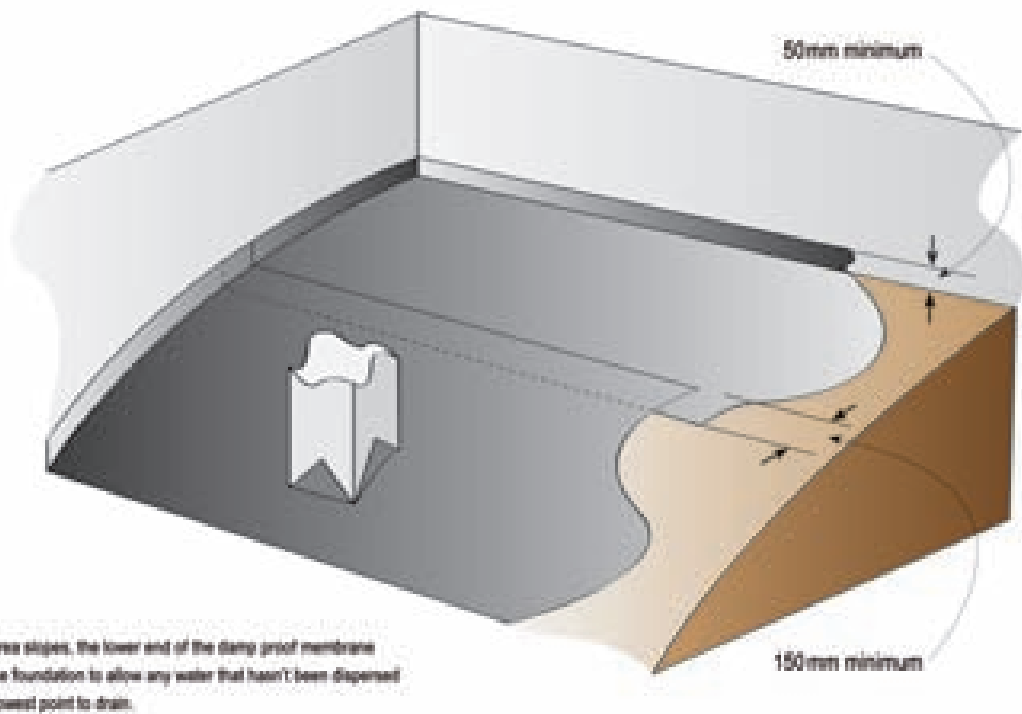

Figure 19 – On-ground vapour barrier

9 PIPE INSULATION

Pipe insulation is designed to insulate the hot water supply pipes that are attached to the water cylinder. In new homes, NZS 4305 requires insulation of the vent pipe to 300mm above the standing water level and the first 2m of the distribution pipe.

Amd 1
April '10

In existing homes, the first 1m of all hot water pipes shall be insulated.

Pipe insulation shall be installed prior to cylinder wrap where possible.

NOTE – See 3.18 for information on insulating cold and hot water pipes in ceiling spaces.

Amd 1
April '10

9.1 Fitting the insulation

Amd 1
April '10

9.1.1 Hessian backed wool

Step	Action
1.	Identify the hot water supply pipe which comes out from the top of the cylinder.
2.	Secure the insulation (with hessian outermost) using tape or a cable tie around the hot water supply pipe, starting where it comes out from the cylinder. NOTE – This prevents the insulation from slipping as it is wound around the pipe.
3.	Wind the insulation firmly up the pipe with a 50% overlap ensuring the pipe is fully covered.
4.	Close off the end of the insulation with tape or a cable tie.
5.	Secure cable ties or tape firmly around the insulation at 200mm intervals.

Amd 1
April '10

Amd 1
April '10

Amd 1
April '10

Amd 1
April '10

9.1.2 Pre-formed pipe insulation

Amd 1
April '10

Step	Action
1.	Identify the hot water supply pipe which comes out from the top of the cylinder.
2.	Cut a length of foam insulation to suit the pipework.
3.	Slit the foam insulation lengthwise.
4.	Fit the foam around the hot water supply pipe (with slit to underside if possible).
5.	Pull the slit closed to fully enclose the pipe, and tape lengthwise as well, taking care not to compress the insulation.
6.	Apply additional tape around the foam insulation at 120mm intervals ensuring there are no gaps, tucking in, or folds in the foam insulation.

Amd 1
April '10

Amd 1
April '10

Amd 1
April '10

APPENDIX B – HEALTH AND SAFETY

(Informative)

Reproduced with permission from the Energy Efficiency and Conservation Authority.

B1 INTRODUCTION

The health and safety of installers during home insulation installations is of paramount importance; however it is equally important to protect the health and safety of all others who may be adversely affected by the installations.

This Appendix provides practical health and safety guidance for installing energy saving products, including effective hazard management and incident reporting systems to ensure the safety of installers, householders, visitors and others during new and retrofit insulation installations.

This guidance should be referenced by home insulation project managers, trainers, installation teams and can easily be used by the DIY public wishing to make insulation improvements to their own homes.

The Health and Safety in Employment (HSE) Act 1992 discussed in this guidance applies to employers, employees and the self employed, but not DIY installers. Without limitation the majority of the 'known' hazards have been identified in this guidance to promote safety across industry and the home. Each installation is unique and will require an individual hazard assessment to determine the specific controls necessary to ensure the continued safety of those concerned.

B2 INSTALLATIONS DISCUSSED IN THIS APPENDIX

The particular insulation installations covered by this appendix are outlined as follows:

B2.1 Ceiling insulation

Ceiling insulation installation if installed correctly will prevent significant heat losses and save money on energy use. The hazards in each work area are seldom the same due in part to the design of the roof, other installations (such as TV aerials) and the external environment. Cuts, heat exhaustion, dust inhalation and eye injuries need to be considered together with the obvious hazard of crouching around a fragile ceiling structure which is relatively easy to fall through.

B2.2 Floor insulation

Floor insulation installation involves more interaction between the installer and the structure of the house and services such as electricity, gas, water, sewage, telephones, etc. The work area is often cramped and includes hazards such as old building products, glass, nails, moulds and stagnant water. The practice of stapling insulation to the underfloor structure introduces the significant hazard of electrocution, which this guide covers in detail, complete with the necessary control measures to manage this hazard.

Amd 1
April '10

B2.3 Hot water cylinder wraps

The hazards associated with installing hot water cylinder wraps are few, however with foil-backed cylinder wraps the addition of an electrical conducting surface (such as foil) requires careful installation to prevent it inadvertently becoming electrically 'live'.

B3 HEALTH AND SAFETY OBLIGATIONS

The health and safety obligations discussed in this guidance are not a legal substitute for compliance with the HSE Act. Employers, Employees, Principals, Persons in Control of a Workplace and Suppliers etc., have specific duties that are not covered by this guidance. This appendix covers some of the broad obligations arising from the HSE Act and should only be used as a guide.

B3.1 Employers – Service providers / supervisors

Employers have to ensure the health and safety of employees and those who may be adversely affected by their work. If you are an employer, then you will have a general duty to take 'all practicable steps' (section 6 HSE Act) to ensure the safety of employees and others at work.

B3.1.1 General

In general, principals and persons in control of a workplace are required to:

- (a) Provide contractors and employees with readily available appropriate notification of significant hazards on their sites, prior to the commencement of work at that site, including:
 - (i) The nature and location of significant hazard (such as electrical hazards and reflective pliable membranes installed under the floor)
 - (ii) The preferred methods and procedures to control hazard exposure
 - (iii) Possible effects of hazard exposure
 and ensuring accurate information is documented, updated, and maintained as required;
- (b) Implementing appropriate control measures; by taking all practicable steps to eliminate, isolate, or minimise exposure in the place of work and near the place of work and under their control (for example, by ensuring appropriate isolation of electrical circuits). It may be appropriate in some circumstances to specify these standards in an agreement or contract.

In general, employers are required to:

- (c) Provide and maintain a safe working environment;
- (d) Provide and maintain appropriate personal protective equipment (PPE);
- (e) Provide and maintain a suitable first aid kit;
- (f) Provide and maintain facilities for the safety and health of employees at work;
- (g) Ensure that machinery and equipment in the place of work is designed, made, set up, and maintained to be safe for employees;
- (h) Ensure that employees are not exposed to significant hazards in the course of their work; and
- (i) Develop procedures for dealing with emergencies that may arise while employees are at work.

B3.1.2 Information

Before an employee begins work, as an employer you must inform them of:

- (a) Emergency Procedures;
- (b) Hazards the employee may be exposed to while at work, or which the employee may create while at work which could harm themselves or other people;
- (c) How to reduce the consequences and likelihood that these hazards become a source of harm to themselves and others; and
- (d) The location of safety equipment.

B3.1.3 Training

Employers must ensure employees are either sufficiently trained and experienced to do their work safely or are supervised by a trained and experienced person. In addition, the employee must be adequately trained in safety precautions particular to installations, safe use of equipment in the place of work and the appropriate use, storage and maintenance of safety equipment and clothing.

B 3.2 Employees – installers

If you are an employee, the HSE Act gives you responsibility for your own safety and health while at work. You must also ensure that your actions or inactions do not result in harm to anyone else. In the event that an accident has occurred in the workplace, after you have provided the necessary support to the injured person you must not disturb the accident scene until either:

- Your employer (Supervisor in most cases) has said you can carry on as it is not a 'Serious Harm' injury (HSE Act); or
- Your employer (Supervisor in most cases) has said that a Department of Labour Inspector has given approval for the accident scene to be disturbed.

B3.3 Accident notification

The HSE Act defines 'accident' as an event that –

- (a) Causes any person to be harmed; or
- (b) In different circumstances, might have caused any person to be harmed.

This means that 'accident' includes both near-misses and where harm has actually occurred. Employers are required to keep a register of all 'accidents'.

B3.4 Personal protective equipment

Personal Protective Equipment is to be provided and maintained by the employer. Following appropriate training in the use and storage of the equipment, the employee must keep it in good working condition. For installing Ceiling and Floor insulation the following protective clothing is suggested:

Ceiling installations



- Air purifying respirators
- Nylon overalls
- Gloves
- Kneepads
- Light shoes

Floor installations



- Air purifying respirators (not shown)
- Polycotton overalls
- Gloves
- Kneepads
- Shoes or boots

B4 HAZARD MANAGEMENT

B4.1 Hazards as they relate to serious harm

A hazard is in its most simplistic sense is ‘anything’ that is an actual or potential source of harm. Employers have a duty to identify hazards in the place of work (previously existing, new and potential) and regularly review them to determine whether they are ‘significant hazards’ (HSE Act) and require further action.

‘Significant hazard’ means a hazard that is an actual or potential cause or source of –

- Serious harm (HSE Act); or
- Harm (being more than trivial) the severity of whose effects on any person depend on the extent or frequency of the person’s exposure to the hazard; or
- Harm that does not usually occur, or usually is not easily detectable until a significant time after exposure to the hazard.

B4.2 Where a hazard is significant

Where a hazard has been determined as being a ‘significant hazard’ the employer must take ‘all practicable steps’ (HSE Act) to:

- **Eliminate** the hazard (1st priority) **Isolate** the hazard (2nd priority), or, if eliminating the hazard or isolating are impracticable, the employer must **Minimise** the impact of the hazard to its employees; and **Monitor** employees’ exposure to the hazard.

B5 SITE SPECIFIC HAZARD ASSESSMENT

This appendix contains many of the general and installation specific hazards associated with residential insulation installations. In section B4.1 we discussed the obligation the employer is under to assess hazards that **Previously Exist**, **New** or those with **Potential**.

To ensure the continued safety of employees, contractors, and others, it is imperative that a site specific hazard assessment is conducted before the installation of any type of insulation product. The principal or persons in control of a workplace should provide contractors and employees with notification of significant hazards on their sites and preferred methods to control those hazards. The employer should use their own hazard identification system to record their findings and convey the results of those assessments, complete with the precautions necessary to control those hazards, to the employees (installers) at the site.

Amd 1
April '10

Amd 1
April '10

The site specific hazard assessment should be accompanied by the following additional information:

- (a) Site address;
- (b) Supervisor in charge;
- (c) First Aid trained personnel;
- (d) Emergency procedures; and
- (e) Accident reporting procedures.

Completing the site specific hazard assessment prior to the installation of insulation products will act as a useful focus during the site safety briefing (usually conducted by the Supervisor) and provide an opportunity for employees who are unsure of the specific precautions to reference the appendix during the installation.

B6 GENERAL SAFETY PRECAUTIONS

There are a number of safety precautions that are common to the three insulation installations covered by this guidance. The site generic hazards and their associated precautions are covered in this section of the appendix, while the installation specific hazards are covered under separate headings later in this appendix.

B6.1 Access

Hazard description – Each site is different and gaining access to the building may pose its own problems. Once in the building the installer should pay particular attention to the routes to the installation's internal stairs, roof hatches, and underfloor entry. Damaged or poorly-lit access may lead to injuries resulting from falls.

Precautions – Survey the site first and plan how to load/unload products. Where there are manual handling (load handling) hazards present, reduce the risk by using mechanical aids or work in pairs to stabilise loads. Check stair treads for damage and grip. If there are damaged stairs consider whether it is safe to carry out the work until the stairs have been repaired. Ensure walkways are clear of obstructions and that handrails, where present, are in good condition. In poorly-lit areas employers must ensure that their employees have enough portable lights to carry out the installation in safety.

Amd 1
April '10

B6.2 Respiratory irritants

Hazard description – Dusts in various forms are considered to be respiratory irritants. People who experience asthma or who have any other respiratory illness will be particularly affected by exposure to dusts. The results may include asthma attacks and a build-up of fluid in the lungs leading to breathing difficulties. This hazard relates to installers, occupants and visitors to the site.

Precautions – During your site survey explain to the occupant that the nature of the work may create atmospheric dust. Enquire if this is going to be of particular concern to them, taking action to reduce the atmospheric dust further. This can include simple measures like closing all doors and windows to reduce draughts. Keep occupants as far away from the installation as possible. If health reasons dictate, suggest to the occupant that they may like to leave the building during very disruptive installations. Where this is not possible use decorator's masking tape to isolate areas from the occupants (use only non-marking masking tape to avoid damage).

B6.3 Equipment

Hazard description – Poor storage and maintenance of equipment may lead to avoidable accidents. Some of the most common injuries are caused by using equipment that is known to be damaged but has not been replaced because of tight deadlines.

Precautions – Check equipment before you bring it onto the site. Ensure the check includes ladders, electrical goods, personal protective equipment, first aid kits and mobile phones. All electrical tools should be plugged into a Residual Current Device (RCD) which detects anomalies in electrical supply, isolating the power before harm occurs. Problems identified with any equipment should be recorded on the site specific hazard assessment as New or Potential hazards that need to be addressed.

B6.4 Working alone

Hazard description – There may be times when you are the only qualified person on site. This may result from a colleague needing to get more products or simply that you may be in a part of the building which only you are accessing.

Precautions – The first and most important step is to make sure your colleagues are aware of your work schedule, including your location. In addition to the convenience factor, having a mobile phone is a good way of requesting assistance. However, it is equally important to remember that there may be some areas that do not have reception, so this should be checked first. Relying on the occupants is not recommended, as it is not likely that they will have the skills and knowledge required to assist you in an emergency. If the task requires two people do not work alone.

B6.5 Violence

Hazard description – Although rare, violence can become a significant safety concern resulting in additional stress and sometimes physical attacks.

Precautions – Following the Site Access guidelines and paying particular attention to your behaviour will usually reduce the chances of any conflict. The key to reducing the incidence of violence is good communication. Briefing the occupant is important and the installer should ask the occupant if they have any specific requirements or customs which they would like to be upheld. Should reasonable negotiations fail, the installer

must inform the occupant of their company's complaints procedure, make the site safe and leave until the situation can be resolved. In extreme cases, a call should be made to the police for assistance.

B7 CEILING INSULATION SAFETY PRECAUTIONS

B7.1 Falls from height

Hazard description – There are two possibilities to fall from a height while carrying out the ceiling insulation installation. The first, and easiest to avoid, is falling from a step ladder; the second is falling between the joists (or other supporting structure) through a plasterboard ceiling.

Precautions – Using a lockable step ladder, check it for damage prior to use and ensure it is firmly positioned on a level base. The ladder should be adjustable to enable the top rung to be positioned as close to the ceiling hatch as possible. On accessing the ceiling cavity, the priority is to set up adequate lighting for the whole area, allowing for easy identification of the joists. Walk only on the joists.

B7.2 Heat exhaustion

Hazard description – Working in the ceiling cavity can be hot, tiring work. During ceiling installations the installers are likely to lose more body fluids through perspiration than during any of the other installations. Heat exhaustion is a fairly quick process and can result in a person becoming ill or unconscious.

Precautions – Carry out installation work in the ceiling at the beginning or end of the day, avoiding the midday heat. Take plenty of fluids before, during and after the ceiling installation as heat exhaustion can still occur after exposure to prolonged periods of heat. If it is uncomfortably hot, ensure there are regular breaks to cool down and take on extra fluids. Specify the use of respirators that are fitted with exhaust valves to reduce heat build-up.

B7.3 Dust inhalation and skin irritation

Hazard description – Dusts are both respiratory and skin irritants and exposure to them is likely when carrying out ceiling insulation installations. Sources of exposure can be both new and old product so it is important to cover as much skin as possible and protect those in the vicinity from the dusts.

Precautions – Disturbing as little product as possible will reduce exposure to dusts. As a minimum, wear nylon overalls and a suitable respirator with an exhaust valve fitted.

B7.4 Electricity

Hazard description – The primary risk from an electric shock is serious injury or death. The second is damage to electrical supplies to the residence. Work in the ceiling does not include staples or other devices that can puncture the outer sheath of a wire; however the wiring may be old or damaged. Moving cables during the installation of ceiling insulation increases the likelihood of damaging the sheath and exposing the installer to 'live' wires.

Precautions – Search for wires with damaged sheaths, treating those identified as 'live' and dangerous. **Stop** the installation until a registered electrician has made the wiring safe.

Amd 1
April '10

Amd 1
April '10

B7.5 Sharp objects

Hazard description – By the very nature of construction work there will be times when nails will be left protruding, which if struck can cause puncture wounds or cuts. Other sharp objects can include TV aerials, pipework, wood, etc. and should be included in the hazard identification.

Precautions – The most effective method to deal with a single nail is to flatten it using a hammer, taking care not to strike any cables. If this is not possible because of the number of nails (tile hangers) and other protruding objects, wrap them in padding (eg. TV aerials) where possible or recommend the installer wear a hat (preferably a bump cap – baseball type cap with a rigid plastic liner) to protect themselves. At all times shoes should be worn when working in the ceiling.

B7.6 Wasps and bees

Hazard description – Pests such as wasps and bees like to nest in ceiling cavities as they provide protection from wind, rain and temperature fluctuations. Stings can be an irritant to most, but to those who are allergic to them, they can cause anaphylactic shock. In some cases those experiencing anaphylactic shock may require urgent hospital treatment.

Precautions – Walk around the house to identify any nests under the gutters or eaves. Then, using a torch, the first person to gain access to the loft should do so making as little noise or vibration as possible. Run the torch down the inside of the eaves, the apex of the roof and the lower edges to identify any nests. If nests are identified, work should not commence until they have been removed by a pest controller.

B8 FLOOR INSULATION SAFETY PRECAUTIONS

B8.1 Electricity

Reflective pliable membranes pose a number of electrical safety risks for installers, servicemen and house occupants should they come into contact with these membranes at any stage during life of the house.

Hazard description – The most significant hazard to be managed during underfloor installations is exposure to electricity. This could be in the form of exposed wires or through accidentally puncturing through the sheath of a cable.

Discussion – Installers must make a decision at each site whether to install with the power 'ON' or 'OFF'. Before this decision is made, the hierarchy of controls defined in the HSE Act must constantly be reviewed and processes or products substituted to ensure all of the available practicable steps to provide for a safe installation have been taken.

In priority order consideration must be given to:

- (a) Eliminating hazards – Use non-conductive insulation products and other forms of fixing such as adhesive or plastic staples. *Where this is not practicable:*
- (b) Isolating people from hazards – Place physical guards over cables or use 'distance' as a barrier by stapling a predetermined measurement away from any wires/cables. *Where this is not practicable:*
- (c) Minimising the hazards – Installer training is crucial, however it is only deemed a 'minimising' control as it relies on installers remembering and using the techniques they were trained in.

There is no 'one size fits all' when deciding to install with the power 'ON' or 'OFF' and the decision must be based on a house by house assessment for the following reasons:

- (a) Typically in the North Island there are a significant proportion of houses that have the 'Mains' electrical supply entering underneath the house before joining the Main Switch Board, meaning the power can not be completely isolated;
- (b) Industry experience includes examples where householders have 'bridged' the Main Switch Board between Mains power and the House supply. Therefore turning off at the Main Switch Board may not truly isolate the power to the house; and
- (c) Regardless of the decision to work with power 'ON' or 'OFF', a Registered Electrician must rectify the situation before work continues in the following examples:
 - where there are exposed wires
 - areas where the installation does not allow sufficient (50mm) distance between the staples and the cables (including telephone), or
 - where the cables are 'draped' under joists as illustrated in figure B1.

Amd 1
April '10

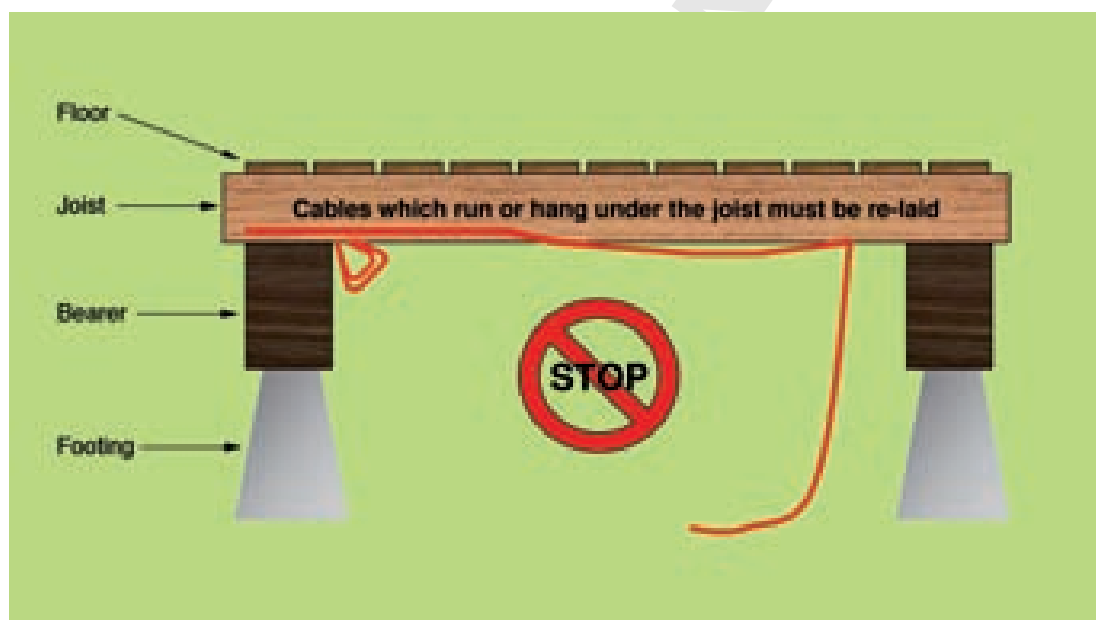

Figure B1 – When not to install underfloor foil insulation

Precautions –The decision to install with the power 'ON' or 'OFF' must be based on the site specific risk assessment and all practicable steps available must be taken to protect the installers and house occupant from electrocution. The power 'ON' or 'OFF' options set out in tables B1 and B2 were developed in March 2006, by a focus group from the retrofit insulation industry. The options were used in a broader consultation exercise with the industry, and regulatory agencies, resulting in the following practical steps that can be taken during underfloor installation.

Table B1 – Installing underfloor insulation with power on

POWER 'ON' OPTION			
#	STEPS	HAZARDS	FURTHER PRECAUTIONS
1	Provide good sources of light to carry out the installation.	Supplies to the lights may become damaged during installation and electrocute installers.	Place Residual Current Devices (RCD) 'in-line' to protect the installers.
2	Identify all wires and services under the house and inspect them for damage.	Damaged cable sheaths will expose the installer to an unacceptably high risk of electrocution.	If damaged sheaths are identified; stop the installation, inform the householder that they will need to arrange for a Registered Electrician to rectify the fault before work can commence.
3	Carry out the installation using the 50mm isolation rule or protect all electrical cables using a conduit or other suitable method to 'box' them in.	Cables/services will remain hidden when the installation has been completed. Isolation rule (50mm rule) relies on skilled installers following it and having been given a high standard of training.	Identify and tag all cables/services with the appropriate hazard warning symbol. Using rubber faced gloves and tools will reduce the likelihood of electrocution. However, unless they are designed to isolate the user from electricity their effectiveness can not be relied on.
If a cable is penetrated during the installation a Registered Electrician will be required to rectify the fault before work can continue.			

Table B2 – Installing underfloor insulation with power off

POWER 'OFF' OPTION			
#	STEPS	HAZARDS	FURTHER PRECAUTIONS
1	Inform householder power will be turned off for a given period of time.	Goods stored in householder's fridge/freezer may spoil. Washers & Dryers will need to complete their programmed cycle.	Ensure householder is informed of this prior to the day of installation.
2	Identify if mains power runs under the house before entering the Main Switch Board or has been 'bridged'.	If mains power runs under the house it is not practical to disconnect the house from the supply grid.	For the portion of wiring that can not be turned off follow appropriate isolation rule for 'Power On'.
3	Switch off power at the Main Switch Board and place an electrical isolation tag in place.	Householder does not understand the importance of the isolation tag.	Show them the tag as you fit it and explain that they must not tamper with it or turn the power back on.
4	Check ring circuits to ensure power is off.	Electrical installation may be old and designed on a series of 'spikes' running from the fuse-box.	Double check wiring when entering the underfloor cavity with a electrical proximity meter.

5	Ensure there is an adequate supply of light sources (torches or external generator).	Without good light the installers may be exposed to sharp objects, moulds and stagnant water which may contain Leptospirosis etc.	Don't forget the installers that may be working in the roof-space at the same time. They run the risk of falling through the ceiling. Provide spare torch batteries.
6	Identify location and condition of all wires and services during the installation, inspecting them for damage.	Power Off is temporary and will be switched back on when the installation is completed. Future tradesmen will be placed at risk of electrocution if they are not visually informed of the location of hidden wires and services.	Tag all wires and services during the installation with the appropriate hazard warning symbol. If wires are found to have a damaged sheath – stop the installation. A Registered Electrician will be needed to rectify fault before proceeding.
7	Complete the installation.	Wires may be stapled through during the installation.	–

B8.2 Biological and chemical

Hazard description – Working in residential sites may involve exposure to chemical and biological hazards. The work area for underfloor insulations may have been used as a ‘dumping ground’ for building products which may include containers containing unknown hazardous chemicals. Biological hazards may arise from used needles (which present a significant hazard of blood-borne viruses), broken waste pipes, and animal faeces which can carry many diseases.

Amd 1
April '10

Precautions – Provide adequate lighting during the pre installation inspection to identify; old containers which (if safe to do so), must be removed and disposed of through the local council; needle/syringes which will have to be removed in a suitable sharp-proof container; broken or leaking waste pipes which must be rectified and all contamination removed; faeces which must be bagged and disposed of. In all cases the responsibility for ensuring the work area is clean rests with the occupant or landlord of the property. If the installer agrees to remove these items a thorough assessment of the specific hazards must be undertaken to determine the suitable precautions necessary to secure their own continued safety.

B8.3 Dusts and moulds

Hazard description – Underfloor installations are likely to be in areas where the surrounding ground has been damp for a prolonged period of time. In New Zealand’s temperate climate this can provide the ideal conditions to support the growth of moulds and fungi. When disturbed the resultant dust can be more of a hazard than simple nuisance dust and may lead to the potential for respiratory diseases and chest infections.

Precautions – The conditions underfloor vary from house to house. Some may be damp, while others may be covered in sand. The most important factor therefore is good lighting to assist the installers in making a thorough visual inspection before they commence work. Site conditions may warrant the use of a dust mask, while others may warrant the installation of a full moisture barrier (polythene membrane) prior to the installation of underfloor insulation.

Amd 1
April '10

B8.4 Sharp objects

Hazard description – The installer must be aware of the increased risk of contracting tetanus through cuts or punctures received during underfloor installations. Tetanus is a disease carried in the gut of some animals. Through animal urine and faeces tetanus is easily transferred to sharp objects (nails, glass, tiles) that can introduce tetanus to the installer if they are cut.

Precautions – If an installer receives a cut or puncture they should seek medical advice regarding appropriate inoculation. It is recommended that all installers have their tetanus immunisations up to date.

B8.5 Leptospirosis

Hazard description – Hazards presented by vermin vary depending on the particular diseases they may be carrying at the time. The most common hazard, present in the urine of vermin (possums and rats) and other infected animals (cows and sheep), is known as Leptospirosis and can remain 'live' in damp, moist conditions for several weeks. The bacteria can enter the body through cuts and cracks in the skin or through the eyes, nose or mouth resulting in a flu-like disease.

Precautions – It is important to ensure the foundations are dry when carrying out the underfloor insulation and that all cuts and abrasions are covered with waterproof plasters. Personal hygiene is an important control and installers should not touch their eyes or mouth until they have completed the installation and washed their hands.

B8.6 Confined spaces

Hazard description – A 'confined space' occurs when entering an underfloor space which would not enable a person to readily escape in an emergency. This situation can arise from limited 'crawl' spaces under bearers or joist and must be avoided. Gas leaks under the floor can result in an atmosphere that does not support life 'deleterious atmosphere' which is included in the definition of a 'confined space'.

Precautions – If the installer determines that the crawl space is not large enough to comfortably exit (without having to exhale to reduce chest size), then the underfloor insulation should not be undertaken in this area as this will be considered a 'confined space'. Simply 'cap' the insulation off to the floor and record the rationale for this decision on the site specific hazard assessment.

The exterior of the house should be visually inspected to ensure there is some form of ventilation to the underfloor area. If there is no form of underfloor ventilation to the foundations, the atmosphere may be noxious and underfloor insulation should not be undertaken as this may also constitute a confined space. It is likely that the house will have either not been built to the New Zealand Building Code or have been inappropriately modified and should be rectified by a competent person.

Gas has a pungent scent which has been added to it by the suppliers so a leak can be recognised. If there is a smell of gas underfloor, the installer should withdraw until the leak has been identified and rectified by a competent person.

B9 HOT WATER CYLINDER SAFETY PRECAUTIONS

B9.1 Electricity

Hazard description – Sometimes the sheaths protecting electrical supplies to hot water cylinders will have perished over time leaving exposed ‘live’ wires.

Precautions – Switch off the local power supply to the cylinder before inspection or installation of the cylinder wrap and label the switch as ‘out of use’ ‘risk of electrocution’. The condition of the protective sheath to the power supply should be inspected and a registered electrician called to rectify any faults identified before work continues. Fit the wrap and remove the ‘out of use’ label from the local switch and turn on the power supply, testing the foil (if foil-backed wrap has been used) with an electrical proximity meter to ensure the meter confirms that the foil is not electrically ‘live’ – nil result. If the electrical proximity meter returns a positive result, switch off the power and ensure a registered electrician rectifies any faults before the installation is completed.

Amd 1
April '10

B9.2 Hot surfaces

Hazard description – The New Zealand Building Code stipulates that hot water should not be stored at less than 60°C. Most hot water cylinders are fitted with a non-adjustable thermostat which should control the minimum and maximum temperatures.

Precautions – Check to see if a manual thermostat has been fitted and ensure it reads at 60°C. If it is set higher, it should be reduced to 60°C. If no thermostat is visible then there are no adjustments that can be made by the installer. If accessing the cylinder to fit the wrap requires close contact with the hot surface, the installer should feel the cylinder with the palm of their hand to ensure it doesn't feel uncomfortably hot. If the cylinder feels too hot and adjustment cannot be made, carry out other insulation installations at the residence allowing the cylinder to cool down to a comfortable (test again) temperature. This precaution also applies to insulating hot pipes where contact is unavoidable.

Amd 1
April '10

APPENDIX C – EFFECT OF CLEARANCES ON ROOF *R*-VALUE

(Informative)

- C 1** The holes in insulation required for downlights reduce the effective *R*-value of the roof or ceiling. Tables C1 to C4 provide estimates for the effective loss of insulation material *R*-value when a 200mm or 50mm clearance is required.

These are approximations, as the actual reductions depend on the roof construction and insulation material *R*-value and other factors.

The assumptions made are:

- (a) Clearances of 200mm or 50mm from lamp holder side;
- (b) Insulation material *R*-value of 3;
- (c) Lamp holder radius of 50mm;
- (d) *R*-value of uninsulated ceiling or downlight is 0.25.

Any additional losses from air movement through the fitting are not included in the calculations.

A distance of 2.0m between downlight centres is approximately 4 downlights per 10m², and with a 200mm clearance the *R*-value is reduced from *R*-3 to approximately *R*-2, roughly a one third reduction.

**Table C1 – Clearance 200mm –
Approximate reduction in *R*-value from *R*-3.0 by number of downlights per 10m²**

Downlights per 10 m ²	Percentage area insulated	<i>R</i> -value	Percentage reduction in <i>R</i> -value
1	98	2.5	18
2	96	2.1	30
3	94	1.8	39
4	92	1.6	46
5	90	1.4	52
6	88	1.3	56
7	86	1.2	60
8	84	1.1	63
9	82	1.0	66
10	80	0.9	68

Table C2 – Clearance 200mm –
Approximate reduction in *R*-value from *R*-3.0 by distance between the centre of downlights

Distance between downlight centres (m)	Percentage area insulated	<i>R</i> -value	Percentage reduction in <i>R</i> -value
1.0	80	1.0	68
1.5	91	1.5	49
2.0	95	2.0	35
2.5	97	2.2	26
3.0	98	2.4	19
3.5	98	2.6	15
4.0	99	2.6	12

Table C3 – Clearance 50mm –
Approximate reduction in *R*-value from *R*-3.0 by number of downlights per 10m²

Downlights per 10 m ²	Percentage area insulated	<i>R</i> -value	Percentage reduction in <i>R</i> -value
1	100	2.9	3
2	99	2.8	6
3	99	2.7	9
4	99	2.6	12
5	98	2.6	15
6	98	2.5	17
7	98	2.4	19
8	97	2.4	22
9	97	2.3	24
10	97	2.2	26

Table C4 – Clearance 50mm –
Approximate reduction in *R*-value from *R*-3.0 by distance between the centre of downlights

Distance between downlight centres (m)	Percentage area insulated	<i>R</i> -value	Percentage reduction in <i>R</i> -value
1.0	97	2.2	26
1.5	99	2.6	13
2.0	99	2.8	8
2.5	99	2.8	5
3.0	100	2.9	4
3.5	100	2.9	3
4.0	100	2.9	2

APPENDIX D – SUMMARY OF KEY CHANGES IN NZS 4246:2006 AMENDMENT NO. 1

(Informative)

NOTE – This summary does not list unamended clauses, tables, figures or very minor editorial changes. The term 'rewritten' is a more extensive change than 'modified' which includes only small additions or small deletions.

NZS 4246:2006		Amendment No. 1		
Number	Clause/figure/table heading	Number	Clause/figure/table heading	Description of change
–	Referenced documents	–	Referenced documents	Clause modified
–	Foreword	–	Foreword	Clause modified
1.2.2	Exclusions	1.2.2	Exclusions	Additions to the list
1.3.1	General	1.3.1	General	Clause rewritten
1.3.2	Energy efficiency	1.3.2	Energy efficiency	Clause rewritten
1.3.2.1	Selecting levels of insulation	1.3.2.1	Selecting levels of insulation	Clause rewritten
–	–	1.3.5	Risk of fire	New clause
1.4	Interpretation	1.4	Interpretation	Clause modified
1.5	Notes	1.5	Notes and commentary clauses	Heading only
–	–	1.5.1	Notes	Information moved from 1.5
–	–	1.5.2	Commentary clauses	New clause
1.7	Definitions	1.7	Definitions	Number of definitions deleted, added or modified
2	Insulation materials	2	Insulation products	Clause modified
2.1	Loose-fill	2.1	Insulation products included	Original text deleted and replaced with new clause
2.2	Segments and blanket	2.2	Insulation products excluded	Original text deleted and replaced with new clause
2.3	Rigid sheet products	–	–	Clause deleted
2.4	On-ground vapour barriers	–	–	Clause deleted
2.5	Subfloor reflective insulation	–	–	Clause deleted
2.6	Pipe lagging	–	–	Clause deleted
2.7	Hot water cylinder wrap	–	–	Clause deleted
3	Special considerations	3	Special considerations	Additional information added
–	–	3.2	Labelling	New clause
3.2	Insulation compression	3.3	Insulation compression	Change in clause number
3.3	Water damage	3.4	Water damage	Change in clause number Clause rewritten
–	–	3.4.1	–	New clause
3.4	Recessed light fittings	3.5	Recessed light fittings (downlights)	Change in clause number Clause and header rewritten

NZS 4246:2006		Amendment No. 1		
Number	Clause/figure/table heading	Number	Clause/figure/table heading	Description of change
Table 1	Recessed luminaire clearances from thermal insulation	–	–	Table deleted
3.4.1	Clearance	3.5.1	Clearance between downlight and insulation	Change in clause number Clause and header rewritten
3.4.2	Auxiliary equipment	3.5.2	Auxiliary equipment	Change in clause number Clause rewritten
3.5	Recessed spaces (dropped ceilings)	3.6	Recessed spaces (dropped ceilings)	Change in clause number
Figure 1	Recessed light fitting	Figure 1	Recessed light fitting	Figure replaced
3.6	Heating appliance flues	3.7	Heating appliance flues	Change in clause number Clause rewritten
3.7	Electrical cables	3.8	Electrical cables	Change in clause number Clause modified
3.8	Built-in appliances and enclosures containing electrical equipment	3.9	Built-in appliances and enclosures containing electrical equipment	Change in clause number
3.9	Plumbing	3.10	Plumbing	Change in clause number Clause rewritten
3.10	Wall underlay	3.11	Wall underlay	Change in clause number Clause rewritten
3.11	Drained and ventilated cavities	3.12	Drained and ventilated cavities	Change in clause number
3.11.1	Wall systems with a cavity behind the cladding	3.12.1	Wall systems with a cavity behind the cladding	Change in clause number Some text deleted Commentary clause added
3.11.2	Around the perimeter of an attic space under a pitched roof	3.12.2	Around the perimeter of an attic space under a pitched roof	Change in clause number
3.11.3	Beneath a skillion or low slope roof	3.12.3	Beneath a skillion or low slope roof	Change in clause number New information added
–	–	Figure 3(a)	Roof detail for a low slope	New figure
–	–	Figure 3(b)	Skillion roof with metal tile cladding	New figure
–	–	Figure 3(c)	Low pitch roof with metal tiles	New figure
–	–	Figure 3(d)	Profiled metal roof	New figure
–	–	Figure 3(e)	Metal tile roof	New figure
3.12	Access hatches	3.13	Access hatches	Change in clause number Clause rewritten
3.13	Strapping	3.14	Strapping	Change in clause number Some text deleted
–	–	3.15	Roof space ventilation	New clause
–	–	3.16	Unducted fan units	New clause
–	–	3.17	Unducted passive vents	New clause
–	–	3.18	Insulation of cold and hot water pipes in ceiling spaces	New clause
4	Loose-fill	4	Loose-fill	Clause modified
4.1	Walls – unlined	4.1	Walls – unlined	Clause modified

APPENDIX D – (continued)

NZS 4246:2006		Amendment No. 1		
Number	Clause/figure/table heading	Number	Clause/figure/table heading	Description of change
4.2	Pitched roof, flat ceiling	4.2	Pitched roof, flat ceiling	Clause modified
5.1.2	Blanket (installation between ceiling joists/truss chords)	5.1.2	Blanket (installation between ceiling joists/truss chords)	Clause modified
Figure 6	Blanket installed in an unlined skillion roof	–	–	Figure deleted
5.2.1	Segments	5.2.1	Segments	Clause modified
Figure 7	Segments installed in lined roof	Figure 6	Pitched roof – Segments installed in lined ceiling to top plate with continuous blanket	Change in figure number Figure replaced
5.2.2	Blanket	5.2.2	Blanket	Clause rewritten
Figure 8	Blanket laid across joists/truss chords	Figure 7	Truss roof – Segment installed to top plate with full thickness blanket abutted to end of segment between truss	Change in figure number Figure replaced
Figure 9	Blanket torn over the ceiling joist 300mm back from the top plate	Figure 8	Blanket torn over the ceiling joist 300mm back from the top plate	Change in figure number
Figure 10	Example of ‘tucking in’ showing undesirable compression of insulation at edges	Figure 9	Example of ‘tucking in’ showing undesirable compression of insulation at edges	Change in figure number
Figure 11	Segments correctly installed in new wall installation	Figure 10	Segments correctly installed in new wall installation	Change in figure number
Figure 12	Tearing blanket to fit	Figure 11	Tearing blanket to fit	Change in figure number
Figure 13	Stapling blanket	Figure 12	Stapling blanket	Change in figure number
5.3.3	Segments – masonry walls	5.3.3	Segments – masonry walls	Clause modified
5.3.4	Blanket – masonry walls	5.3.4	Blankets – masonry walls	Clause modified
Figure 14	Completed blanket installation in framed walls	Figure 13	Completed blanket installation in framed walls	Change in figure number
5.4.1	Blanket	5.4.1	Blanket	Clause rewritten
Figure 15	Installing underfloor blanket	Figure 14	Installing underfloor blanket	Change in figure number Figure replaced
6	Rigid sheets	6	Rigid and semi-rigid sheets	Clause rewritten
6.1	Fixings	6.1	Fixings	Clause rewritten Commentary added
6.2	Concertina edges	–	–	Clause deleted
6.3	Pipes and plumbing	6.2	Pipes and plumbing	Change in clause number Clause rewritten
6.4	Electrical cables	6.3	Electrical cables	Change in clause number Clause modified
6.5	Cutting rigid sheets	–	–	Clause deleted
6.6	Ceilings – unlined and lined	6.4	Ceiling – unlined and lined	Change in clause number Clause modified
6.7	Walls – unlined	6.5	Walls – unlined	Change in clause number Clause modified
6.8	Underfloor – new and existing	6.6	Underfloor – new and existing	Change in clause number. Clause modified

NZS 4246:2006		Amendment No. 1		
Number	Clause/figure/table heading	Number	Clause/figure/table heading	Description of change
–	–	6.6.1	Rigid floor installation	New clause
–	–	Figure 15	Installation of underfloor rigid floor insulation	New figure
–	–	6.6.2	Semi-rigid floor installation	New clause
–	–	6.6.2.1	Semi-rigid sheets that are friction fitted only	New clause
–	–	Figure 16	Fitting semi-rigid sheets	New figure
7	Subfloor reflective insulation	–	–	Section deleted
7.1	Floors – new	–	–	Clause deleted
Figure 16	Ensuring correct drape of foil using temporary gauge	–	–	Figure deleted
7.2	Floors – new and existing	–	–	Clause deleted
Figure 17	Foil under existing floor (showing strapping)	–	–	Figure deleted
Figure 18	Correct placement of staples through strapping	–	–	Figure deleted
Figure 19	Foil ‘capping’ on pipe	–	–	Figure deleted
Figure 20	Example of use of identifying labels for cables	–	–	Figure deleted
7.2.1	Ventilated cavities	–	–	Clause deleted
Figure 21	Foil installed under the floor with adjacent ventilated cavity	–	–	Figure deleted
8	Hot water cylinders	7	Hot water cylinder wraps	Change in section number
Figure 22	Insulated hot water cylinder	Figure 17	Insulated hot water cylinder	Change in figure number Figure replaced
9	Vapour barriers	8	On-ground vapour barriers	Change in section number Clause requirements from 9.1 moved here. Clause rewritten
9.1	On-ground vapour barriers	–	–	Clause requirements moved to clause 9
Figure 23	Installing an on-ground vapour barrier	Figure 18	Installing an on-ground vapour barrier	Change in figure number Figure replaced
–	–	Figure 19	On-ground vapour barrier	New figure
10	Pipe lagging	9	Pipe insulation	Change in section number Clause modified
10.1	Fitting the lagging	9.1	Fitting the insulation	Change in clause number
10.1.1	Hessian backed wool	9.1.1	Hessian backed wool	Change in clause number
10.1.2	Closed cell tubular foam	9.1.2	Pre-formed pipe insulation	Change in clause number and title
Figure A1	New Zealand climate zones	Figure A1	New Zealand climate zones	Added text
B2.3	Hot water cylinder wraps	B2.3	Hot water cylinder wraps	Clause modified
B3.1.1	General	B3.1.1	General	Information added

APPENDIX D – (continued)

NZS 4246:2006		Amendment No. 1		
Number	Clause/figure/table heading	Number	Clause/figure/table heading	Description of change
B5	Site specific hazard assessment	B5	Site specific hazard assessment	Clause modified
B8.1	Electricity	B8.1	Electricity	Clause modified
Figure B1	Risk factors for electrocution	–	–	Figure deleted
Figure B2	When not to install underfloor foil insulation	Figure B1	When not to install underfloor foil insulation	Change in figure number
Figure B3	Underfloor foil installation applying the 50mm rule	–	–	Figure deleted
Table B2	Installing underfloor insulation with power off	Table B2	Installing underfloor insulation with power off	Table modified
Appendix C	Compensating for the effect of recessed light fittings on insulation <i>R</i> -value	Appendix C	Effect of clearances on roof <i>R</i> -value	Appendix replaced with new information
C1	–	C1	–	Clause rewritten
Table C1	Reduction in insulation thermal resistance due to missing insulation around recessed light fittings assuming a clearance of 100mm	Table C1	Clearance 200mm – Approximate reduction in <i>R</i> -value from <i>R</i> -3.0 by number of downlights per 10m ²	New table
–	–	Table C2	Clearance 200mm – Approximate reduction in <i>R</i> -value from <i>R</i> -3.0 by distance between the centre of downlights	New table
–	–	Table C3	Clearance 50mm – Approximate reduction in <i>R</i> -value from <i>R</i> -3.0 by number of downlights per 10m ²	New table
–	–	Table C4	Clearance 50mm – Approximate reduction in <i>R</i> -value from <i>R</i> -3.0 by distance between the centre of downlights	New table

Copyright

COPYRIGHT

The copyright of this document is the property of the Standards Council. No part of the text may be reproduced by photocopying or by any other means without the prior written approval of the Chief Executive Officer of Standards New Zealand unless the circumstances are covered by Part III of the Copyright Act 1994.

Standards New Zealand will vigorously defend the copyright in this Standard. Every person who breaches Standards New Zealand's copyright may be liable to a fine not exceeding \$50,000 or to imprisonment for a term not to exceed three months. If there has been a flagrant breach of copyright, Standards New Zealand may also seek additional damages from the infringing party, in addition to obtaining injunctive relief and an account of profits.

Published by Standards New Zealand, the trading arm of the Standards Council, Private Bag 2439, Wellington 6140. Telephone: (04) 498 5990, Fax: (04) 498 5994, Website: <http://www.standards.co.nz>.

© 2006 STANDARDS COUNCIL

Approved by the Standards Council on 4 December 2006 to be a New Zealand Standard pursuant to the provisions of section 10 of the Standards Act 1988. Amendment No. 1 approved by the Standards Council on 23 April 2010.

First published: 20 December 2006
Reprinted incorporating Amendment No. 1: 30 April 2010

The following SNZ references relate to this Standard:

Project No. P 4246
Draft for comment No. DZ 4246
Typeset by: Standards New Zealand
Printed by: The Colour Guy



STANDARDS

NEW ZEALAND

PAEREWA AOTEAROA